

# MLX92216/MLX92217

3-wire  $\mu$ Power Low Voltage Hall Effect Latch/Switch/Omnipolar Datasheet

## 1. Features and Benefits

- $\mu$ Power operation
  - 0.9 $\mu$ A at 1.8V/11Hz
  - 1.2 $\mu$ A at 3.3V/11Hz
  - 1.2 $\mu$ A at 1.8V/22Hz
  - 1.6 $\mu$ A at 3.3V/22Hz
- 1 microwatt power consumption with enable pin (200nA at 5V in disabled state)
- Typical sleep current 0.65  $\mu$ A at 1.8V
- Best in class min/max  $I_{DD}$  tolerances for a stable and predictable power budget
- Operating voltage range from 1.6V to 5.5V
- Push-pull or Open Drain output type
- No external components required
- Selectable Sleep time 0.6ms to 800ms
- Ambient temperature from -40°C to 85°C
- Chopper stabilized very sensitive Hall sensor
- Selectable magnetic thresholds and temperature coefficient
- Various magnetic functions: Unipolar, Omnipolar Switch or Latch
- Under-Voltage Reset protection
- Packages, RoHS compliant
  - DFN-4L (LQ) 1.2mm x 1.6mm
  - TSOT-3L (SE) 2.8mm x 2.9mm

## 2. Application Examples

- Consumer electronics (i.e. TWS)
- Battery powered, Handheld devices
- Industrial & medical appliances
- White goods, smart lock & IoT devices
- Proximity sensor, Reed switch replacement, open/close detection
- Energy & Flow metering

## 3. Description

The MLX92216/17 is a monolithic magnetic sensor IC utilizing a Hall Effect sensor technology.

It has an integrated logic for automatic Sleep/Awake sequencing enabling 1 $\mu$ A average current consumption without any action from the user (depending on the selected product). During the Awake state the chip is comparing the applied magnetic field to the predefined magnetic thresholds and updates its output accordingly. By using the EN pin (available on MLX92217), the user can further reduce the current consumption of the chip by disabling the automatic Sleep/Awake logic and the related analog blocks. During Sleep or Disable state the OUT state remains unchanged regardless of the magnetic field. The OUT state will be refreshed during the next Enable/Awake period. The MLX92216/17 can be selected with various functions: magnetic thresholds, magnetic functions and sleep times.

The MLX92216/17 can be used as general replacement of reed switches having the advantage of solid-state reliability. The MLX92216/17 is suitable for battery-powered devices, lid open/close detection, wake-up switches and other low voltage applications where ultra-low current consumption is critical.

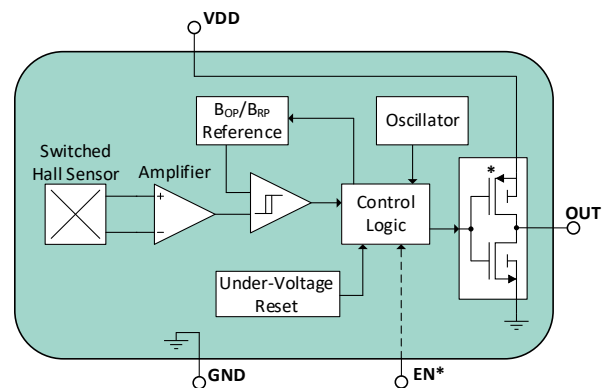

Push-pull output available on some versions  
Enable pin available on MLX92217

*MLX92216/17 functional diagram Push-pull*

# MLX92216/MLX92217

3-wire  $\mu$ Power Low Voltage Hall Effect Latch/Switch/Omnipolar  
Datasheet



## Contents

<b>1. Features and Benefits</b> .....	<b>1</b>
<b>2. Application Examples</b> .....	<b>1</b>
<b>3. Description</b> .....	<b>1</b>
<b>4. Version and ordering Information</b> .....	<b>4</b>
4.1. Production version.....	4
4.2. Engineering versions.....	4
<b>5. Glossary of Terms</b> .....	<b>5</b>
<b>6. Absolute Maximum Ratings</b> .....	<b>5</b>
<b>7. General Electrical Specifications</b> .....	<b>6</b>
<b>8. Version specific parameters</b> .....	<b>7</b>
8.1. Production version.....	7
8.1.1. MLX92216ELQ-AAC-001 / MLX92216ESE-AAC-001.....	7
8.1.2. MLX92216ESE-AAC-003 .....	7
8.1.3. MLX92216ESE-AAC-101 .....	7
8.1.4. MLX92216ESE-AAB-101 .....	8
8.2. Engineering versions.....	9
8.2.1. MLX92216ELQ-AAC-002 / MLX92216ESE-AAC-002.....	9
8.2.2. MLX92216ELQ-AAC-003 .....	9
8.2.3. MLX92216ELQ-AAB-001 / MLX92216ESE-AAB-001.....	9
8.2.4. MLX92216ELQ-AAC-101 .....	10
8.2.5. MLX92216ELQ-AAB-101 .....	10
8.2.6. MLX92216ELQ-AAC-201 / MLX92216ESE-AAC-201.....	10
8.2.7. MLX92217ELQ-AAC-001 .....	11
8.2.8. MLX92217ELQ-AAC-002.....	11
8.2.9. MLX92217ELQ-AAC-101 .....	11
8.2.10. MLX92217ELQ-AAC-102.....	12
8.2.11. MLX92217ELQ-AAB-201.....	12
<b>9. Detailed Description</b> .....	<b>13</b>
9.1. Active magnetic pole definition .....	13
<b>10. Magnetic Behavior</b> .....	<b>14</b>

# MLX92216/MLX92217

3-wire  $\mu$ Power Low Voltage Hall Effect Latch/Switch/Omnipolar  
Datasheet



10.1. Latch Sensor .....	14
10.2. Unipolar Switch Sensor.....	14
10.3. Omnipolar Switch Sensor .....	15
<b>11. Performance graphs .....</b>	<b>16</b>
11.1. $I_{DD\_AVG}$ vs. Temperature .....	16
11.2. $T_{SL}$ vs. Temperature .....	18
11.3. $B_{HYST}$ vs. Temperature .....	20
11.4. $V_{IL}/V_{HI}$ Vs Supply voltage .....	23
<b>12. Typical application schematics.....</b>	<b>24</b>
12.1. Push-Pull Output without Enable (MLX92216) .....	24
12.2. Push-Pull Output with Enable (MLX92217).....	24
12.3. Open Drain Output without Enable (MLX92216).....	25
12.4. Open Drain Output with Enable (MLX92217) .....	25
<b>13. Package Information.....</b>	<b>26</b>
13.1. DFN-4L (LQ Package) .....	26
13.1.1. DFN-4L – Package dimensions .....	26
13.1.2. DFN-4L – Sensitive spot.....	26
13.1.3. DFN-4L – Package marking / Pin definition .....	27
13.2. TSOT-3L (SE package) .....	28
13.2.1. TSOT-3L – Package dimensions.....	28
13.2.2. TSOT-3L – Sensitive spot .....	28
13.2.3. TSOT-3L – Package marking/ Pin definition .....	29
<b>14. IC handling and assembly .....</b>	<b>30</b>
14.1. Storage and handling of plastic encapsulated ICs.....	30
14.2. Assembly of encapsulated ICs.....	30
14.3. Environment and sustainability .....	30
<b>15. Disclaimer.....</b>	<b>31</b>

# MLX92216/MLX92217

3-wire  $\mu$ Power Low Voltage Hall Effect Latch/Switch/Omnipolar  
Datasheet



## 4. Version and ordering Information

### 4.1. Production version

Product code	Enable pin	Output type	Sleep time (ms)	Magnetic function	Magnetic thresholds $B_{OP}/B_{RP}$ (mT)
MLX92216ELQ-AAC-001	No	Push-Pull	90	Unipolar Direct South Switch	4.0/2.5
MLX92216ESE-AAC-001	No	Push-Pull	90	Unipolar Direct South Switch	4.0/2.5
MLX92216ESE-AAC-003	No	Push-Pull	45	Unipolar Direct South Switch	2.3/1.3
MLX92216ESE-AAC-101	No	Push-Pull	45	Omnipolar Direct Switch	$\pm 2.8/\pm 1.8$
MLX92216ESE-AAB-101	No	Open-Drain	90	Omnipolar Direct Switch	$\pm 3.0/\pm 2.0$

### 4.2. Engineering versions

Engineering samples available for prototyping. Contact your local sales representative for industrialization or different product variants (Magnetic thresholds, Sleep time, Average consumption, Output type).

Product code	Enable pin	Output type	Sleep time (ms)	Magnetic function	Magnetic thresholds $B_{OP}/B_{RP}$ (mT)
MLX92216ELQ-AAC-002 <sup>(1)</sup>	No	Push-Pull	90	Unipolar Direct South Switch	4.9/3.2
MLX92216ELQ-AAC-003	No	Push-Pull	45	Unipolar Direct South Switch	2.3/1.3
MLX92216ELQ-AAB-001 <sup>(1)</sup>	No	Open-Drain	4.8	Unipolar direct South switch	3.3/2.3
MLX92216ELQ-AAC-101	No	Push-Pull	45	Omnipolar Direct Switch	$\pm 2.8/\pm 1.8$
MLX92216ELQ-AAB-101	No	Open-Drain	90	Omnipolar direct switch	$\pm 3.0/\pm 2.0$
MLX92216ELQ-AAC-201 <sup>(1)</sup>	No	Push-Pull	1.6	South Latch	1.5/-1.5
MLX92217ELQ-AAC-001	Yes	Push-Pull	1.1	Unipolar direct North switch	-2.7/-1.7
MLX92217ELQ-AAC-002	Yes	Push-Pull	360	Unipolar direct South Switch	3.3/2.3
MLX92217ELQ-AAC-101	Yes	Push-Pull	1.1	Omnipolar direct switch	$\pm 3.6/\pm 2.2$
MLX92217ELQ-AAC-102	Yes	Push-Pull	180	Omnipolar direct switch	$\pm 3.1/\pm 2.1$
MLX92217ELQ-AAB-201	Yes	Open-Drain	0.54	North Latch	-2.3/2.3

<sup>1</sup> Available in TSOT-3L package as well. For example: MLX92216ELQ-AAC-002 will become MLX92216ESE-AAC-002. Only available for variants without Enable functionality/pin

# MLX92216/MLX92217

3-wire  $\mu$ Power Low Voltage Hall Effect Latch/Switch/Omnipolar  
Datasheet

## Legend:

All ordering codes are starting with MLX92216Exx-AAy-zzz-RE or MLX92217Exx-AAy-zzz-RE followed by the ordering code details. MLX92217 has an integrated Enable functionality. MLX92216 is without the Enable function/pin.

Temperature Code:	E = -40°C to 85°C
Package Code:	Exx = LQ: DFN-4L, SE: TSOT-3L
Option Code:	AAy = B: Open-Drain, C: Push-Pull zzz = 0zz: Unipolar switch, 1zz: Omnipolar switch, 2zz: Latch
Packing Form:	RE = Reel
Ordering example:	MLX92216ELQ-AAC-001-RE

## 5. Glossary of Terms

Gauss: G, Tesla: T	Units for the magnetic flux density: 1 mT = 10 G
TC	Temperature Coefficient of the magnetic threshold (in ppm/°C)
B <sub>OP</sub> , B <sub>RP</sub>	Operating/Release magnetic threshold

## 6. Absolute Maximum Ratings

Parameter	Symbol	Value	Unit
Supply voltage <sup>(1)</sup>	V <sub>DD</sub>	6	V
Supply current <sup>(1,2)</sup>	I <sub>DD</sub>	10	mA
Reverse supply voltage <sup>(1)</sup>	V <sub>DDREV</sub>	-0.5	V
Reverse supply current <sup>(1,3)</sup>	I <sub>DDREV</sub>	-10	mA
Open Drain Output voltage <sup>(1)</sup>	V <sub>OUTOD</sub>	6	V
Push-Pull Output voltage <sup>(1)</sup>	V <sub>OUTPP</sub>	V <sub>DD</sub> + 0.5	V
Output current <sup>(1,2)</sup>	I <sub>OUT</sub>	10	mA
Reverse Output voltage <sup>(1)</sup>	V <sub>OUTREV</sub>	-0.5	V
Reverse Output current <sup>(1,2)</sup>	I <sub>OUTREV</sub>	-10	mA
Enable voltage <sup>(1)</sup>	V <sub>EN</sub>	6	V
Enable current <sup>(1,3)</sup>	I <sub>EN</sub>	10	mA
Reverse Enable voltage <sup>(1)</sup>	V <sub>ENREV</sub>	-0.5	V
Reverse Enable current <sup>(1,3)</sup>	I <sub>ENREV</sub>	-10	mA
Maximum junction temperature	T <sub>J</sub>	+125	°C
ESD – HBM <sup>(4)</sup>	-	3.5	kV
ESD – CDM <sup>(5)</sup>	-	500	V

Exceeding the absolute maximum ratings may cause permanent damage. Exposure to absolute maximum-rated conditions for extended periods may affect device reliability.

<sup>1</sup> For maximum 1 hour

<sup>2</sup> Including the current through the protection device

<sup>3</sup> Current through the protection device

<sup>4</sup> Human Body Model according or ANSI/ESDA/JEDEC JS-001 standard

<sup>5</sup> Charged Device Model according or ANSI/ESDA/JEDEC JS-002 standard

# MLX92216/MLX92217

3-wire  $\mu$ Power Low Voltage Hall Effect Latch/Switch/Omnipolar  
Datashheet



## 7. General Electrical Specifications

Operating conditions  $V_{DD} = 1.6V$  to  $5.5V$ ,  $T_A = -40^{\circ}C$  to  $85^{\circ}C$  (unless otherwise specified)

Electrical Parameter	Symbol	Condition	Min	Typ <sup>(1)</sup>	Max	Unit
Under Voltage Reset threshold	$V_{UVR}$		–	1.2	1.4	V
Disable Supply Current	$I_{DD\_DIS}$	EN=0, $V_{DD}=3.3V$	–	0.2	–	$\mu A$
Awake Supply Current	$I_{DD\_AWK}$	$V_{DD} = 1.8V$	–	1.7	2.1	mA
		$V_{DD} = 3.3V$	–	2.4	2.9	mA
		$V_{DD} = 5.0V$	–	3.2	3.9	mA
Sleep Supply Current	$I_{DD\_SLP}$	$V_{DD} = 1.8V$	–	0.65	1.3	$\mu A$
		$V_{DD} = 3.3V$	–	0.85	1.7	$\mu A$
		$V_{DD} = 5.0V$	–	1.3	2.5	$\mu A$
Output-High voltage <sup>(3)</sup>	$V_{OH}$	$I_{OUT} = -1mA$	$V_{DD} - 0.4$	$V_{DD} - 0.13$	–	V
Output-Low voltage	$V_{OL}$	$I_{OUT} = 1mA$	–	0.1	0.3	V
Output turned-on resistance - NMOS	$R_{ON\_NMOS}$	$I_{OUT} = 1mA$	–	100	300	$\Omega$
Output turned-on resistance - PMOS <sup>(3)</sup>	$R_{ON\_PMOS}$	$I_{OUT} = -1mA$	–	130	400	$\Omega$
Open drain output leakage	$I_{OFF}$	$V_{OUT} = 5.5V$	–	–	1	$\mu A$
Output rise time <sup>(2,3)</sup>	$t_R$	$C_{LOAD} = 50pF$	–	0.1	–	$\mu s$
Output fall time <sup>(2)</sup>	$t_F$	$C_{LOAD} = 50pF$	–	0.1	–	$\mu s$
Enable leakage	$I_{EN\_OFF}$	$V_{DD} = 5.5V$			1	$\mu A$
Enable input Low voltage <sup>(4,7)</sup>	$V_{IL}$	$V_{DD} = 3.3V$	0.6	1.0	–	V
Enable input High voltage <sup>(4,7)</sup>	$V_{IH}$	$V_{DD} = 3.3V$	–	1.2	1.6	V
Enable High pulse duration <sup>(4)</sup>	$t_{IH}$	$V_{DD}=3.3V$ EN=1.6V	5	–	–	$\mu s$
Enable rising edge to Output refresh time <sup>(4,8)</sup>	$t_{EO}$		–	21	70	$\mu s$
Power-On time <sup>(5,6,8)</sup>	$t_{ON}$	$V_{DD} = 1.6V$ $\Delta V_{DD}/\Delta t \geq 2V/\mu s$	–	35	80	$\mu s$
Power-On state	–	Output state during $t_{ON}$		High		–
Awake time	$t_{AWK}$		10	14	18	$\mu s$
LQ package thermal resistance	$R_{THJA}$	Single layer PCB, JEDEC standard test boards, still air (LFPM=0)	–	250	–	$^{\circ}C/W$
SE package thermal resistance	$R_{THJA}$	Single layer PCB, JEDEC standard test boards, still air (LFPM=0)	–	300	–	$^{\circ}C/W$

<sup>1</sup> Unless otherwise specified the typical values are defined at  $T_A = +25^{\circ}C$  and  $V_{DD} = 3.3V$

<sup>2</sup> Guaranteed by design and verified by characterization, not production tested

<sup>3</sup> Only valid for versions with Push-Pull output type

<sup>4</sup> Only valid for versions with Enable pin

<sup>5</sup> The Power-On Time represents the time from reaching  $V_{DD} = 1.6V$  to the first refresh of output state, with EN pin tied to VDD or held at high state during the Power-On.

<sup>6</sup> Power-On Slew Rate is not critical for the proper device start-up.

<sup>7</sup> Detailed graph over supply voltage can be found in section 11.4

<sup>8</sup> For omnipolar devices and MLX92217ELQ-AAC-001 one sleep time period has to be added on top of the  $t_{ON}/t_{EO}$ .

# MLX92216/MLX92217

3-wire  $\mu$ Power Low Voltage Hall Effect Latch/Switch/Omnipolar  
Datasheet



## 8. Version specific parameters

### 8.1. Production version

#### 8.1.1. MLX92216ELQ-AAC-001 / MLX92216ESE-AAC-001

Operating conditions  $V_{DD} = 3.3V$ ,  $T_A = -40^\circ C$  to  $85^\circ C$  (unless otherwise specified)

Parameter	Symbol	Condition	Min	Typ <sup>(1)</sup>	Max	Unit
Operating Point	$B_{OP}$		2.9	4.0	5.0	mT
Release Point	$B_{RP}$		1.5	2.5	3.5	mT
Hysteresis	$B_{HYST}$		1.0	1.5	2.2	mT
Active Pole			South			–
Magnetic Function			Direct Unipolar Switch			–
Output Type			Push-Pull			–
Sleep time	$t_{SL}$		65	90	110	ms
Average Supply Current	$I_{DD\_AVG}$	$V_{DD} = 1.8V$	-	0.9	1.5	$\mu A$
		$V_{DD} = 3.3V$	-	1.2	2.0	$\mu A$
		$V_{DD} = 5.0V$	-	1.7	2.8	$\mu A$

#### 8.1.2. MLX92216ESE-AAC-003

Operating conditions  $V_{DD} = 3.3V$ ,  $T_A = -40^\circ C$  to  $85^\circ C$  (unless otherwise specified)

Parameter	Symbol	Condition	Min	Typ <sup>(1)</sup>	Max	Unit
Operating Point	$B_{OP}$		1.3	2.3	3.4	mT
Release Point	$B_{RP}$		0.3	1.3	2.4	mT
Hysteresis	$B_{HYST}$		0.5	1.0	1.5	mT
Active Pole			South			–
Magnetic Function			Direct Unipolar Switch			–
Output Type			Push-Pull			–
Sleep time	$t_{SL}$		32	45	55	ms
Average Supply Current	$I_{DD\_AVG}$	$V_{DD} = 1.8V$	-	1.2	2.0	$\mu A$
		$V_{DD} = 3.3V$	-	1.6	2.6	$\mu A$
		$V_{DD} = 5.0V$	-	2.2	3.6	$\mu A$

#### 8.1.3. MLX92216ESE-AAC-101

Operating conditions  $V_{DD} = 3.3V$ ,  $T_A = -40^\circ C$  to  $85^\circ C$  (unless otherwise specified)

Parameter	Symbol	Condition	Min	Typ <sup>(1)</sup>	Max	Unit
Operating Point South Pole	$B_{OP\_SOUTH}$		1.8	2.8	4.0	mT
Release Point South Pole	$B_{RP\_SOUTH}$		0.8	1.8	3.0	mT
Operating Point North Pole	$B_{OP\_NORTH}$		-4.0	-2.8	-1.8	
Release Point North Pole	$B_{RP\_NORTH}$		-2.9	-1.8	-0.8	
Hysteresis	$B_{HYST}$		0.5	1.0	1.5	mT
Active Pole			South & North			–
Magnetic Function			Direct Omnipolar Switch			–
Output Type			Push-Pull			–
Sleep time <sup>(2)</sup>	$t_{SL}$		32	45	55	ms
Average Supply Current	$I_{DD\_AVG}$	$V_{DD} = 1.8V$	-	1.2	2.0	$\mu A$
		$V_{DD} = 3.3V$	-	1.6	2.6	$\mu A$
		$V_{DD} = 5.0V$	-	2.2	3.6	$\mu A$

<sup>1</sup> Unless otherwise specified the typical values are defined at  $T_A = +25^\circ C$  and  $V_{DD} = 3.3V$

<sup>2</sup> The total update rate for omnipolar devices and MLX92217ELQ-AAC-001 is twice the defined sleep time

# MLX92216/MLX92217

3-wire  $\mu$ Power Low Voltage Hall Effect Latch/Switch/Omnipolar  
Datasheet



## 8.1.4. MLX92216ESE-AAB-101

Operating conditions  $V_{DD} = 3.3V$ ,  $T_A = -40^{\circ}C$  to  $85^{\circ}C$  (unless otherwise specified)

Parameter	Symbol	Condition	Min	Typ <sup>(1)</sup>	Max	Unit
Operating Point South Pole	$B_{OP\_SOUTH}$		2.0	3.0	4.3	mT
Release Point South Pole	$B_{RP\_SOUTH}$		1.0	2.0	3.2	mT
Operating Point North Pole	$B_{OP\_NORTH}$		-4.3	-3.0	-2.0	
Release Point North Pole	$B_{RP\_NORTH}$		-3.2	-2.0	-1.0	
Hysteresis	$B_{HYST}$		0.5	1.0	1.5	mT
Active Pole			South & North			–
Magnetic Function			Direct Omnipolar Switch			–
Output Type			Open-Drain			–
Sleep time <sup>(2)</sup>	$t_{SL}$		65	90	110	ms
Average Supply Current	$I_{DD\_AVG}$	$V_{DD} = 1.8V$	-	0.9	1.5	$\mu A$
		$V_{DD} = 3.3V$	-	1.2	2.0	$\mu A$
		$V_{DD} = 5.0V$	-	1.7	2.8	$\mu A$

<sup>1</sup> Unless otherwise specified the typical values are defined at  $T_A = +25^{\circ}C$  and  $V_{DD} = 3.3V$

<sup>2</sup> The total update rate for omnipolar devices and MLX92217ELQ-AAC-001 is twice the defined sleep time

# MLX92216/MLX92217

3-wire  $\mu$ Power Low Voltage Hall Effect Latch/Switch/Omnipolar  
Datasheet



## 8.2. Engineering versions

Engineering samples available for prototyping. Contact your local sales representative for industrialization or different product variants (Magnetic thresholds, Sleep time, Average consumption, Output type).

### 8.2.1. MLX92216ELQ-AAC-002 / MLX92216ESE-AAC-002

Operating conditions  $V_{DD} = 3.3V$ ,  $T_A = -40^{\circ}C$  to  $85^{\circ}C$  (unless otherwise specified)

Parameter	Symbol	Condition	Min	Typ <sup>(1)</sup>	Max	Unit
Operating Point	$B_{OP}$		3.6	4.9	6.2	mT
Release Point	$B_{RP}$		2.0	3.2	4.4	mT
Hysteresis	$B_{HYST}$		1.1	1.7	2.5	mT
Active Pole			South			–
Magnetic Function			Direct Unipolar Switch			–
Output Type			Push-Pull			–
Sleep time	$t_{SL}$		65	90	110	ms
Average Supply Current	$I_{DD\_AVG}$	$V_{DD} = 1.8V$	-	0.9	1.5	$\mu A$
		$V_{DD} = 3.3V$	-	1.2	2.0	$\mu A$
		$V_{DD} = 5.0V$	-	1.7	2.8	$\mu A$

### 8.2.2. MLX92216ELQ-AAC-003

Operating conditions  $V_{DD} = 3.3V$ ,  $T_A = -40^{\circ}C$  to  $85^{\circ}C$  (unless otherwise specified)

Parameter	Symbol	Condition	Min	Typ <sup>(1)</sup>	Max	Unit
Operating Point	$B_{OP}$		1.3	2.3	3.4	mT
Release Point	$B_{RP}$		0.3	1.3	2.4	mT
Hysteresis	$B_{HYST}$		0.5	1.0	1.5	mT
Active Pole			South			–
Magnetic Function			Direct Unipolar Switch			–
Output Type			Push-Pull			–
Sleep time	$t_{SL}$		32	45	55	ms
Average Supply Current	$I_{DD\_AVG}$	$V_{DD} = 1.8V$	-	1.2	2.0	$\mu A$
		$V_{DD} = 3.3V$	-	1.6	2.6	$\mu A$
		$V_{DD} = 5.0V$	-	2.2	3.6	$\mu A$

### 8.2.3. MLX92216ELQ-AAB-001 / MLX92216ESE-AAB-001

Operating conditions  $V_{DD} = 3.3V$ ,  $T_A = -40^{\circ}C$  to  $85^{\circ}C$  (unless otherwise specified)

Parameter	Symbol	Condition	Min	Typ <sup>(1)</sup>	Max	Unit
Operating Point	$B_{OP}$		2.2	3.3	4.5	mT
Release Point	$B_{RP}$		1.3	2.3	3.4	mT
Hysteresis	$B_{HYST}$		0.5	1.0	1.5	mT
Active Pole			South			–
Magnetic Function			Direct Unipolar Switch			–
Output Type			Open-Drain			–
Sleep time	$t_{SL}$		3.4	4.8	5.9	ms
Average Supply Current	$I_{DD\_AVG}$	$V_{DD} = 1.8V$	-	5.7	8.0	$\mu A$
		$V_{DD} = 3.3V$	-	7.8	11.0	$\mu A$
		$V_{DD} = 5.0V$	-	10.6	17.6	$\mu A$

<sup>1</sup> Unless otherwise specified the typical values are defined at  $T_A = +25^{\circ}C$  and  $V_{DD} = 3.3V$

# MLX92216/MLX92217

3-wire  $\mu$ Power Low Voltage Hall Effect Latch/Switch/Omnipolar  
Datashheet

## 8.2.4. MLX92216ELQ-AAC-101

Operating conditions  $V_{DD} = 3.3V$ ,  $T_A = -40^\circ C$  to  $85^\circ C$  (unless otherwise specified)

Parameter	Symbol	Condition	Min	Typ <sup>(1)</sup>	Max	Unit
Operating Point South Pole	$B_{OP\_SOUTH}$		1.8	2.8	4.0	mT
Release Point South Pole	$B_{RP\_SOUTH}$		0.8	1.8	3.0	mT
Operating Point North Pole	$B_{OP\_NORTH}$		-4.0	-2.8	-1.8	mT
Release Point North Pole	$B_{RP\_NORTH}$		-2.9	-1.8	-0.8	mT
Hysteresis	$B_{HYST}$		0.5	1.0	1.5	mT
Active Pole			South & North			–
Magnetic Function			Direct Omnipolar Switch			–
Output Type			Push-Pull			–
Sleep time <sup>(2)</sup>	$t_{SL}$		32	45	55	ms
Average Supply Current	$I_{DD\_AVG}$	$V_{DD} = 1.8V$	-	1.2	2.0	$\mu A$
		$V_{DD} = 3.3V$	-	1.6	2.6	$\mu A$
		$V_{DD} = 5.0V$	-	2.2	3.6	$\mu A$

## 8.2.5. MLX92216ELQ-AAB-101

Operating conditions  $V_{DD} = 3.3V$ ,  $T_A = -40^\circ C$  to  $85^\circ C$  (unless otherwise specified)

Parameter	Symbol	Condition	Min	Typ <sup>(1)</sup>	Max	Unit
Operating Point South Pole	$B_{OP\_SOUTH}$		2.0	3.0	4.3	mT
Release Point South Pole	$B_{RP\_SOUTH}$		1.0	2.0	3.2	mT
Operating Point North Pole	$B_{OP\_NORTH}$		-4.3	-3.0	-2.0	mT
Release Point North Pole	$B_{RP\_NORTH}$		-3.2	-2.0	-1.0	mT
Hysteresis	$B_{HYST}$		0.5	1.0	1.5	mT
Active Pole			South & North			–
Magnetic Function			Direct Omnipolar Switch			–
Output Type			Open-Drain			–
Sleep time <sup>(2)</sup>	$t_{SL}$		65	90	110	ms
Average Supply Current	$I_{DD\_AVG}$	$V_{DD} = 1.8V$	-	0.9	1.5	$\mu A$
		$V_{DD} = 3.3V$	-	1.2	2.0	$\mu A$
		$V_{DD} = 5.0V$	-	1.7	2.8	$\mu A$

## 8.2.6. MLX92216ELQ-AAC-201 / MLX92216ESE-AAC-201

Operating conditions  $V_{DD} = 3.3V$ ,  $T_A = -40^\circ C$  to  $85^\circ C$  (unless otherwise specified)

Parameter	Symbol	Condition	Min	Typ <sup>(1)</sup>	Max	Unit
Operating Point	$B_{OP}$		0.5	1.5	2.5	mT
Release Point	$B_{RP}$		-2.5	-1.5	-0.5	mT
Hysteresis	$B_{HYST}$		2.1	3.0	4.0	mT
Active Pole			South			–
Magnetic Function			Latch			–
Output Type			Push-Pull			–
Sleep time	$t_{SL}$		1.1	1.6	2	ms
Average Supply Current	$I_{DD\_AVG}$	$V_{DD} = 1.8V$	-	16.0	20.0	$\mu A$
		$V_{DD} = 3.3V$	-	22.0	27.0	$\mu A$
		$V_{DD} = 5.0V$	-	29.0	48.0	$\mu A$

<sup>1</sup> Unless otherwise specified the typical values are defined at  $T_A = +25^\circ C$  and  $V_{DD} = 3.3V$

<sup>2</sup> The total update rate for omnipolar devices and MLX92217ELQ-AAC-001 is twice the defined sleep time

# MLX92216/MLX92217

3-wire  $\mu$ Power Low Voltage Hall Effect Latch/Switch/Omnipolar  
Dataseheet

## 8.2.7. MLX92217ELQ-AAC-001

Operating conditions  $V_{DD} = 3.3V$ ,  $T_A = -40^{\circ}C$  to  $85^{\circ}C$  (unless otherwise specified)

Parameter	Symbol	Condition	Min	Typ <sup>(1)</sup>	Max	Unit
Operating Point	$B_{OP}$		-3.8	-2.7	-1.6	mT
Release Point	$B_{RP}$		-2.8	-1.7	-0.6	mT
Hysteresis	$B_{HYST}$		0.5	1.0	1.5	mT
Active Pole			North			–
Magnetic Function			Direct Unipolar Switch			–
Output Type			Push-Pull			–
Sleep time	$t_{SL}$		0.8	1.1	1.3	ms
Average Supply Current	$I_{DD\_AVG}$	$V_{DD} = 1.8V$	-	23.0	38.0	$\mu A$
		$V_{DD} = 3.3V$	-	32.0	53.0	$\mu A$
		$V_{DD} = 5.0V$	-	42.0	70.0	$\mu A$

## 8.2.8. MLX92217ELQ-AAC-002

Operating conditions  $V_{DD} = 3.3V$ ,  $T_A = -40^{\circ}C$  to  $85^{\circ}C$  (unless otherwise specified)

Parameter	Symbol	Condition	Min	Typ <sup>(1)</sup>	Max	Unit
Operating Point	$B_{OP}$		2.2	3.3	4.5	mT
Release Point	$B_{RP}$		1.3	2.3	3.4	mT
Hysteresis	$B_{HYST}$		0.5	1.0	1.5	mT
Active Pole			South			–
Magnetic Function			Direct Unipolar Switch			–
Output Type			Push-Pull			–
Sleep time	$t_{SL}$		260	360	440	ms
Average Supply Current	$I_{DD\_AVG}$	$V_{DD} = 1.8V$	-	0.75	1.3	$\mu A$
		$V_{DD} = 3.3V$	-	0.95	1.6	$\mu A$
		$V_{DD} = 5.0V$	-	1.5	2.5	$\mu A$

## 8.2.9. MLX92217ELQ-AAC-101

Operating conditions  $V_{DD} = 3.3V$ ,  $T_A = -40^{\circ}C$  to  $85^{\circ}C$  (unless otherwise specified)

Parameter	Symbol	Condition	Min	Typ <sup>(1)</sup>	Max	Unit
Operating Point South Pole	$B_{OP\_SOUTH}$		2.2	3.6	5.0	mT
Release Point South Pole	$B_{RP\_SOUTH}$		1.0	2.2	3.5	mT
Operating Point North Pole	$B_{OP\_NORTH}$		-5.0	-3.6	-2.2	mT
Release Point North Pole	$B_{RP\_NORTH}$		-3.5	-2.2	-1.0	mT
Hysteresis	$B_{HYST}$		0.8	1.4	2.1	mT
Active Pole			South & North			–
Magnetic Function			Direct Omnipolar Switch			–
Output Type			Push-Pull			–
Sleep time <sup>(2)</sup>	$t_{SL}$		0.8	1.1	1.3	ms
Average Supply Current	$I_{DD\_AVG}$	$V_{DD} = 1.8V$	-	23.0	38.0	$\mu A$
		$V_{DD} = 3.3V$	-	32.0	53.0	$\mu A$
		$V_{DD} = 5.0V$	-	42.0	70.0	$\mu A$

<sup>1</sup> Unless otherwise specified the typical values are defined at  $T_A = +25^{\circ}C$  and  $V_{DD} = 3.3V$

<sup>2</sup> The total update rate for omnipolar devices and MLX92217ELQ-AAC-001 is twice the defined sleep time

# MLX92216/MLX92217

3-wire  $\mu$ Power Low Voltage Hall Effect Latch/Switch/Omnipolar  
Datasheet



## 8.2.10. MLX92217ELQ-AAC-102

Operating conditions  $V_{DD} = 3.3V$ ,  $T_A = -40^{\circ}C$  to  $85^{\circ}C$  (unless otherwise specified)

Parameter	Symbol	Condition	Min	Typ <sup>(1)</sup>	Max	Unit
Operating Point South Pole	$B_{OP\_SOUTH}$		2.0	3.1	4.3	mT
Release Point South Pole	$B_{RP\_SOUTH}$		1.0	2.1	3.2	mT
Operating Point North Pole	$B_{OP\_NORTH}$		-4.3	-3.1	-2.0	mT
Release Point North Pole	$B_{RP\_NORTH}$		-3.2	-2.1	-1.0	mT
Hysteresis	$B_{HYST}$		0.5	1.0	1.5	mT
Active Pole			South & North			-
Magnetic Function			Direct Omnipolar Switch			-
Output Type			Push-Pull			-
Sleep time <sup>(2)</sup>	$t_{SL}$		130	180	220	ms
Average Supply Current	$I_{DD\_AVG}$	$V_{DD} = 1.8V$	-	0.8	1.4	$\mu A$
		$V_{DD} = 3.3V$	-	1.05	1.8	$\mu A$
		$V_{DD} = 5.0V$	-	1.6	2.6	$\mu A$

## 8.2.11. MLX92217ELQ-AAB-201

Operating conditions  $V_{DD} = 3.3V$ ,  $T_A = -40^{\circ}C$  to  $85^{\circ}C$  (unless otherwise specified)

Parameter	Symbol	Condition	Min	Typ <sup>(1)</sup>	Max	Unit
Operating Point	$B_{OP}$		-3.7	-2.3	-1.0	mT
Release Point	$B_{RP}$		1.0	2.3	3.7	mT
Hysteresis	$B_{HYST}$		3.7	4.6	6.2	mT
Temperature compensation	TC			-2000		ppm/ $^{\circ}C$
Active Pole			North			-
Magnetic Function			Latch			-
Output Type			Open Drain			-
Sleep time	$t_{SL}$		0.39	0.54	0.66	ms
Average Supply Current	$I_{DD\_AVG}$	$V_{DD} = 1.8V$	-	45.0	56.0	$\mu A$
		$V_{DD} = 3.3V$	-	62.0	77.0	$\mu A$
		$V_{DD} = 5.0V$	-	82.0	136.0	$\mu A$

<sup>1</sup> Unless otherwise specified the typical values are defined at  $T_A = +25^{\circ}C$  and  $V_{DD} = 3.3V$

<sup>2</sup> The total update rate for omnipolar devices and MLX92217ELQ-AAC-001 is twice the defined sleep time

# MLX92216/MLX92217

3-wire  $\mu$ Power Low Voltage Hall Effect Latch/Switch/Omnipolar  
Datasheet

## 9. Detailed Description

### 9.1. Active magnetic pole definition

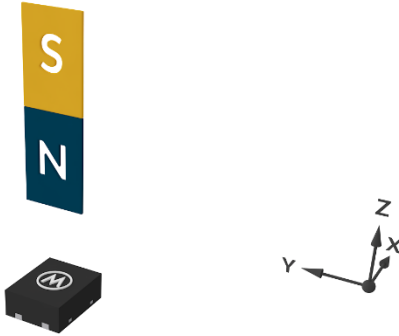

*LQ package – North Pole Active*

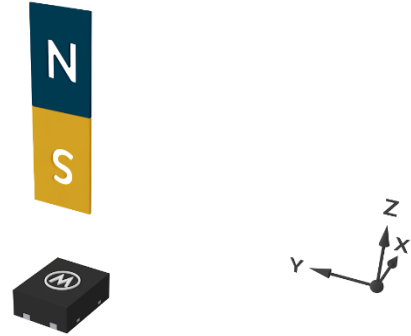

*LQ package – South Pole Active*

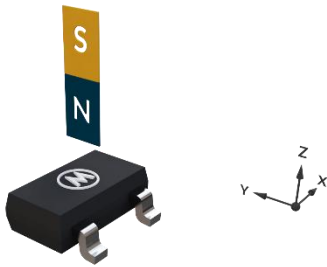

*SE package – North pole active*

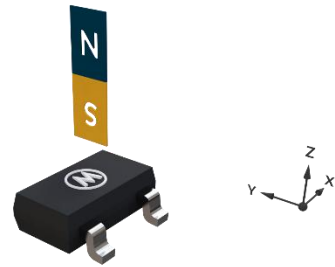

*SE package – South pole active*

# MLX92216/MLX92217

3-wire  $\mu$ Power Low Voltage Hall Effect Latch/Switch/Omnipolar  
Datasheet

## 10. Magnetic Behavior

### 10.1. Latch Sensor

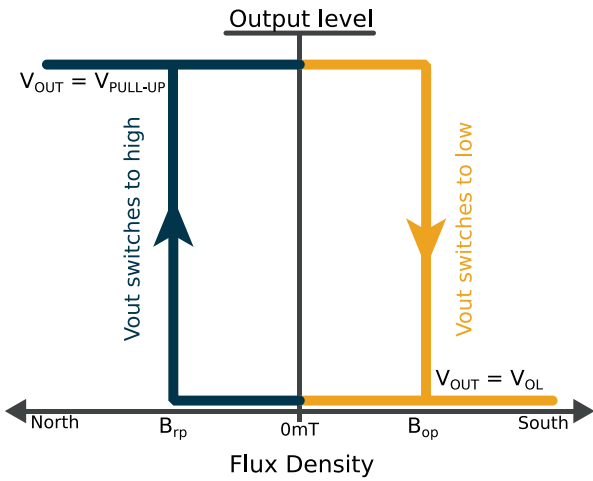

*South Pole Active Latch*

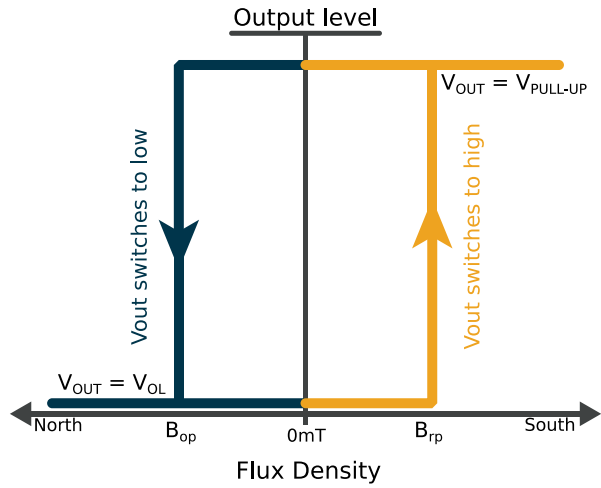

*North Pole Active Latch*

### 10.2. Unipolar Switch Sensor

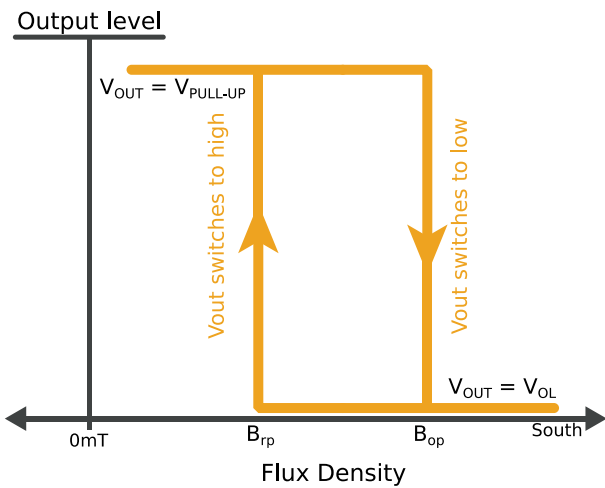

*Direct South Pole Active Switch*

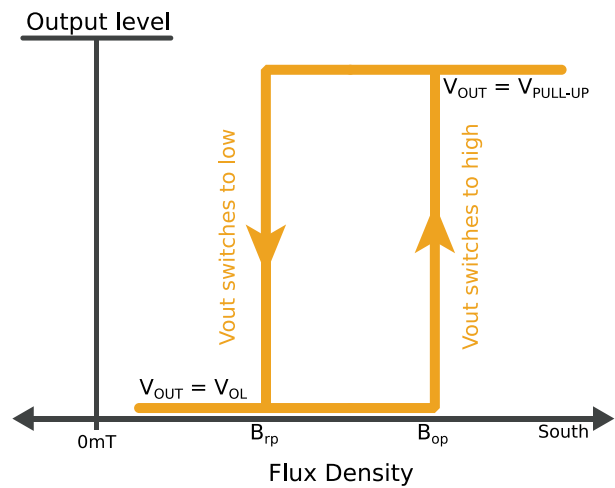

*Inverted South Pole Active Switch*

# MLX92216/MLX92217

3-wire  $\mu$ Power Low Voltage Hall Effect Latch/Switch/Omnipolar  
Datasheet

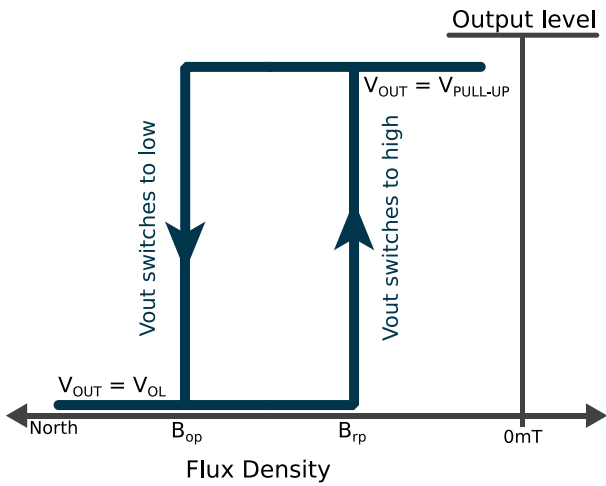

*Direct North Pole Active Switch*

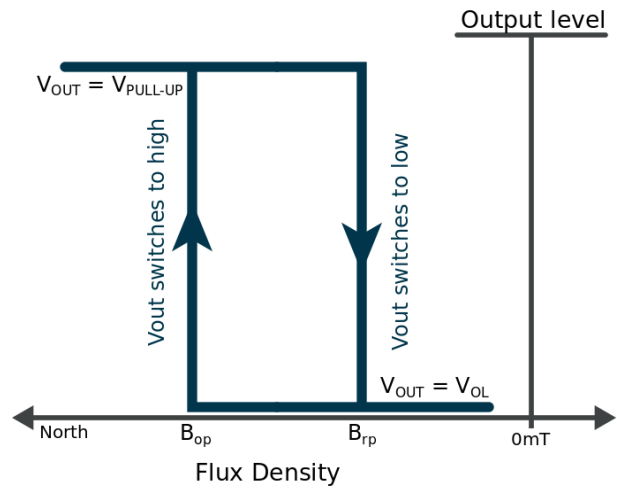

*Inverted North Pole Active Switch*

## 10.3. Omnipolar Switch Sensor

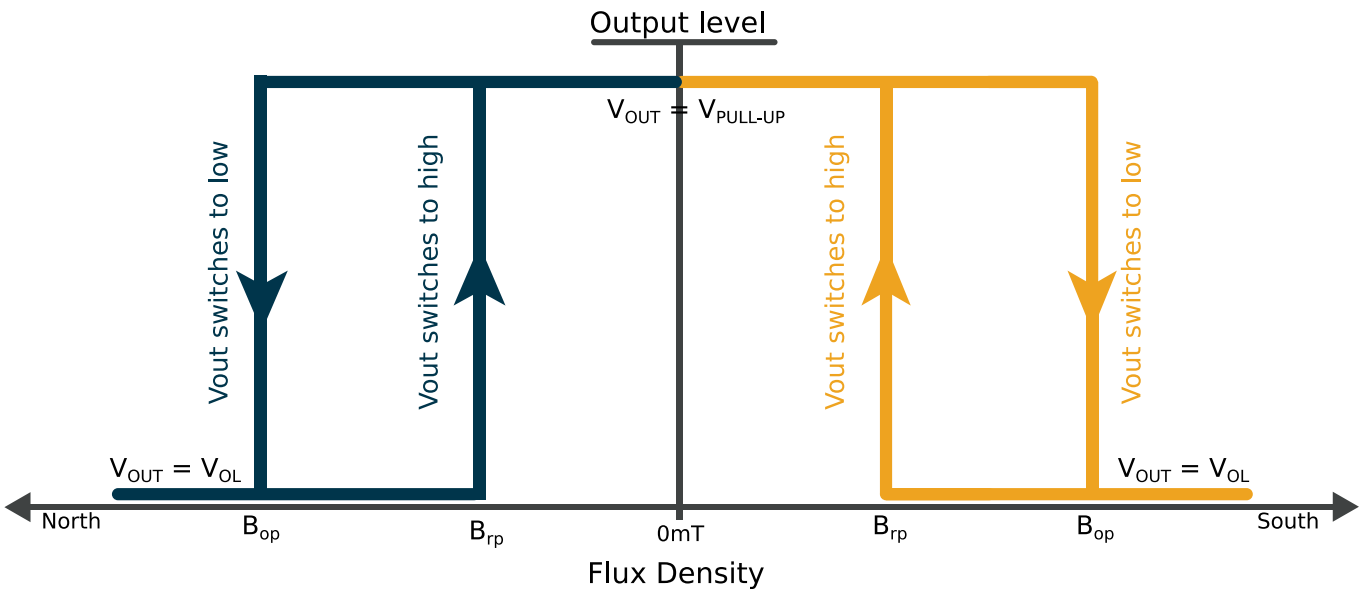

# MLX92216/MLX92217

3-wire  $\mu$ Power Low Voltage Hall Effect Latch/Switch/Omnipolar  
Datasheet



## 11. Performance graphs

### 11.1. $I_{DD\_AVG}$ vs. Temperature

MLX92216ELQ-AAC-001 / MLX92216ESE-AAC-001

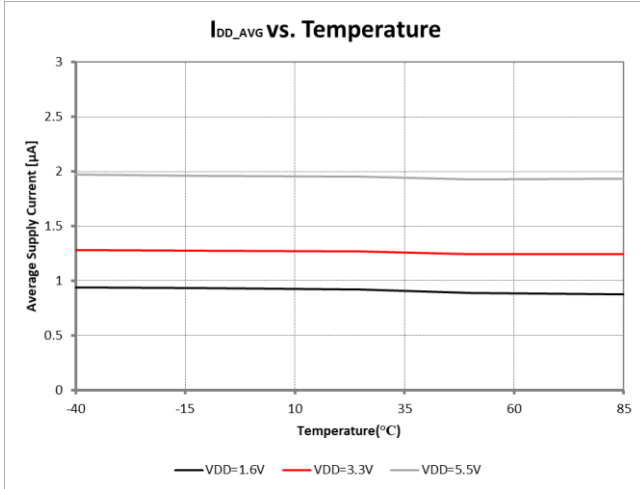

MLX92216ELQ-AAC-002 / MLX92216ESE-AAC-002

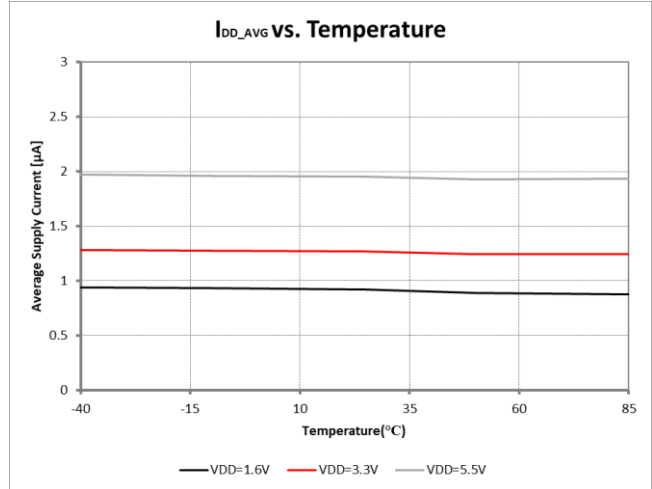

MLX92216ELQ-AAC-003 / MLX92216ESE-AAC-003

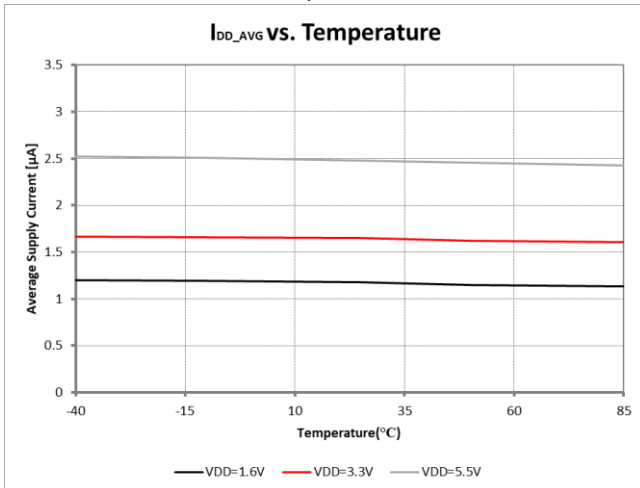

MLX92216ELQ-AAB-001/ MLX92216ESE-AAB-001

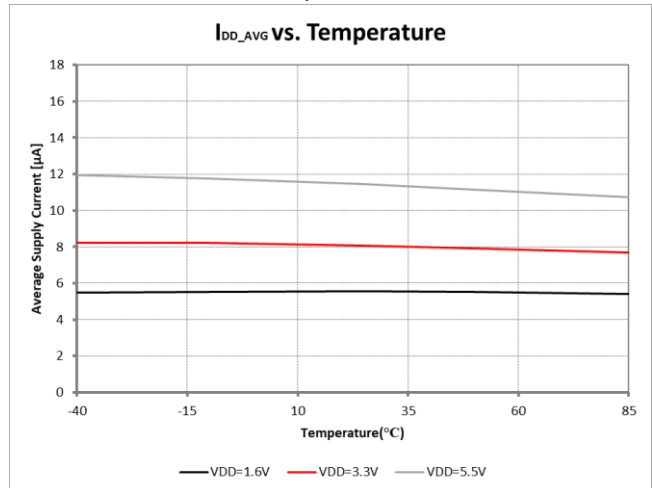

# MLX92216/MLX92217

3-wire  $\mu$ Power Low Voltage Hall Effect Latch/Switch/Omnipolar  
Datasheet



MLX92216ELQ-AAC-101 / MLX92216ESE-AAC-101

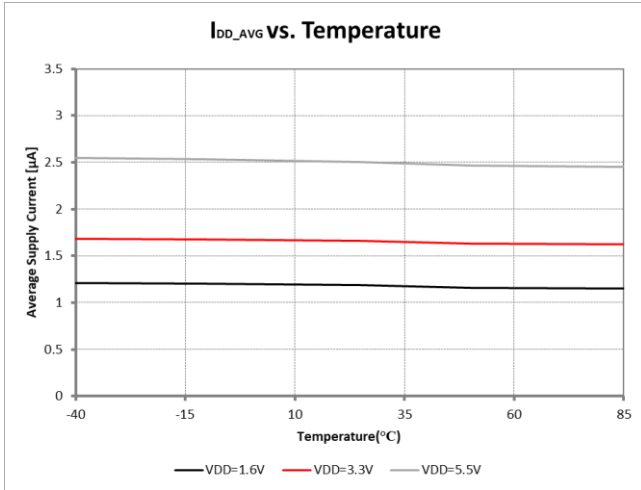

MLX92216ELQ-AAB-101 / MLX92216ESE-AAB-101

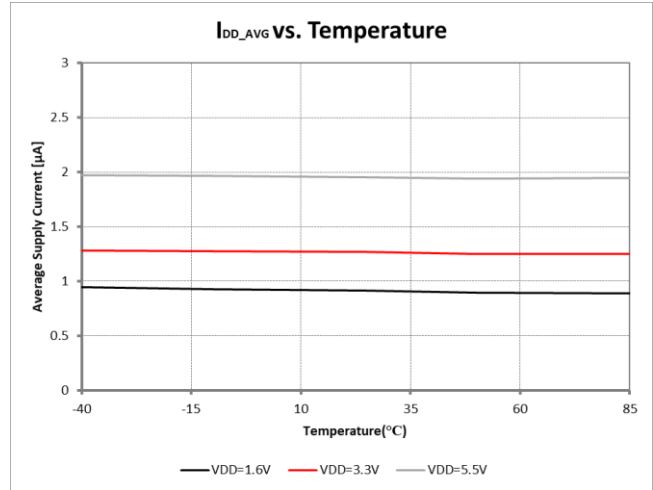

MLX92216ELQ-AAC-201 / MLX92216ESE-AAC-201

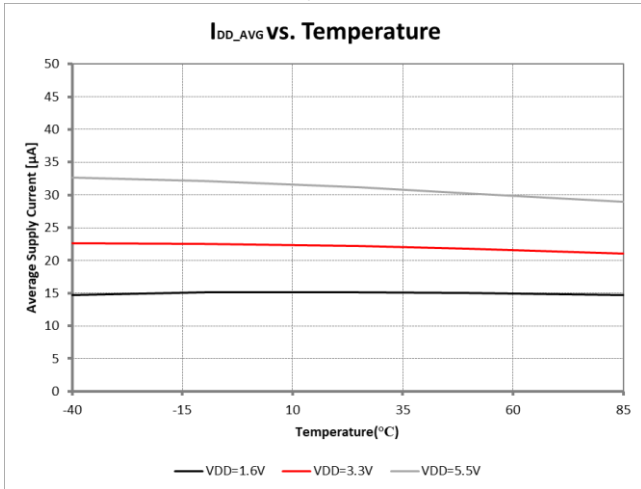

MLX92217ELQ-AAC-001

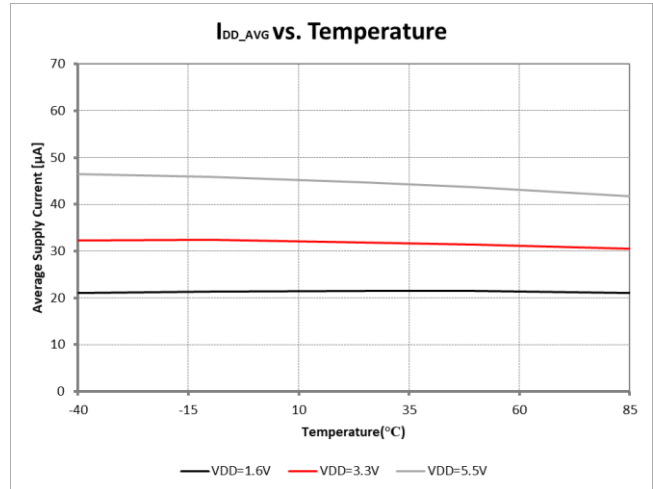

MLX92217ELQ-AAC-002

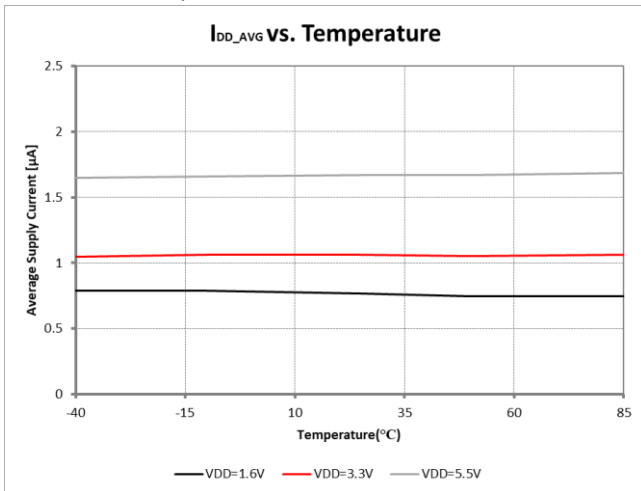

MLX92217ELQ-AAC-101

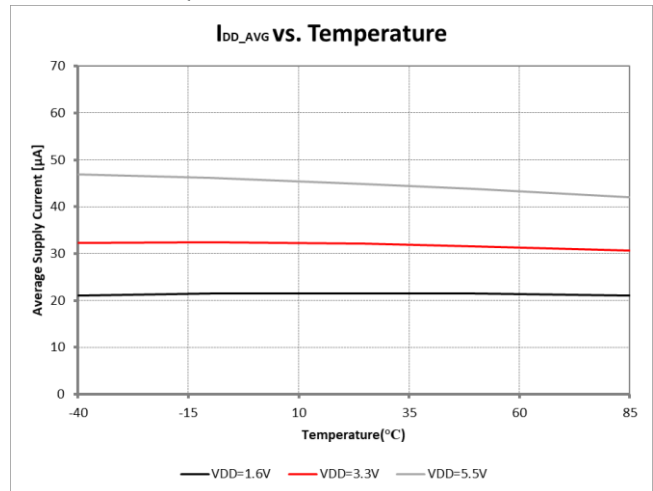

# MLX92216/MLX92217

3-wire  $\mu$ Power Low Voltage Hall Effect Latch/Switch/Omnipolar  
Datasheet

MLX92217ELQ-AAC-102

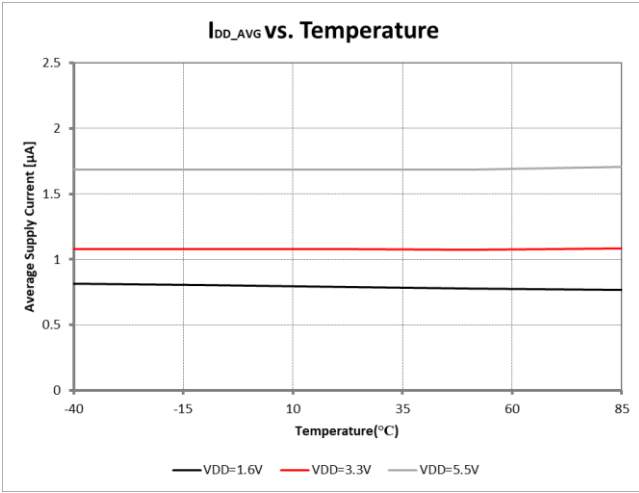

MLX92217ELQ-AAB-201

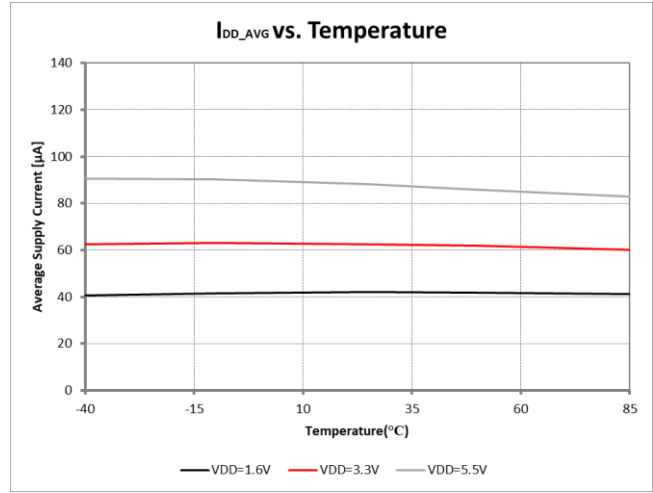

## 11.2. $t_{SL}$ vs. Temperature

MLX92216ELQ-AAC-001 / MLX92216ESE-AAC-001

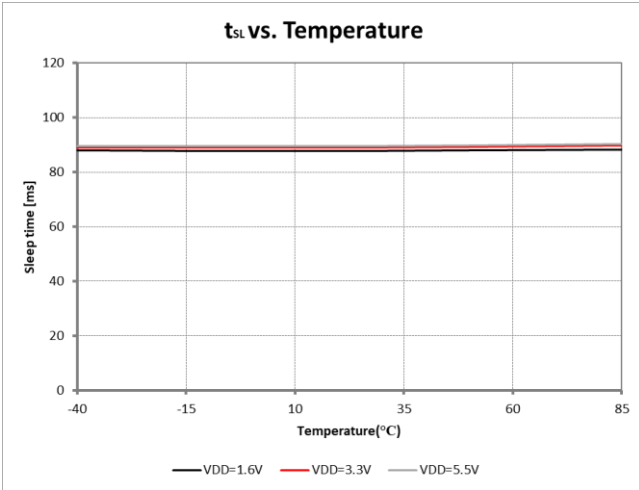

MLX92216ELQ-AAC-002 / MLX92216ESE-AAC-002

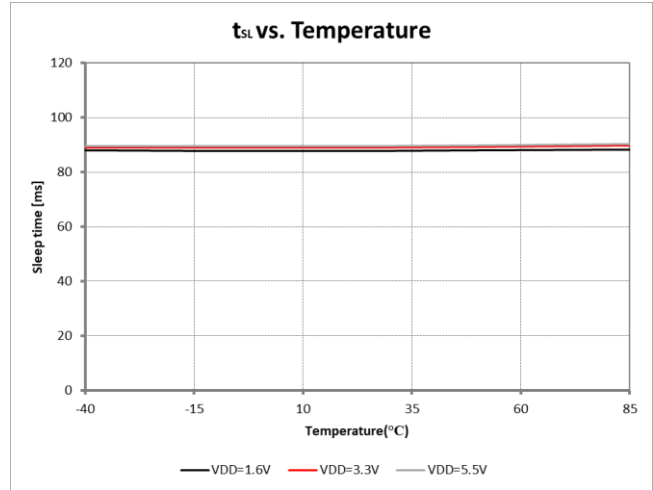

MLX92216ELQ-AAC-003 / MLX92216ESE-AAC-003

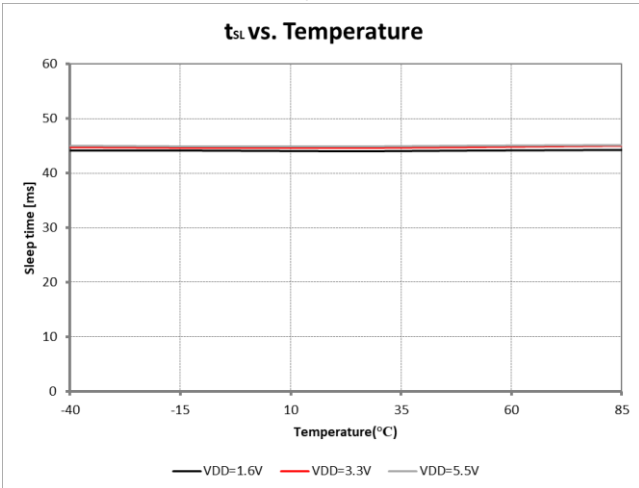

MLX92216ELQ-AAB-001 / MLX92216ESE-AAB-001

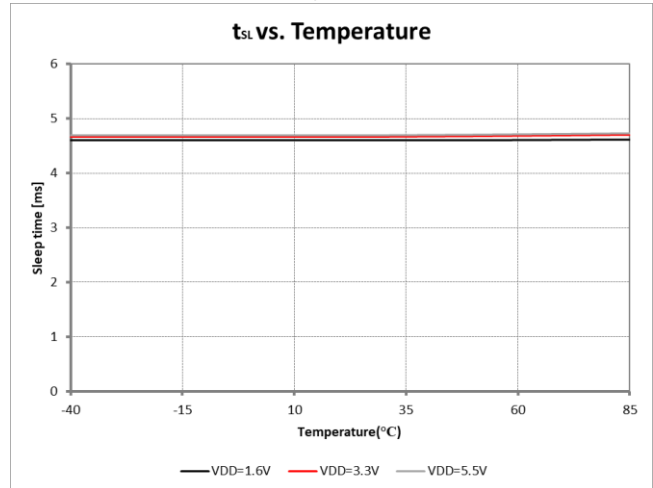

# MLX92216/MLX92217

3-wire  $\mu$ Power Low Voltage Hall Effect Latch/Switch/Omnipolar  
Datasheet



MLX92216ELQ-AAC-101 / MLX92216ESE-AAC-101

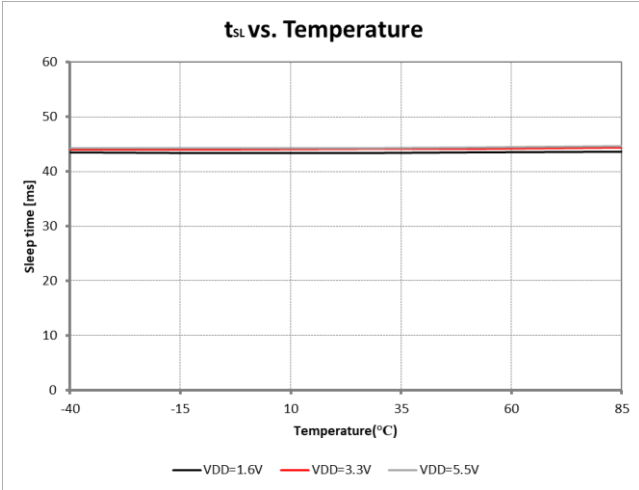

MLX92216ELQ-AAB-101 / MLX92216ESE-AAB-101

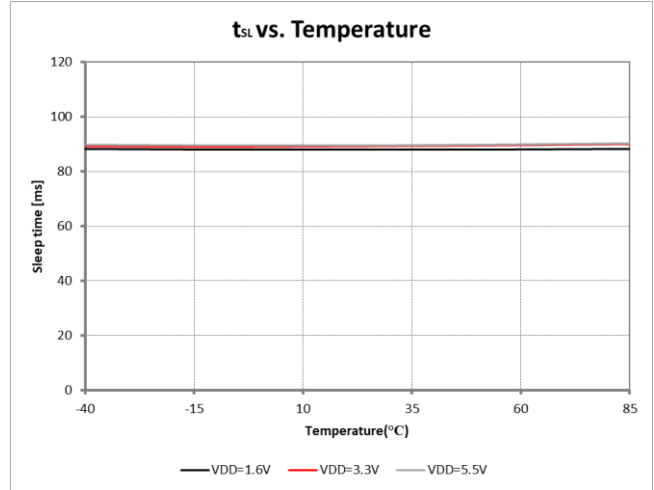

MLX92216ELQ-AAC-201 / MLX92216ESE-AAC-201

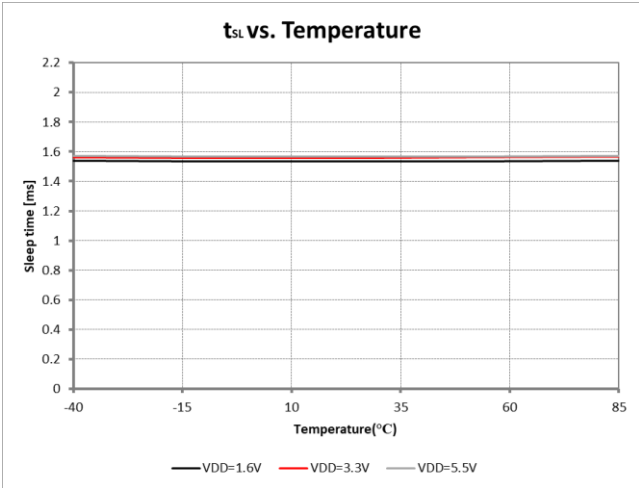

MLX92217ELQ-AAC-001

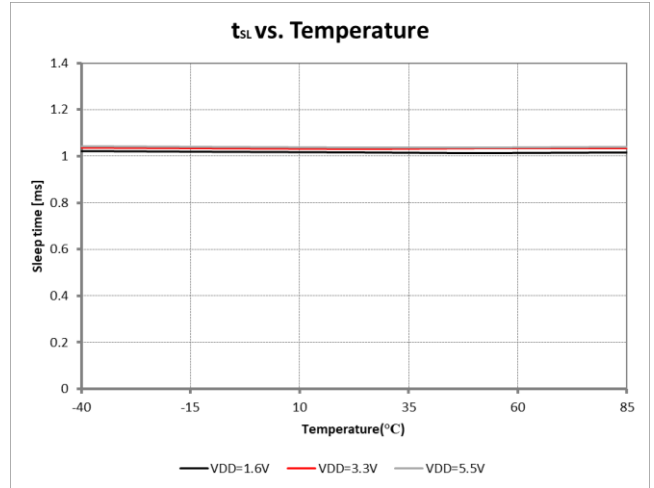

MLX92217ELQ-AAC-002

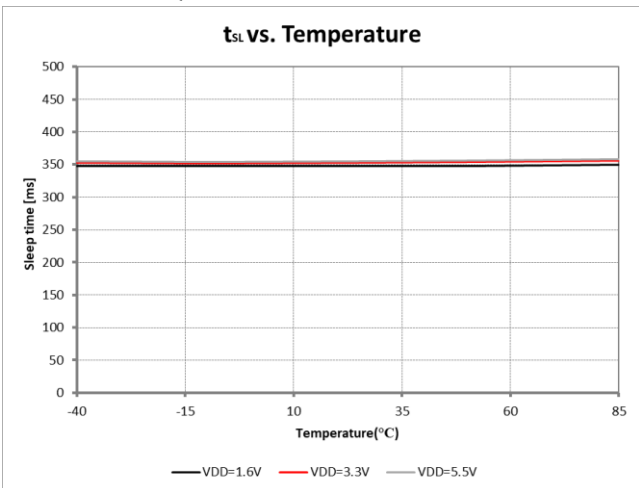

MLX92217ELQ-AAC-101

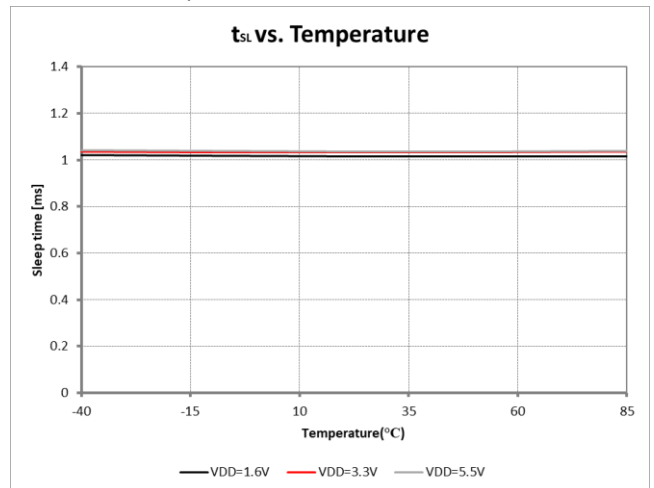

# MLX92216/MLX92217

3-wire  $\mu$ Power Low Voltage Hall Effect Latch/Switch/Omnipolar  
Datasheet

MLX92217ELQ-AAC-102

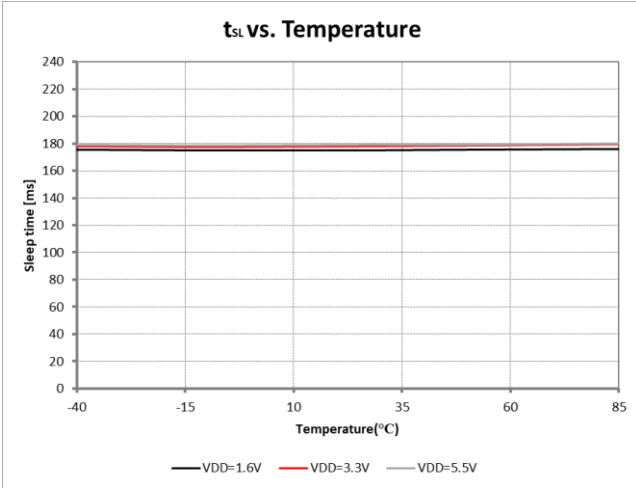

MLX92217ELQ-AAB-201

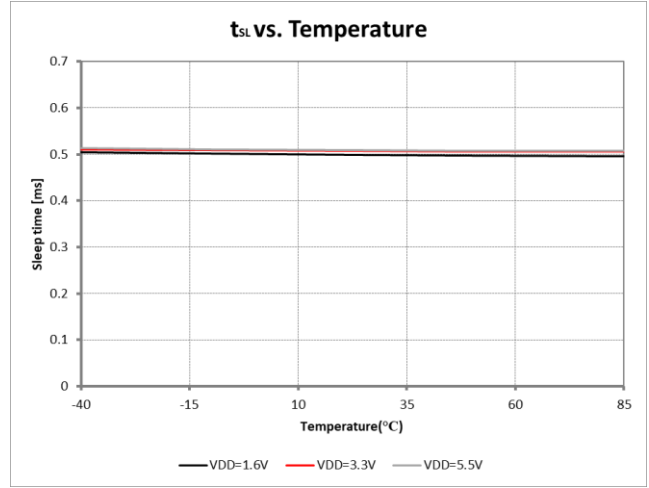

## 11.3. B<sub>HYST</sub> vs. Temperature

MLX92216ELQ-AAC-001 / MLX92216ESE-AAC-001

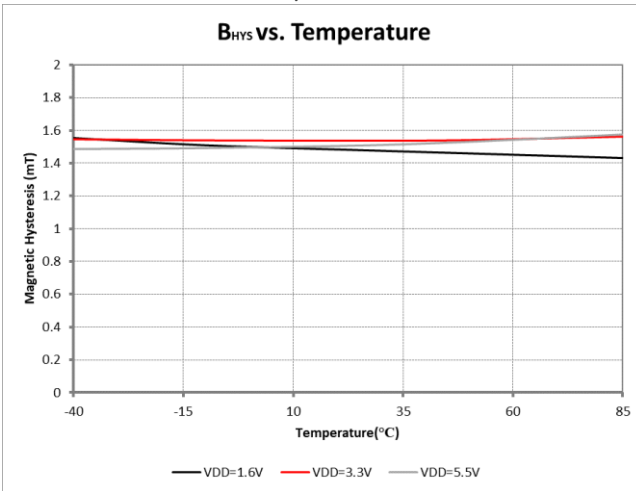

MLX92216ELQ-AAC-002 / MLX92216ESE-AAC-002

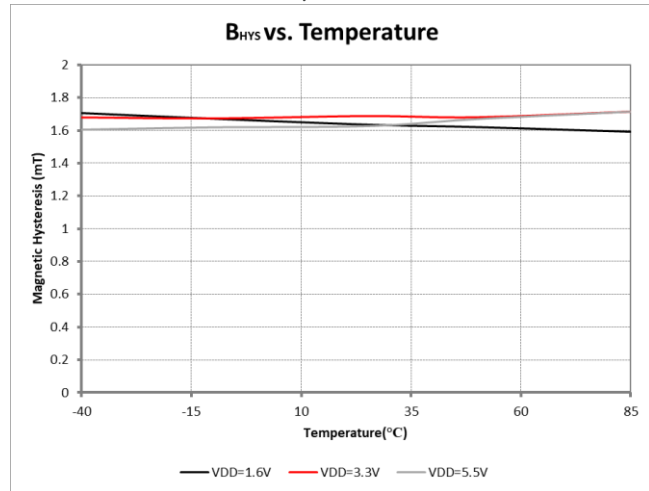

# MLX92216/MLX92217

3-wire  $\mu$ Power Low Voltage Hall Effect Latch/Switch/Omnipolar  
Datasheet



MLX92216ELQ-AAC-003 / MLX92216ESE-AAC-003

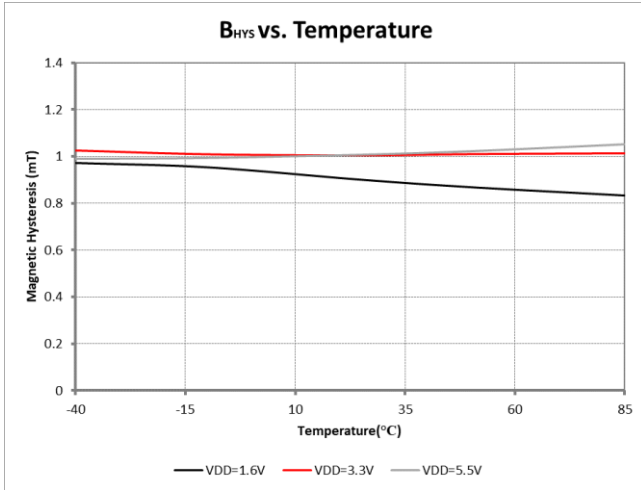

MLX92216ELQ-AAB-001 / MLX92216ESE-AAB-001

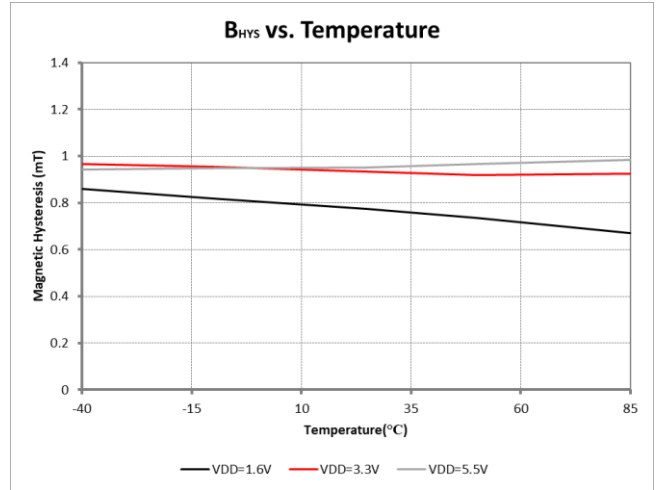

MLX92216ELQ-AAC-101 / MLX92216ESE-AAC-101

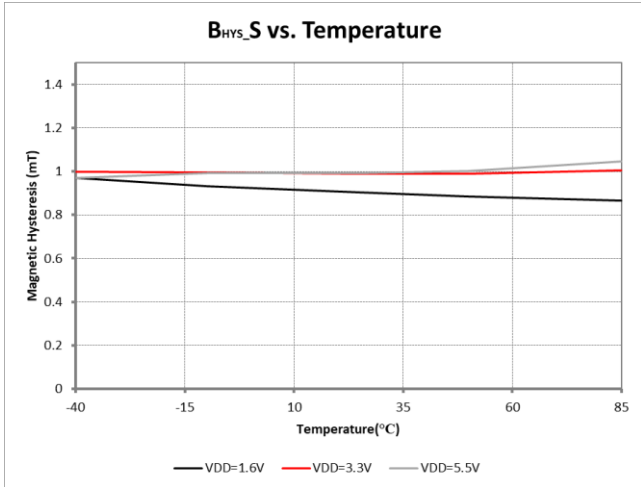

MLX92216ELQ-AAB-101 / MLX92216ESE-AAB-101

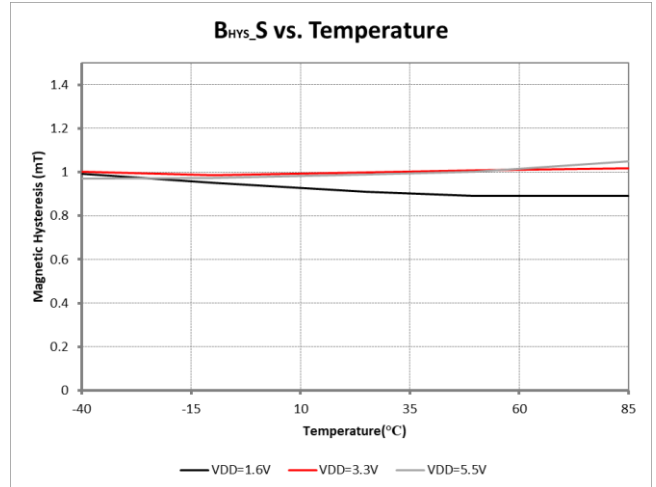

MLX92216ELQ-AAC-201 / MLX92216ESE-AAC-201

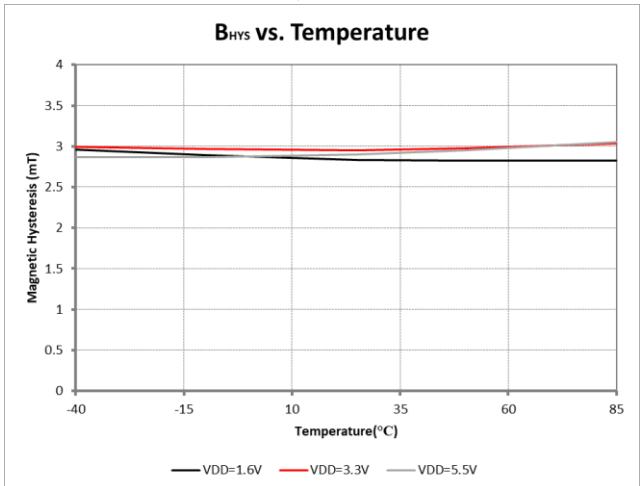

MLX92217ELQ-AAC-001

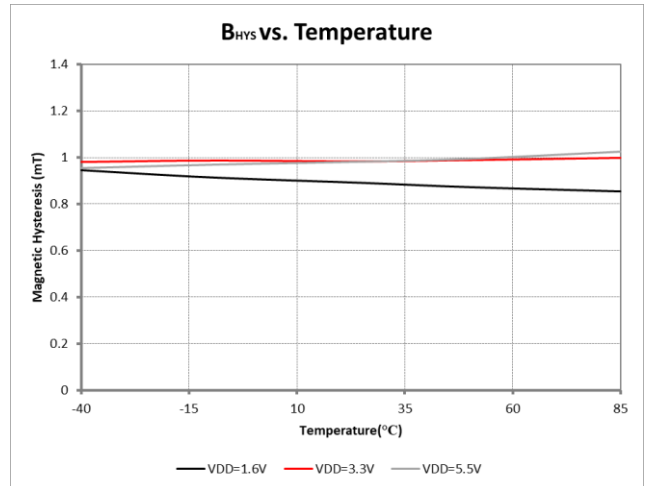

# MLX92216/MLX92217

3-wire  $\mu$ Power Low Voltage Hall Effect Latch/Switch/Omnipolar  
Datasheet

MLX92217ELQ-AAC-002

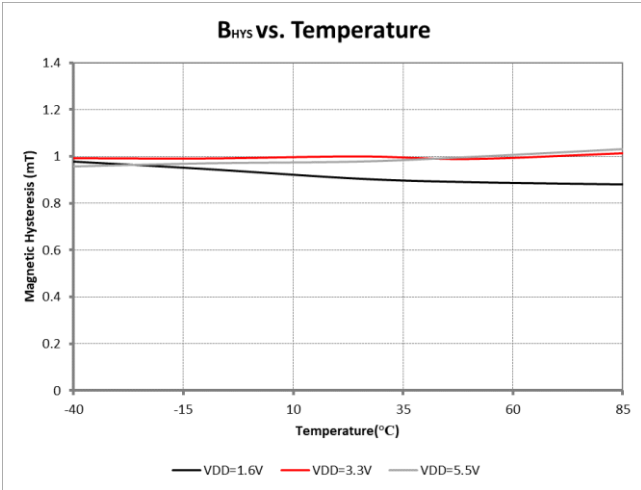

MLX92217ELQ-AAC-101

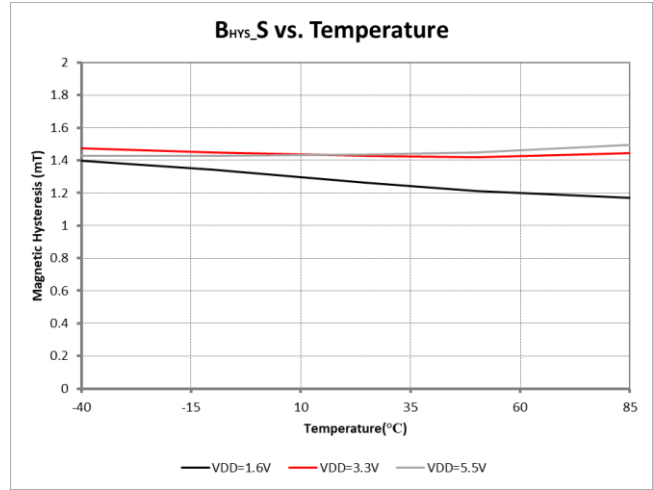

MLX92217ELQ-AAC-102

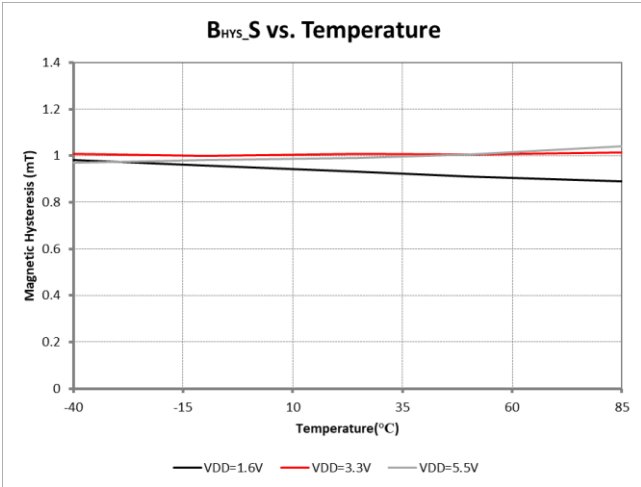

MLX92217ELQ-AAB-201<sup>(1)</sup>

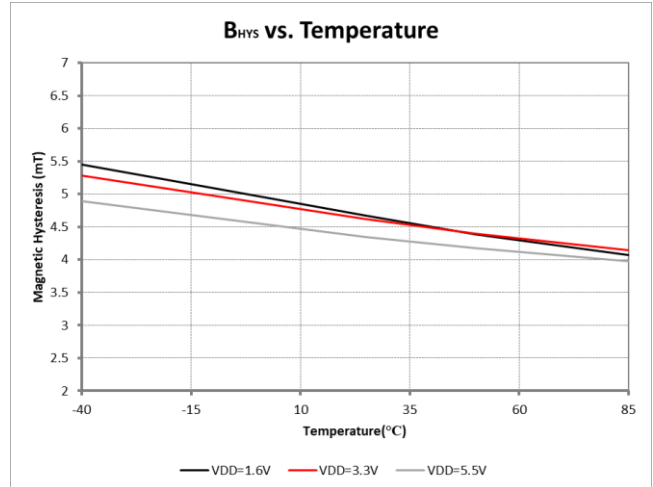

<sup>1</sup> Magnetic thresholds are based on a TC=-2000ppm/deg, therefore the hysteresis is influenced by the ambient temperature.

# MLX92216/MLX92217

3-wire  $\mu$ Power Low Voltage Hall Effect Latch/Switch/Omnipolar  
Datasheet

## 11.4. $V_{IL}/V_{HI}$ Vs Supply voltage

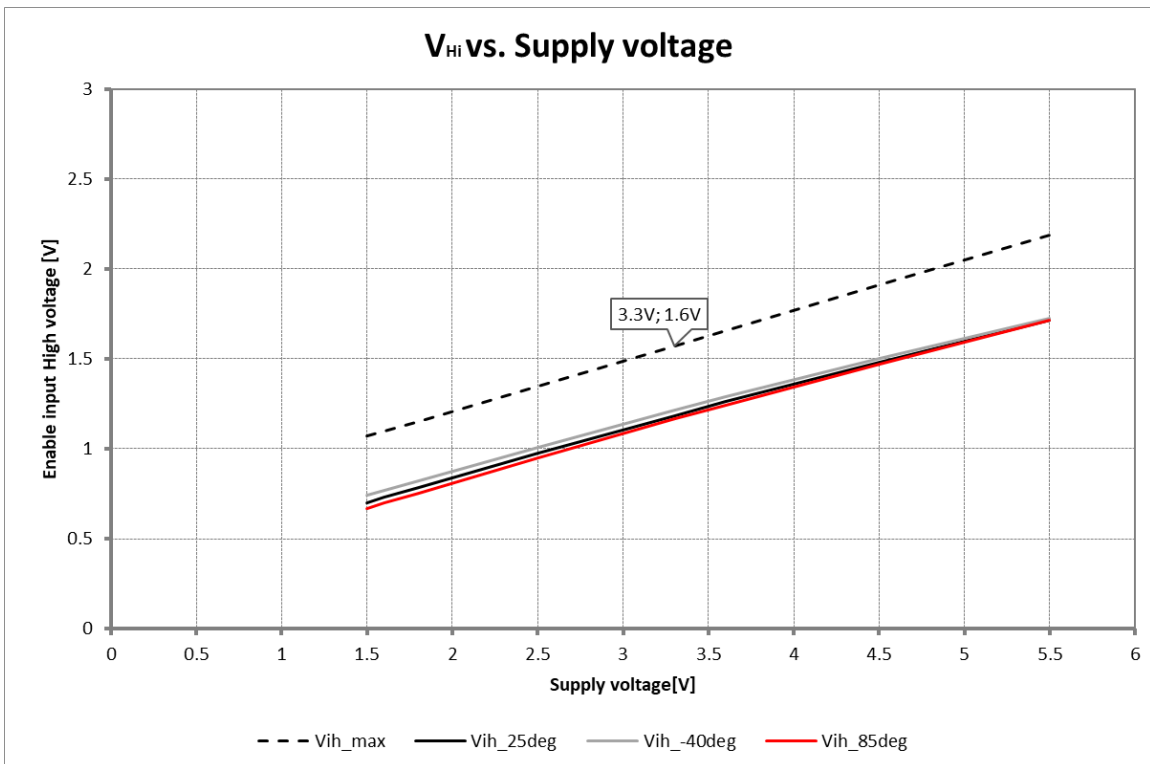
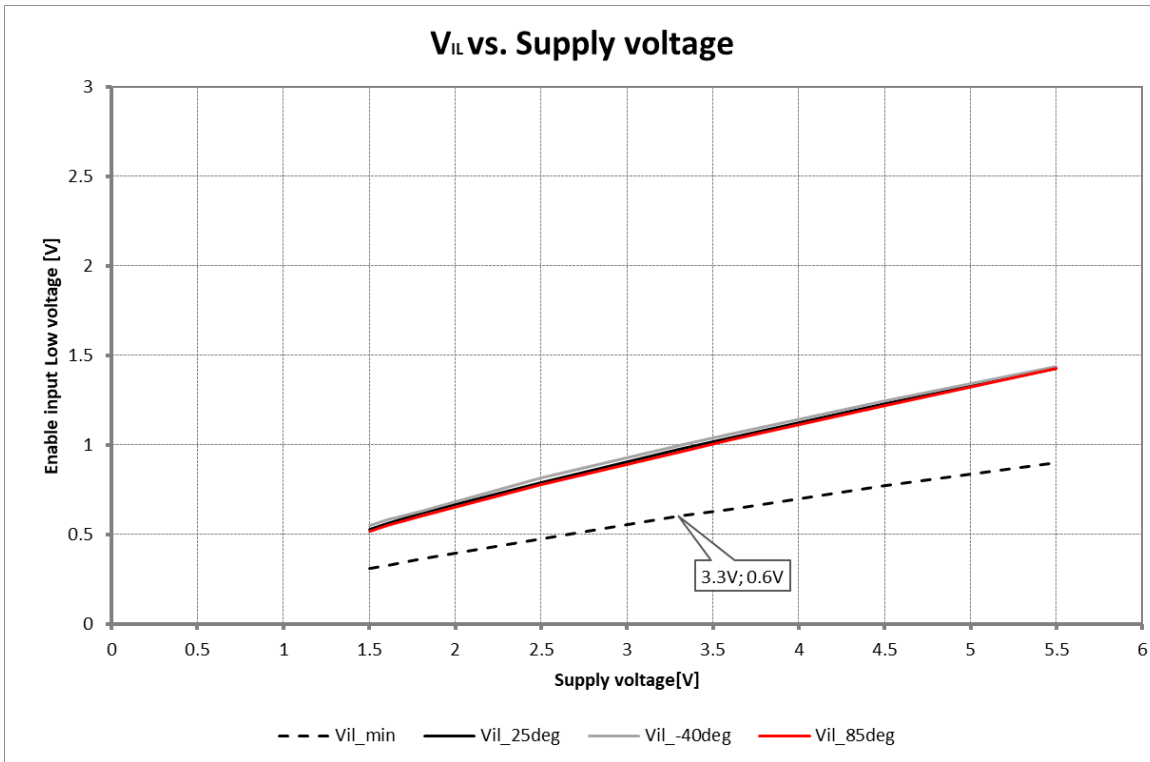

# MLX92216/MLX92217

3-wire  $\mu$ Power Low Voltage Hall Effect Latch/Switch/Omnipolar  
Datasheet

## 12. Typical application schematics

### 12.1. Push-Pull Output without Enable (MLX92216)

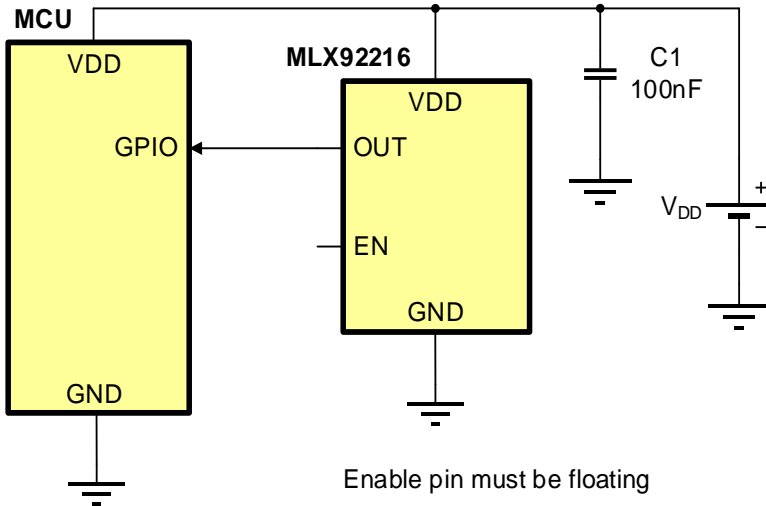

### 12.2. Push-Pull Output with Enable (MLX92217)

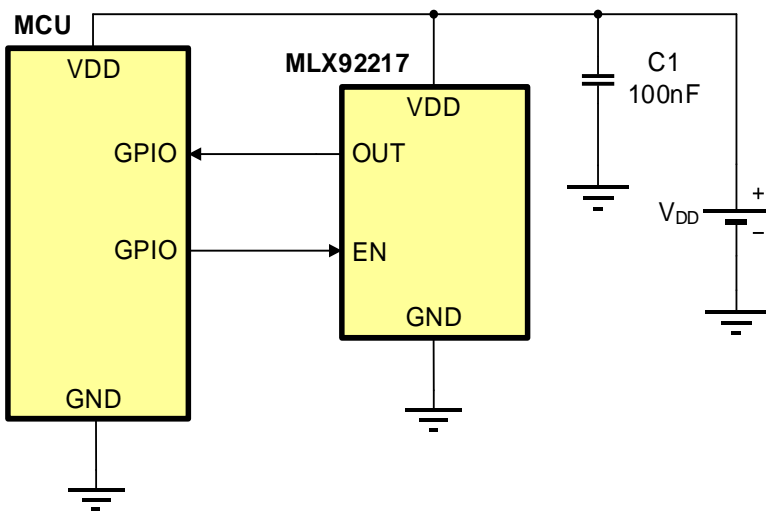

# MLX92216/MLX92217

3-wire  $\mu$ Power Low Voltage Hall Effect Latch/Switch/Omnipolar  
Datasheet

## 12.3. Open Drain Output without Enable (MLX92216)

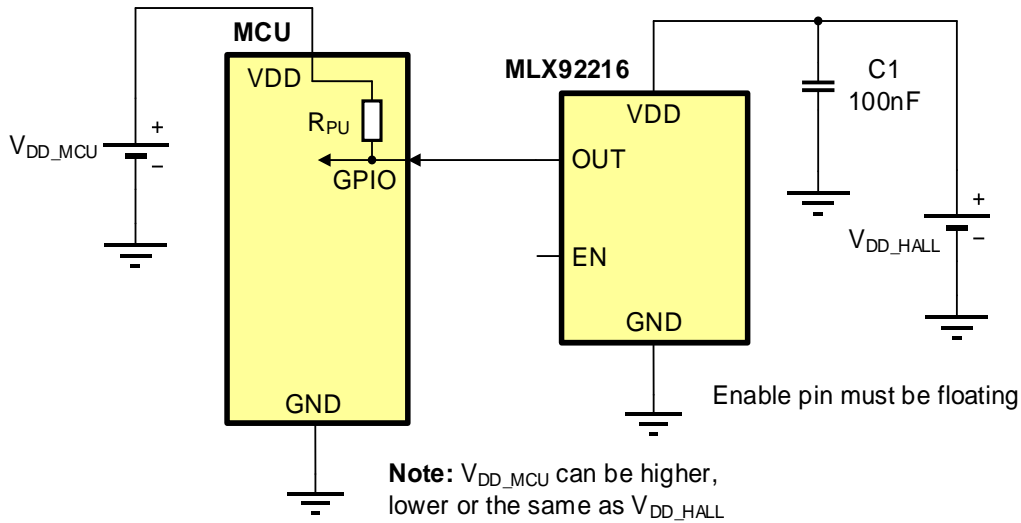

## 12.4. Open Drain Output with Enable (MLX92217)

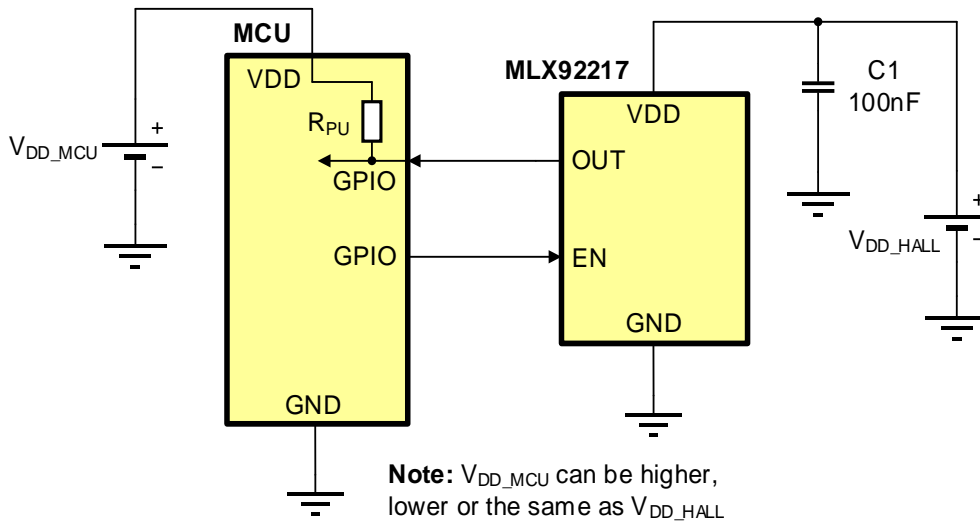

# MLX92216/MLX92217

3-wire  $\mu$ Power Low Voltage Hall Effect Latch/Switch/Omnipolar  
 Datasheet

## 13. Package Information

### 13.1. DFN-4L (LQ Package)

#### 13.1.1. DFN-4L – Package dimensions

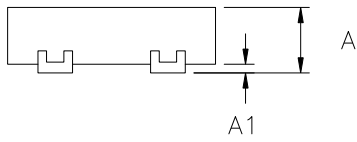
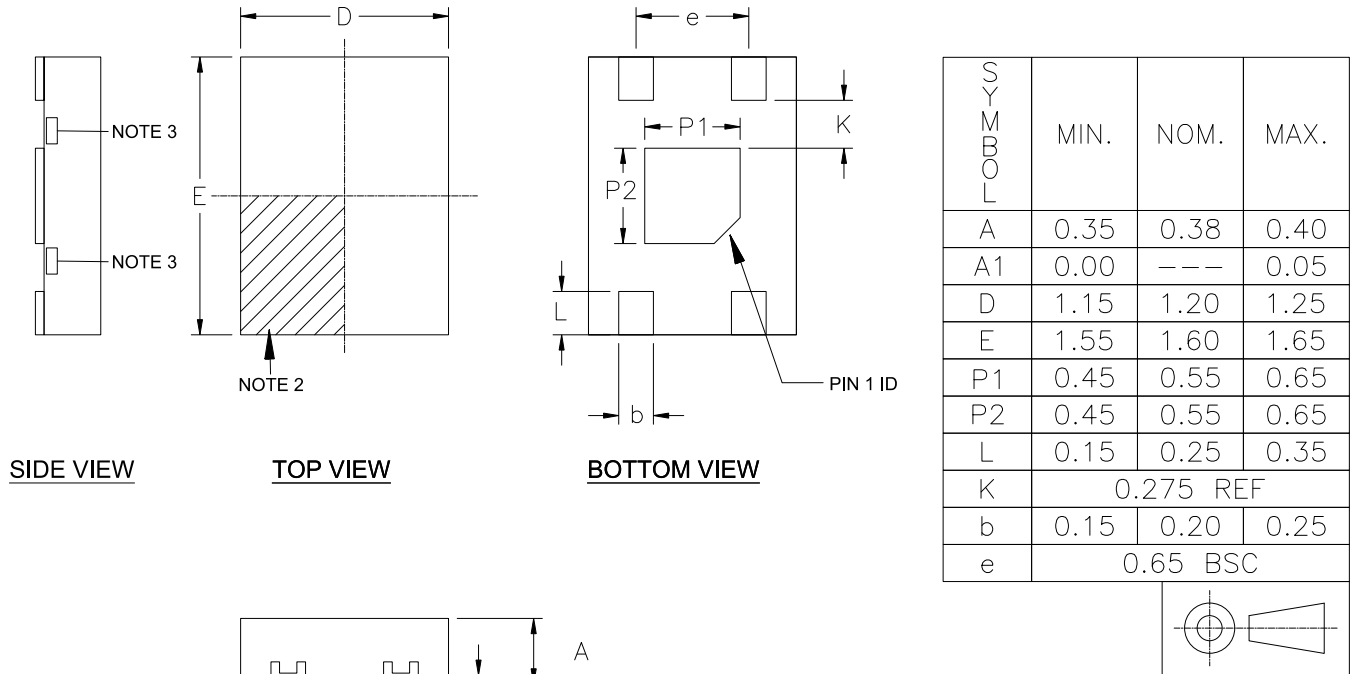

**SIDE VIEW**

NOTE :  
 1. ALL DIMENSIONS IN MILLIMETERS (mm).  
 2. TERMINAL #1 IDENTIFIER AND TERMINAL NUMBERING CONVENTION SHALL CONFORM JEDEC PUBLICATION 95 SPP-002. DETAILS OF TERMINAL #1 IDENTIFIER ARE OPTIONAL, BUT MUST BE LOCATED WITHIN THE ZONE IDENTICATED. THE TERMINAL #1 IDENTIFIER MAY BE MARKED FEATURE.  
 3. EXPOSED TIE BAR SHOULD BE KEPT FREE FROM SOLDER.

#### 13.1.2. DFN-4L – Sensitive spot

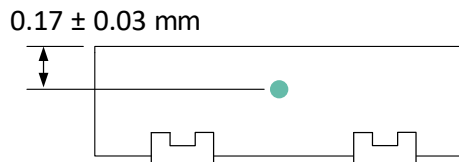
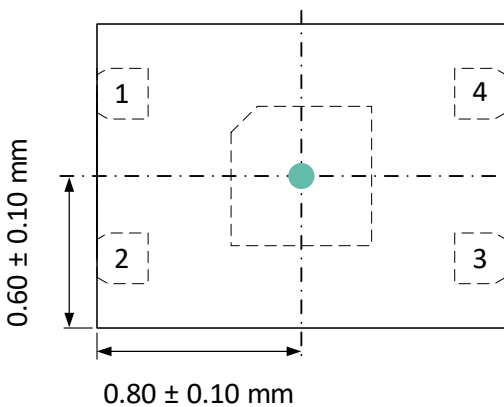

Notes:  
 1. Terminals and exposed pad are for illustration only.  
 2. Hall plate center is aligned to package center.

# MLX92216/MLX92217

3-wire  $\mu$ Power Low Voltage Hall Effect Latch/Switch/Omnipolar  
Datasheet

## 13.1.3. DFN-4L – Package marking / Pin definition

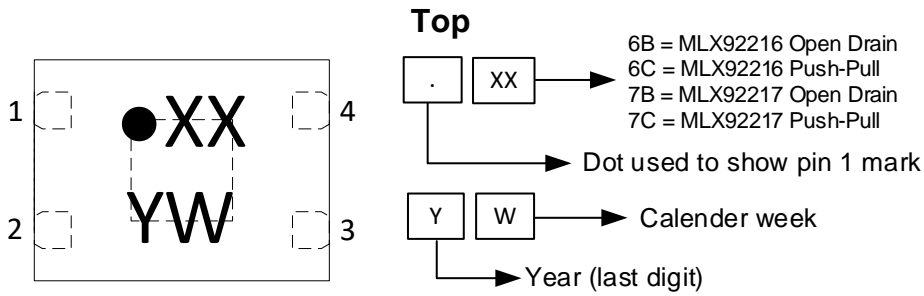

Pin #	Name	Type	Function
1	OUT	Output	Push-Pull or Open Drain
2	GND	Ground	Ground pin
3	EN*	Input	Chip Enable pin
4	VDD	Supply	Power supply pin

*The exposed pad can be soldered to the PCB to improve thermal dissipation. Can be connected to the ground potential or left floating.*

The Chip enable pin should be connected on MLX92217 versions, must be floating on MLX92216 versions.

# MLX92216/MLX92217

3-wire  $\mu$ Power Low Voltage Hall Effect Latch/Switch/Omnipolar  
 Datasheet

## 13.2. TSOT-3L (SE package)

### 13.2.1. TSOT-3L – Package dimensions

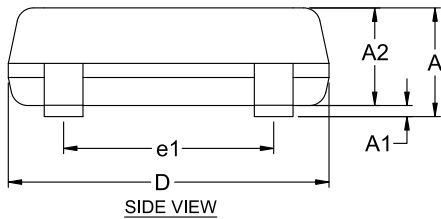
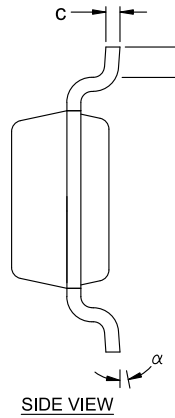
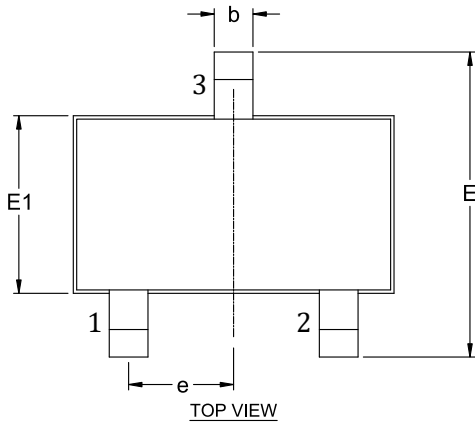

SYMBOL	MINIMUM	MAXIMUM
A	---	1.00
A1	0.025	0.10
A2	0.85	0.90
D	2.80	3.00
E	2.60	3.00
E1	1.50	1.70
L	0.30	0.50
b	0.30	0.45
c	0.10	0.20
e	0.95 BSC	
e1	1.90 BSC	
$\alpha$	0°	8°

NOTE :

1. ALL DIMENSIONS IN MILLIMETERS (mm) UNLESS OTHERWISE STATED.
2. DIMENSION D DOES NOT INCLUDE MOLD FLASH OR PROTRUSIONS OF MAX 0.15 mm PER SIDE.
3. DIMENSION E1 DOES NOT INCLUDE MOLD FLASH OR PROTRUSIONS OF MAX 0.25 mm PER SIDE.
4. DIMENSION b DOES NOT INCLUDE DAMBAR PROTRUSION OF MAX 0.07 mm.
5. DIMENSION L IS THE LENGTH OF THE TERMINAL FOR SOLDERING TO A SUBSTRATE.
6. FORMED LEAD SHALL BE PLANAR WITH RESPECT TO ONE ANOTHER WITH 0.076 mm SEATING PLANE.

### 13.2.2. TSOT-3L – Sensitive spot

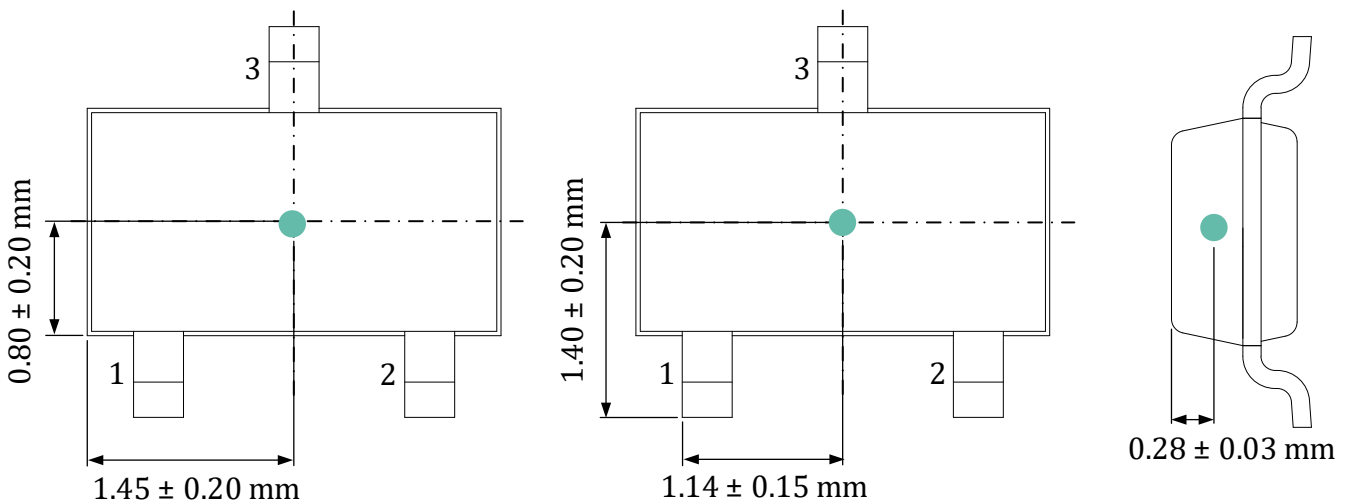

# MLX92216/MLX92217

3-wire  $\mu$ Power Low Voltage Hall Effect Latch/Switch/Omnipolar  
 Datasheet

## 13.2.3. TSOT-3L – Package marking/ Pin definition

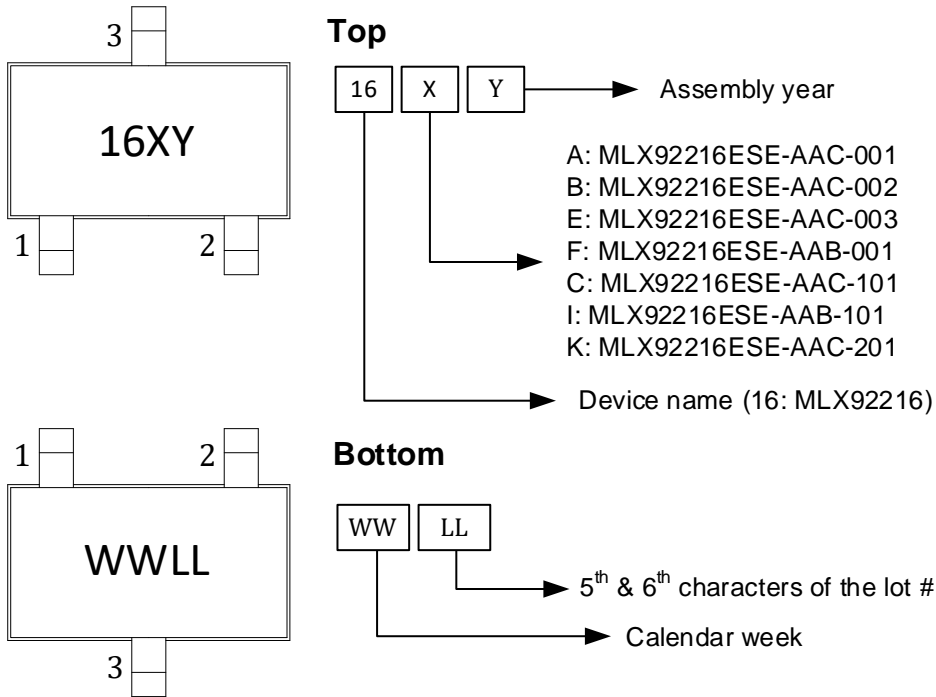

Pin #	Name	Type	Function
1	VDD	Supply	Supply Voltage pin
2	OUT	Out	Open drain/ Push-Pull
3	GND	Ground	Ground pin

# MLX92216/MLX92217

3-wire  $\mu$ Power Low Voltage Hall Effect Latch/Switch/Omnipolar  
Datasheet



## 14. IC handling and assembly

### 14.1. Storage and handling of plastic encapsulated ICs

Plastic encapsulated ICs shall be stored and handled according to their MSL categorization level (specified in the packing label) as per J-STD-033.

Electronic semiconductor products are sensitive to Electro Static Discharge (ESD). The component assembly shall be handled in EPA (Electrostatic Protected Area) as per ANSI S20.20

For more information refer to Melexis [Guidelines for storage and handling of plastic encapsulated ICs](#)<sup>(1)</sup>

### 14.2. Assembly of encapsulated ICs

For Surface Mounted Devices (SMD, as defined according to JEDEC norms), the only applicable soldering method is reflow.

For Through Hole Devices (THD), the applicable soldering methods are reflow, wave, selective wave and robot point-to-point. THD lead pre-forming (cutting and/or bending) is applicable under strict compliance with Melexis [Guidelines for lead forming of SIP Hall Sensors](#)<sup>(1)</sup>.

Melexis products soldering on PCB should be conducted according to the requirements of IPC/JEDEC and J-STD-001. Solder quality acceptance should follow the requirements of IPC-A-610.

For PCB-less assembly refer to the relevant application notes <sup>(1)</sup> or contact Melexis.

Electrical resistance welding or laser welding can be applied to Melexis products in THD and specific PCB-less packages following the [Guidelines for welding of PCB-less devices](#)<sup>(1)</sup>.

Environmental protection of customer assembly with Melexis products for harsh media application, is applicable by means of coating, potting or overmolding considering restrictions listed in the relevant application notes <sup>(1)</sup>

For other specific process, contact Melexis via [www.melexis.com/technical-inquiry](http://www.melexis.com/technical-inquiry)

### 14.3. Environment and sustainability

Melexis is contributing to global environmental conservation by promoting non-hazardous solutions. For more information on our environmental policy and declarations (RoHS, REACH...) visit [www.melexis.com/environmental-forms-and-declarations](http://www.melexis.com/environmental-forms-and-declarations)

---

<sup>1</sup> [www.melexis.com/ic-handling-and-assembly](http://www.melexis.com/ic-handling-and-assembly)

# MLX92216/MLX92217

3-wire  $\mu$ Power Low Voltage Hall Effect Latch/Switch/Omnipolar  
Datasheet



## 15. Disclaimer

*The content of this document is believed to be correct and accurate. However, the content of this document is furnished "as is" for informational use only and no representation, nor warranty is provided by Melexis about its accuracy, nor about the results of its implementation. Melexis assumes no responsibility or liability for any errors or inaccuracies that may appear in this document. Customer will follow the practices contained in this document under its sole responsibility. This documentation is in fact provided without warranty, term, or condition of any kind, either implied or expressed, including but not limited to warranties of merchantability, satisfactory quality, non-infringement, and fitness for purpose. Melexis, its employees and agents and its affiliates' and their employees and agents will not be responsible for any loss, however arising, from the use of, or reliance on this document. Notwithstanding the foregoing, contractual obligations expressly undertaken in writing by Melexis prevail over this disclaimer.*

*This document is subject to change without notice, and should not be construed as a commitment by Melexis. Therefore, before placing orders or prior to designing the product into a system, users or any third party should obtain the latest version of the relevant information. Users or any third party must determine the suitability of the product described in this document for its application, including the level of reliability required and determine whether it is fit for a particular purpose.*

*This document as well as the product here described may be subject to export control regulations. Be aware that export might require a prior authorization from competent authorities. The product is not designed, authorized or warranted to be suitable in applications requiring extended temperature range and/or unusual environmental requirements. High reliability applications, such as medical life-support or life-sustaining equipment or avionics application are specifically excluded by Melexis. The product may not be used for the following applications subject to export control regulations: the development, production, processing, operation, maintenance, storage, recognition or proliferation of:*

- 1. chemical, biological or nuclear weapons, or for the development, production, maintenance or storage of missiles for such weapons;*
- 2. civil firearms, including spare parts or ammunition for such arms;*
- 3. defense related products, or other material for military use or for law enforcement;*
- 4. any applications that, alone or in combination with other goods, substances or organisms could cause serious harm to persons or goods and that can be used as a means of violence in an armed conflict or any similar violent situation.*

*No license nor any other right or interest is granted to any of Melexis' or third party's intellectual property rights.*

*If this document is marked "restricted" or with similar words, or if in any case the content of this document is to be reasonably understood as being confidential, the recipient of this document shall not communicate, nor disclose to any third party, any part of the document without Melexis' express written consent. The recipient shall take all necessary measures to apply and preserve the confidential character of the document. In particular, the recipient shall (i) hold document in confidence with at least the same degree of care by which it maintains the confidentiality of its own proprietary and confidential information, but no less than reasonable care; (ii) restrict the disclosure of the document solely to its employees for the purpose for which this document was received, on a strictly need to know basis and providing that such persons to whom the document is disclosed are bound by confidentiality terms substantially similar to those in this disclaimer; (iii) use the document only in connection with the purpose for which this document was received, and reproduce document only to the extent necessary for such purposes; (iv) not use the document for commercial purposes or to the detriment of Melexis or its customers. The confidentiality obligations set forth in this disclaimer will have indefinite duration and in any case they will be effective for no less than 10 years from the receipt of this document.*

*This disclaimer will be governed by and construed in accordance with Belgian law and any disputes relating to this disclaimer will be subject to the exclusive jurisdiction of the courts of Brussels, Belgium.*

*The invalidity or ineffectiveness of any of the provisions of this disclaimer does not affect the validity or effectiveness of the other provisions. The previous versions of this document are repealed.*

*Melexis © - No part of this document may be reproduced without the prior written consent of Melexis. (2024)  
IATF 16949 and ISO 14001 Certified*

For the latest revision of this document, visit [www.melexis.com/MLX92216-MLX92217](http://www.melexis.com/MLX92216-MLX92217)  
Happy to help you! [www.melexis.com/contact](http://www.melexis.com/contact)