

MLX90823

Relative Pressure Sensor with analog output
Datasheet

1. Features and Benefits

- +/-0.5% full scale lifetime accuracy
- Ratiometric analog output
- Fast response time (min 0.4ms)
- All-in-one solution: MEMS, interface and passive components in one easy to integrate package validated according to leading OEM EMC standards
- -40°C to 160°C temperature range, up to 170°C for short durations
- Excellent harsh media resistance against halogens, acids, ...
- Qualified according to AEC-Q100 and AEC-Q103-002
- Configurable diagnostic features like internal broken connection, over voltage, under voltage, ...
- Factory calibrated and fully programmable through the connector with the PTC04 programming tool for customized calibration curves
- Extended over (+40V) and reverse (-40V) voltage capabilities (supply & output)
- Easy to use due to its PCB-less package with ridges to enable glued pressure seals
- ASIL compliant developed as an ASIL A SEooC as per ISO 26262

2. Application Examples

- Automotive applications with relative pressure spans from 0.05 bar to 1.5 bar
- Fuel vapor pressure sensor
- Crankcase ventilation pressure sensor
- Pressure sensor for filter monitoring

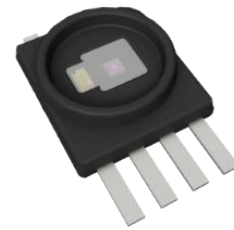

Figure 1: MLX90823

MLX90823

Relative Pressure Sensor with analog output
Datasheet

3. Ordering Information

Ordering Code	Temperature	Package	Option code	Packaging
MLX90823GXP-BAD-301-RE	-40°C to 160°C	SMP7	-0.2 to 0.5bar relative pressure 0.5V to 4.5V analog output	Reel
MLX90823GXP-BAF-305-RE	-40°C to 160°C	SMP7	-0.017 to 0.345bar relative pressure 0.5V to 4.5V analog output	Reel
MLX90823GXP-BAD-306-RE	-40°C to 160°C	SMP7	0 to -1.0bar relative pressure 0.5V to 4.5V analog output	Reel
MLX90823GXP-BAD-308-RE	-40°C to 160°C	SMP7	0 to 1.0bar relative pressure 0.5V to 4.5V analog output	Reel
MLX90823VXP-BAF-309-RE	-40°C to 115°C	SMP7	-0.0375 to 0.0125bar relative pressure 0.5V to 4.5V analog output	Reel

MLX90823GXP-BAD-301-RE

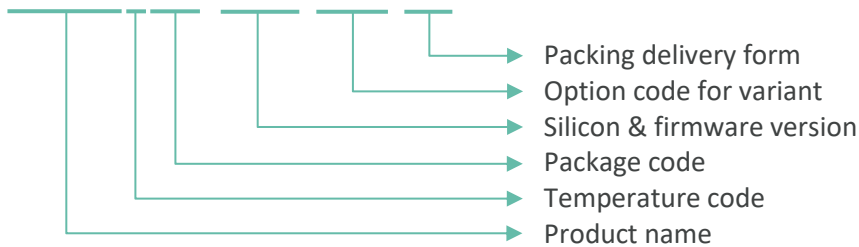

4. Package Diagram

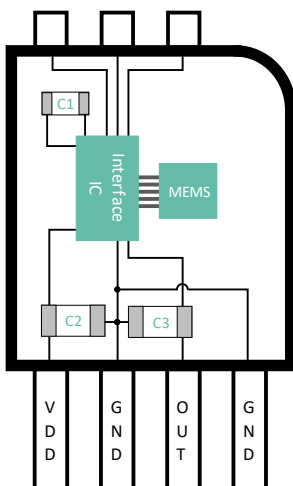

Figure 2: Internal wiring of MLX90823

Component	Value
C1	47nF
C2	100nF
C3	100nF

Table 1: MLX90823 capacitors configuration

MLX90823

Relative Pressure Sensor with analog output
Datasheet

5. General Description

The MLX90823 is a packaged PCB-less, factory calibrated, relative pressure sensor measuring spans from 0.1 bar to 1.5 bar. It delivers an analog output signal.

The MLX90823 consists of a MEMS pressure sensor element, an interface chip (CMOS technology) and passive components. This optimized solution exhibits excellent EMC performance. The DSP based signal interface provides outstanding initial accuracy. A smart package and die assembly concept enable high output stability over life, even in stringent automotive temperature and stress conditions.

Contents

1. Features and Benefits.....	1
2. Application Examples.....	1
3. Ordering Information	2
4. Package Diagram	2
5. General Description.....	3
6. Glossary of Terms.....	4
7. Absolute Maximum Ratings	5
8. Pin Definitions and Descriptions	6
9. General Electrical Specifications	7
10. Detailed General Description.....	8
11. Default programmed settings.....	9
11.1. MLX90823GXP-BAD-301	11
11.2. MLX90823GXP-BAF-305	11
11.3. MLX90823GXP-BAD-306	12
11.4. MLX90823GXP-BAD-308	12
11.5. MLX90823VXP-BAF-309	13
12. Diagnostics	14
12.1. Broken Connection Diagnostics	14
12.2. Internal Diagnostics.....	14
13. Digital	15
14. Application Information.....	16
15. Storage and Handling of Plastic Encapsulated ICs	17
16. Assembly of Encapsulated ICs.....	17
17. Environment and Sustainability	17
18. Package Information.....	18
19. Disclaimer.....	19

MLX90823

Relative Pressure Sensor with analog output
Datasheet

6. Glossary of Terms

Relative pressure: Pressure difference between applied pressure on the top side and atmospheric pressure on the bottom side

ADC: Analog to Digital Converter

Bar: Pressure unit (1bar = 100kPa)

DSP: Digital Signal Processor

EMC: Electro Magnetic Compatibility

FS: Full scale, span

Lower Fault Band: Output voltage below normal output range to indicate a diagnostic

OV: Over Voltage

PCB: Printed Circuit Board

POR: Power-on Reset

PTC04: Melexis Programming Tool

RV: Reverse Voltage

SEoC: Safety Element out of Context

TA: Ambient temperature

Upper Fault Band: Output voltage above normal output range to indicate a diagnostic

MLX90823

Relative Pressure Sensor with analog output
Datasheet

7. Absolute Maximum Ratings

Parameter	Symbol	Value	Units	Comment
Supply Voltage (overvoltage)	OV	40	V	Max 2 hours
Reverse Voltage Protection	RV	-40	V	
Positive output voltage		40	V	
Reverse output voltage ⁽¹⁾		-40	V	
Operating Ambient Temperature Range	T _A	-40 to 160	°C	
Extended Operating Ambient Temperature Range		-40 to 170	°C	10 minutes continuous period, max 20 hours total duration over life
Storage Temperature Range		-40 to 160	°C	
Programming Ambient Temperature Range		-40 to 125	°C	
Proof pressure (top side)		5	Bar	
Burst pressure (top side)		7	Bar	
Proof pressure (bottom side)		5	Bar	
Burst pressure (bottom side)		5	Bar	

Table 2: Absolute maximum ratings

Exceeding the absolute maximum ratings may cause permanent damage. Exposure to absolute-maximum-rated conditions for extended periods may affect device reliability.

¹ Absolute maximum DC negative output at floating supply or supply shorted to output. Maximum DC negative output at operating supply: -5.5V.

MLX90823

Relative Pressure Sensor with analog output
 Datasheet

8. Pin Definitions and Descriptions

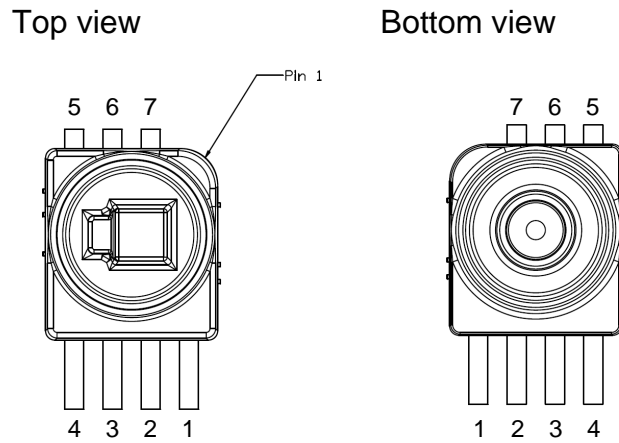

Figure 3: Package pinout

Pin number	Description
1	Ground (GND) ⁽²⁾
2	Analog output
3	Ground (GND) ⁽²⁾
4	Supply input (VDD)
5	Test pin
6	Test pin
7	Test pin

Table 3: Pinout definitions and descriptions

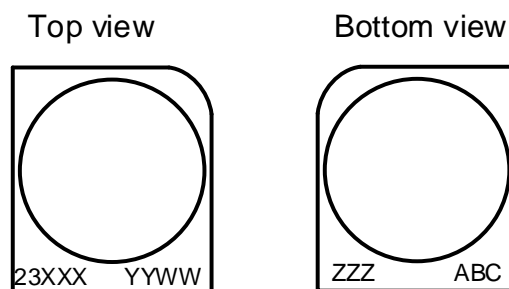

Figure 4: Package marking

Symbol	Function / Description
XXX	MEMS and ASIC traceability letter ⁽³⁾
ZZZ	Last three characters of lot number
ABC	Sub lot indication
YYWW	Date code

Table 4: Package marking definition

² Either pin 1 or pin 3 can be used as Ground (GND) connection, it is not required to connect both pins. The unused pin may be left floating.

³ Linked to first three letters of option code.

MLX90823

Relative Pressure Sensor with analog output
Datasheet

9. General Electrical Specifications

DC Operating Parameters $T_A = -40^{\circ}\text{C}$ to 160°C

Parameter	Symbol	Remarks	Min	Typ ⁽⁴⁾	Max	Units
Nominal supply voltage	Vdd		4.5	5	5.5	V
Nominal supply current	Idd	No output load		9.5	12	mA
Current consumption at supply overvoltage	IDD_OV				20	mA
Current consumption at supply reverse voltage	IDD_RV				20	mA
Output short-circuit current	IOUT_SH				20	mA
Resistive load on output	Rload	Pull up	3		425	kOhm
		Pull down	3		470	kOhm
Capacitive load on output	Cload	MLX90823 has an integrated 100nF output capacitor in its package. No additional capacitor needed.	0		110	nF
Output current	IOUT				2	mA
Under voltage detection range		Programmable. In default configuration set to 4.3V.	4.15		4.8	V
Over voltage detection range		Programmable. In default configuration set to 5.7V.	5.2		5.75	V
Under voltage detection tolerance			-50		50	mV
Over voltage detection tolerance			-50		50	mV
Power up time		Time from reaching minimum allowed supply voltage of 4.5V till having the output within specification			4	ms
Default response time ⁽⁵⁾		Default configuration BAD-301, BAF-305, BAD-306, BAD-308			1	ms
Fastest response time ⁽⁵⁾					0.4	ms
Refresh rate		Time between two consecutive updates on the output			75	μs
Operating Output voltage range		Output range where the linearity is in spec with any resistive load inside the specified range	4		96	%Vdd
Upper Fault Band			97		100	%Vdd
Lower Fault Band			0		3	%Vdd
Pressure output noise		Default configuration BAD-301, BAF-305, BAD-306, BAD-308			2	mV rms

Table 5: Electrical specifications

⁴ Typical values are defined at $T_A = +25^{\circ}\text{C}$ and $V_{DD} = 5\text{V}$.

⁵ From input pressure step to output reaching 90% of settled output.

MLX90823

Relative Pressure Sensor with analog output
Datasheet

10. Detailed General Description

The MLX90823 consists of a pressure sensor element, a DSP-based interface chip and passive components.

The pressure sensor element consists of a diaphragm realized in the silicon chip by etching. The diaphragm reacts to a change in relative pressure between the top and bottom side. The internal strain increases, in particular at the border of the diaphragm. Here, the piezo-resistive elements have been implanted into the silicon diaphragm forming a Wheatstone bridge, which act as a transducer.

The analog front-end of the interface chip applies filtering and converts the analog signal to a digital value. The DSP performs the compensations over temperature. Furthermore, the digital circuit provides some filtering, the possibility to linearize the pressure signal and also implements the clamping function. This chip has an analog output proportional to the pressure and supply voltage. A broken wire detection block ensures the analog output goes to one of the rails in case of a broken supply or ground connection.

Extensive protection of the supply lines and output allows the MLX90823 to handle extreme overvoltage conditions and makes it resistant to severe external disturbances. Several diagnostic functions (over-voltage, under-voltage, overpressure, under pressure detections) have been implemented on the MLX90823 and can be enabled by programming EEPROM settings. Figure 5 shows the MLX90823 block diagram. Passive components are integrated in the package to bring excellent EMC performance without the need for additional components at module level.

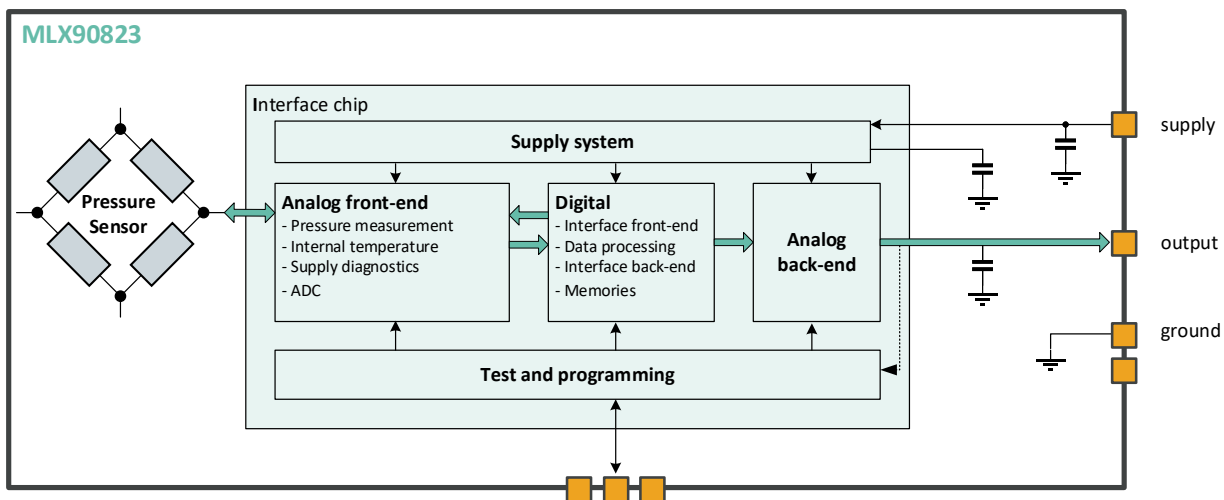

Figure 5: MLX90823 block diagram

MLX90823

Relative Pressure Sensor with analog output
 Datasheet

11. Default programmed settings

The MLX90823 is calibrated at the final manufacturing test steps. During the calibration, settings are stored in the on chip EEPROM to define the pressure transfer curve.

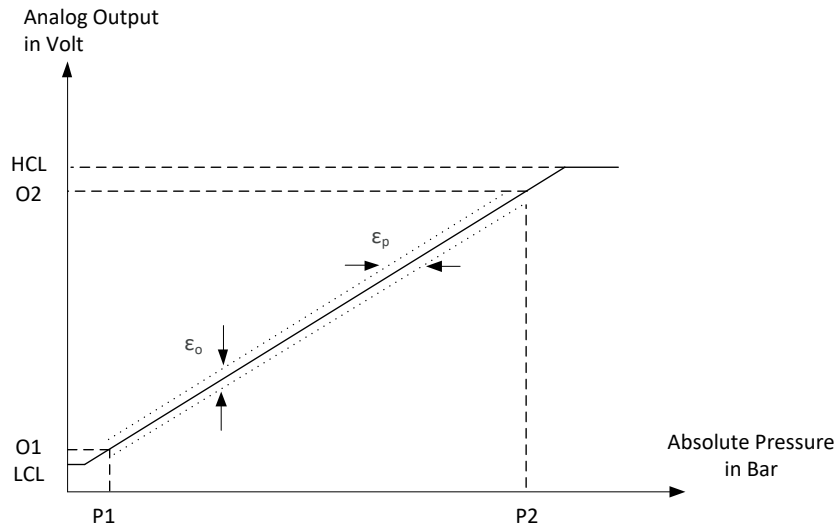

Figure 6: Pressure transfer function description at room temperature

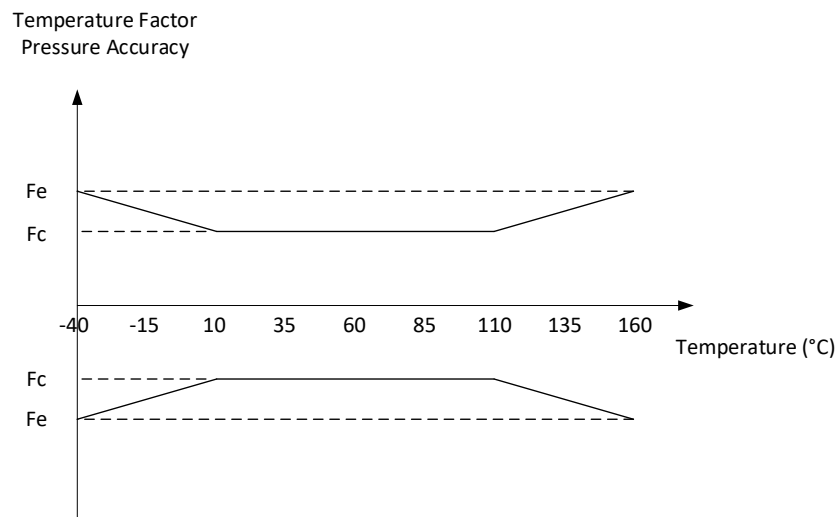

Figure 7: Pressure accuracy temperature factor (G temperature code)

MLX90823

Relative Pressure Sensor with analog output
Datasheet

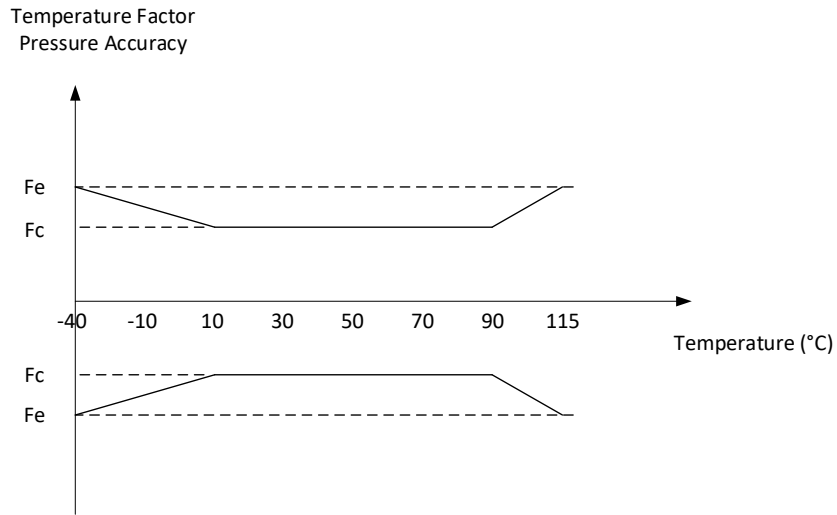

Figure 8: Pressure accuracy temperature factor (V temperature code)

MLX90823

Relative Pressure Sensor with analog output
Datasheet

11.1. MLX90823GXP-BAD-301

Transfer Curve Parameter	Symbol	Remarks	Value			Unit
Pressure 1	P1	See Figure 6: Pressure transfer function description at room temperature	-0.2			Bar
Pressure 2	P2		0.5			Bar
Output 1	O1		0.5			V
Output 2	O2		4.5			V
Low clamping level	LCL		0.3			V
High clamping level	HCL		4.7			V
Pressure Accuracy Parameter	Symbol	Remarks	Min	Typ	Max	Unit
Output accuracy	ϵ_o	Overall accuracy expressed as output value (FS range from 0.5V to 4.5V)	-20 -0.5		20 0.5	mV %FS
Pressure accuracy	ϵ_p	Overall accuracy expressed as pressure value	-3.5		3.5	mBar
Center temperature accuracy factor	Fc	See Figure 7: Pressure accuracy temperature factor (G temperature code)			1	
Extended temperature accuracy factor	Fe				1.5	

Table 6: BAD-301 Default configuration

11.2. MLX90823GXP-BAF-305

Transfer Curve Parameter	Symbol	Remarks	Value			Unit
Pressure 1	P1	See Figure 6: Pressure transfer function description at room temperature	-0.017			Bar
Pressure 2	P2		0.345			Bar
Output 1	O1		0.5			V
Output 2	O2		4.5			V
Low clamping level	LCL		0.3			V
High clamping level	HCL		4.7			V
Pressure Accuracy Parameter	Symbol	Remarks	Min	Typ	Max	Unit
Output accuracy	ϵ_o	Overall accuracy expressed as output value (FS range from 0.5V to 4.5V)	-40 -1.00		40 1.00	mV %FS
Pressure accuracy	ϵ_p	Overall accuracy expressed as pressure value	3.6		3.6	mBar
Center temperature accuracy factor	Fc	See Figure 7: Pressure accuracy temperature factor (G temperature code)			1	
Extended temperature accuracy factor	Fe				1.5	

Table 7: BAF-305 Default Configuration

MLX90823

Relative Pressure Sensor with analog output
Datasheet

11.3. MLX90823GXP-BAD-306

Transfer Curve Parameter	Symbol	Remarks	Value			Unit
Pressure 1	P1	See Figure 6: Pressure transfer function description at room temperature	0			Bar
Pressure 2	P2		-1.0			Bar
Output 1	O1		0.5			V
Output 2	O2		4.5			V
Low clamping level	LCL		0.3			V
High clamping level	HCL		4.7			V
Pressure Accuracy Parameter	Symbol	Remarks	Min	Typ	Max	Unit
Output accuracy	ϵ_o	Overall accuracy expressed as output value (FS range from 0.5V to 4.5V)	-20 -0.5		20 0.5	mV %FS
Pressure accuracy	ϵ_p	Overall accuracy expressed as pressure value	-5		5	mBar
Center temperature accuracy factor	Fc	See Figure 7: Pressure accuracy temperature factor (G temperature code)			1	
Extended temperature accuracy factor	Fe				1.5	

Table 8: BAD-306 Default Configuration

11.4. MLX90823GXP-BAD-308

Transfer Curve Parameter	Symbol	Remarks	Value			Unit
Pressure 1	P1	See Figure 6: Pressure transfer function description at room temperature	0			Bar
Pressure 2	P2		1.0			Bar
Output 1	O1		0.5			V
Output 2	O2		4.5			V
Low clamping level	LCL		0.3			V
High clamping level	HCL		4.7			V
Pressure Accuracy Parameter	Symbol	Remarks	Min	Typ	Max	Unit
Output accuracy	ϵ_o	Overall accuracy expressed as output value (FS range from 0.5V to 4.5V)	-20 -0.5		20 0.5	mV %FS
Pressure accuracy	ϵ_p	Overall accuracy expressed as pressure value	-5		5	mBar
Center temperature accuracy factor	Fc	See Figure 7: Pressure accuracy temperature factor (G temperature code)			1	
Extended temperature accuracy factor	Fe				1.5	

Table 9: BAD-308 Default Configuration

MLX90823

Relative Pressure Sensor with analog output
Datasheet

11.5. MLX90823VXP-BAF-309

Transfer Curve Parameter	Symbol	Remarks	Value			Unit
Pressure 1	P1	See Figure 6: Pressure transfer function description at room temperature	-0.0375			Bar
Pressure 2	P2		0.0125			Bar
Output 1	O1		0.5			V
Output 2	O2		4.5			V
Low clamping level	LCL		0.3			V
High clamping level	HCL		4.7			V
Pressure Accuracy Parameter	Symbol	Remarks	Min	Typ	Max	Unit
Output accuracy	ϵ_o	Overall accuracy expressed as output value (FS range from 0.5V to 4.5V)	-100 -2.5		100 2.5	mV %FS
Pressure accuracy	ϵ_p	Overall accuracy expressed as pressure value	-1.25		1.25	mBar
Center temperature accuracy factor	Fc	See Figure 8: Pressure accuracy temperature factor (V temperature code)			1	
Extended temperature accuracy factor	Fe				1.25	

Table 10: BAF-309 Default Configuration

MLX90823

Relative Pressure Sensor with analog output
Datasheet

12. Diagnostics

The MLX90823 has built in diagnostics which can flag fault conditions. This is done by having an output set to 0V or 5V, this is beyond the upper and lower clamp levels of a valid output signal. There are two groups. The first is the broken connection diagnostic which triggers when the device is connected incorrectly. The second group consists of the internal diagnostics, these are used to flag abnormal states during operation.

12.1. Broken Connection Diagnostics

Table 11 shows the output behavior of the MLX90823 if a connection is broken or incorrect.

GND	VDD	Analog out	Effect on output	Action after wrong connection
0V	5V	Pull-down or Pull-up	Normal operation	Normal operation
Disconnected	5V	Pull-down or Pull-up	Lower Fault Band for Pull-down Upper Fault Band for Pull-up	Normal operation
0V	Disconnected	Pull-down or Pull-up	Low Fault Band for Pull-down Upper Fault Band for Pull-up	Normal operation
0V	5V	Disconnected	Low Fault Band for Pull-down Upper Fault Band for Pull-up	Normal operation
0V	5V	0V	Low Fault Band	Normal operation
0V	5V	5V	Upper Fault Band	Normal operation

Table 11: Broken connections

12.2. Internal Diagnostics

The MLX90823 has several internal checks which monitor the status of the device. These checks or diagnostic sources can be enabled or disabled based on the sensor module requirements. It's possible to separately define some sources to appear as a Low Fault Band error and others as a High Fault Band. Table 12 shows the available diagnostic sources which can be programmed to result in either a high fault band output or low fault band output.

Bit	Error condition	Default settings
0	Supply voltage too high	Disabled
1	Supply voltage too low	Disabled
2	Internal error	Lower Fault Band
3	Broken pressure membrane	Lower Fault Band
4	Pressure parameter error	Lower Fault Band
5	Pressure output error	Lower Fault Band
6	Internal regulator out of range	Disabled

Table 12: Diagnostic sources

MLX90823

Relative Pressure Sensor with analog output
Datasheet

13. Digital

The digital is built around a 16-bit microcontroller. It contains besides the processor also ROM, RAM and EEPROM and a set of user and system IO registers. Temperature compensation of the pressure signal and pressure linearization is handled by the microcontroller. For the pressure compensation there are EEPROM parameters allocated to be able to cover a large variety of calibration approaches.

Both for gain and offset of the pressure signal, there is a separate temperature dependency which is programmable up to a third order compensation. This is reflected in EEPROM parameters for the offset (O0, O1, O2 and O3) and for the gain (G0, G1, G2 and G3).

If required, the linearity of the pressure signal can also be compensated with a first order temperature dependency through EEPROM parameters L0 and L1.

MLX90823

Relative Pressure Sensor with analog output
Datasheet

14. Application Information

The MLX90823 has two GND pins, only one needs to be connected in the application. The calibrated pressure ranges are defined as the pressure applied to the gel side as shown in Figure 9.

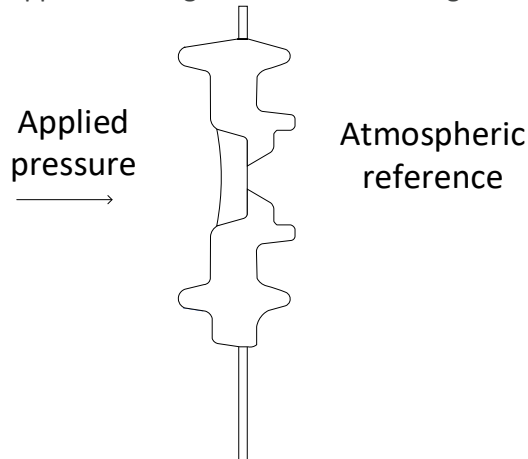

Figure 9: Pressure application

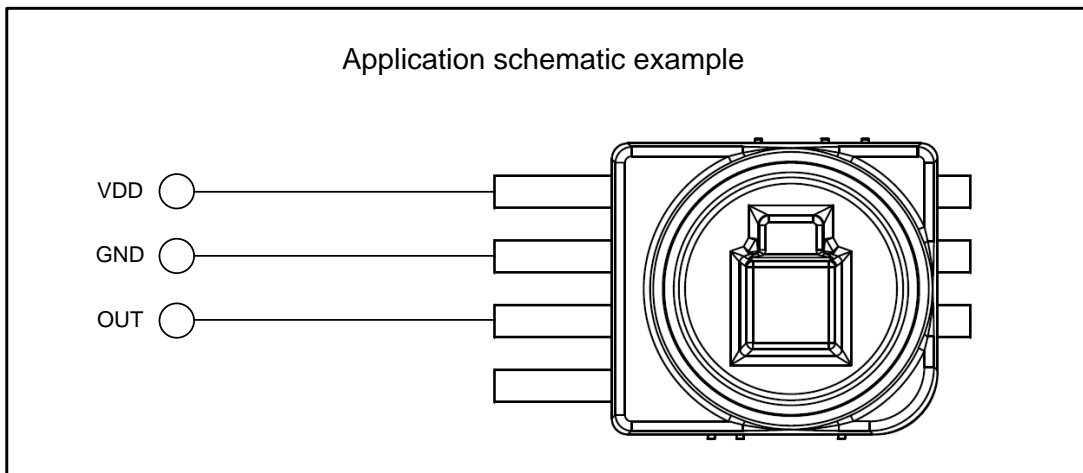

Figure 10: Basic application example with pin 3 as GND

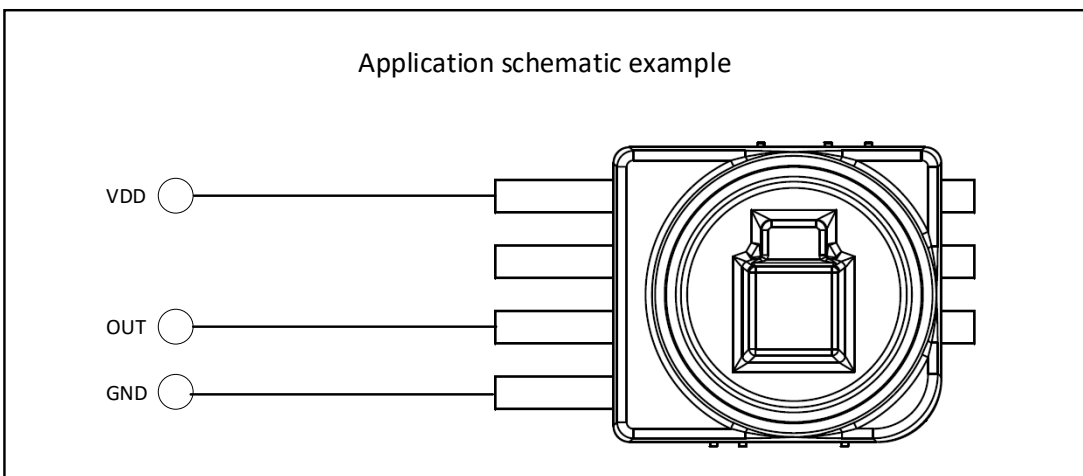

Figure 11: Basic application example with pin 1 as GND

MLX90823

Relative Pressure Sensor with analog output
Datasheet

15. Storage and Handling of Plastic Encapsulated ICs

Plastic encapsulated ICs shall be stored and handled according to their MSL categorization level (specified in the packing label) as per J-STD-033.

Electronic semiconductor products are sensitive to Electro Static Discharge (ESD). The component assembly shall be handled in EPA (Electrostatic Protected Area) as per ANSI S20.20

For more information refer to Melexis [Guidelines for storage and handling of plastic encapsulated ICs](#) ⁽⁶⁾

16. Assembly of Encapsulated ICs

For Surface Mounted Devices (SMD, as defined according to JEDEC norms), the only applicable soldering method is reflow.

For Through Hole Devices (THD), the applicable soldering methods are reflow, wave, selective wave and robot point-to-point. THD lead pre-forming (cutting and/or bending) is applicable under strict compliance with Melexis [Guidelines for lead forming of SIP Hall Sensors](#) ⁽⁶⁾.

Melexis products soldering on PCB should be conducted according to the requirements of IPC/JEDEC and J-STD-001. Solder quality acceptance should follow the requirements of IPC-A-610.

For PCB-less assembly refer to the relevant application notes ⁽⁶⁾ or contact Melexis.

Electrical resistance welding or laser welding can be applied to Melexis products in THD and specific PCB-less packages following the [Guidelines for welding of PCB-less devices](#) ⁽⁶⁾.

Environmental protection of customer assembly with Melexis products for harsh media application, is applicable by means of coating, potting or overmolding considering restrictions listed in the relevant application notes ⁽⁶⁾

For other specific process, contact Melexis via www.melexis.com/technical-inquiry

17. Environment and Sustainability

Melexis is contributing to global environmental conservation by promoting non-hazardous solutions. For more information on our environmental policy and declarations (RoHS, REACH...) visit www.melexis.com/environmental-forms-and-declarations

⁶ www.melexis.com/ic-handling-and-assembly

18. Package Information

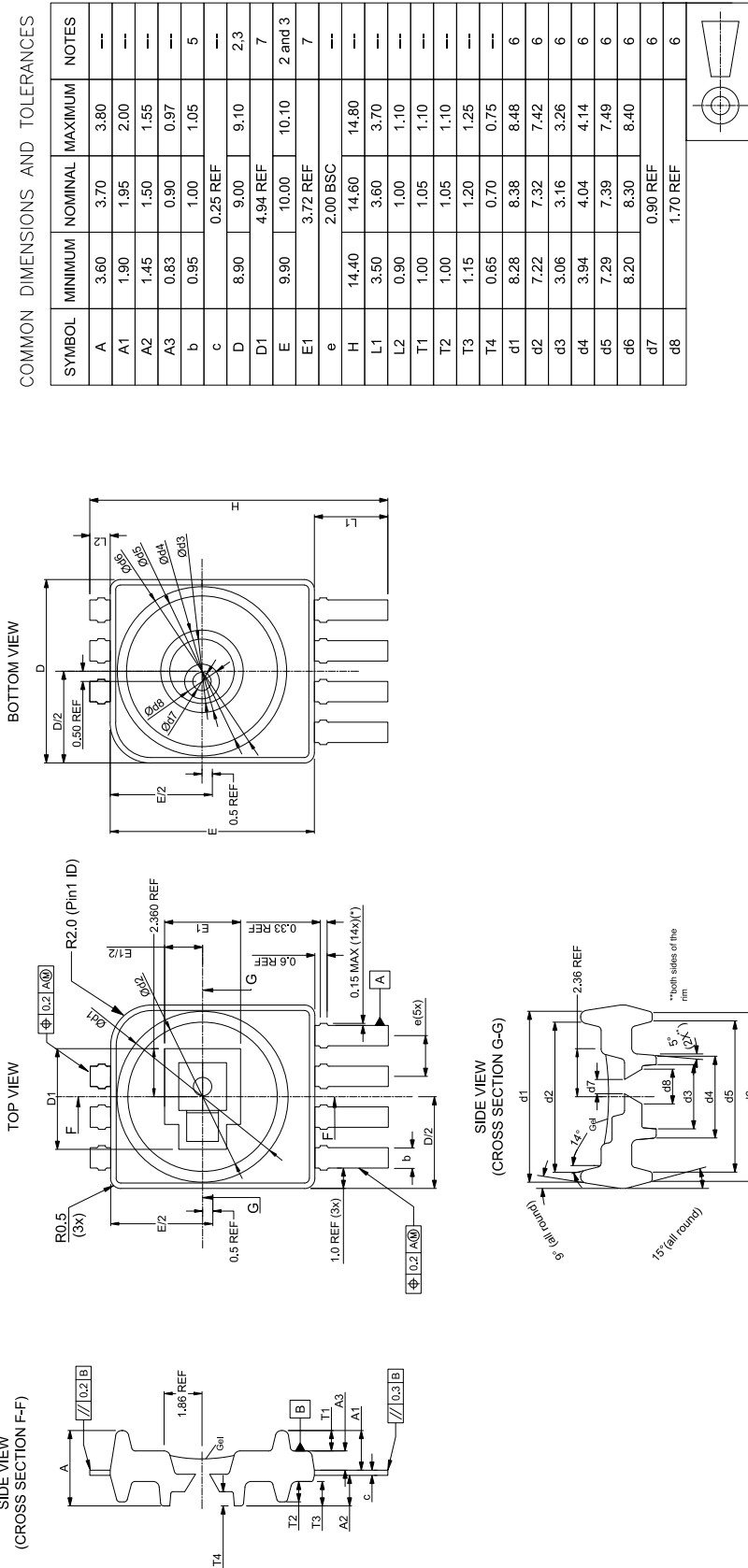

COMMON DIMENSIONS AND TOLERANCES

SYMBOL	MINIMUM	NOMINAL	MAXIMUM	NOTES
A	3.60	3.70	3.80	--
A1	1.90	1.95	2.00	--
A2	1.45	1.50	1.55	--
A3	0.83	0.90	0.97	--
b	0.95	1.00	1.05	5
c	0.25 REF			--
D	8.90	9.00	9.10	2,3
D1	4.94 REF			7
E	9.90	10.00	10.10	2 and 3
E1	3.72 REF			7
e	2.00 BSC			--
H	14.40	14.60	14.80	--
L1	3.50	3.60	3.70	--
L2	0.90	1.00	1.10	--
T1	1.00	1.05	1.10	--
T2	1.00	1.05	1.10	--
T3	1.15	1.20	1.25	--
T4	0.65	0.70	0.75	--
d1	8.28	8.38	8.48	6
d2	7.22	7.32	7.42	6
d3	3.06	3.16	3.26	6
d4	3.94	4.04	4.14	6
d5	7.29	7.39	7.49	6
d6	8.20	8.30	8.40	6
d7	0.90 REF			6
d8	1.70 REF			6

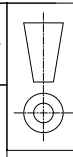

- Note:
1. ALL DIMENSIONS IN MILLIMETERS (mm) UNLESS NOTED OTHERWISE.
 2. PACKAGE DIMENSIONS "D", "E" AND "R2.0" DO NOT INCLUDE MOLD FLASHES, PROTRUSIONS OR GATE BURRS. CONTACT MELEXIS FOR SPECIFIC DESIGN RECOMMENDATIONS.
 3. PACKAGE TOP SURFACE MAY BE SMALLER THAN PACKAGE BOTTOM.
 4. SHINY SURFACE OUTLOOK DUE TO USE OF FILM.
 5. DIMENSION "b" DOES NOT INCLUDE DAMBARK() PROTRUSION.
 6. MIN AND MAX VALUES DEPEND ON THE RADIUS OF THE RIM WHICH CAN VARY FROM POSITION TO POSITION.
 7. DIMENSIONS "D1" AND "E1" CORRESPOND TO THE GEL FILLED CAVITY. ANY MECHANICAL CONTACT WITHIN MINIMUM DIAMETER OF "d2" SHOULD BE AVOIDED AT ALL TIME. CONTACT MELEXIS FOR SPECIFIC DESIGN RECOMMENDATIONS.

Figure 12: MLX90823 package drawing

MLX90823

Relative Pressure Sensor with analog output
Datasheet

19. Disclaimer

The content of this document is believed to be correct and accurate. However, the content of this document is furnished "as is" for informational use only and no representation, nor warranty is provided by Melexis about its accuracy, nor about the results of its implementation. Melexis assumes no responsibility or liability for any errors or inaccuracies that may appear in this document. Customer will follow the practices contained in this document under its sole responsibility. This documentation is in fact provided without warranty, term, or condition of any kind, either implied or expressed, including but not limited to warranties of merchantability, satisfactory quality, non-infringement, and fitness for purpose. Melexis, its employees and agents and its affiliates' and their employees and agents will not be responsible for any loss, however arising, from the use of, or reliance on this document. Notwithstanding the foregoing, contractual obligations expressly undertaken in writing by Melexis prevail over this disclaimer.

This document is subject to change without notice, and should not be construed as a commitment by Melexis. Therefore, before placing orders or prior to designing the product into a system, users or any third party should obtain the latest version of the relevant information.

Users or any third party must determine the suitability of the product described in this document for its application, including the level of reliability required and determine whether it is fit for a particular purpose.

This document as well as the product here described may be subject to export control regulations. Be aware that export might require a prior authorization from competent authorities. The product is not designed, authorized or warranted to be suitable in applications requiring extended temperature range and/or unusual environmental requirements. High reliability applications, such as medical life-support or life-sustaining equipment or avionics application are specifically excluded by Melexis. The product may not be used for the following applications subject to export control regulations: the development, production, processing, operation, maintenance, storage, recognition or proliferation of:

- 1. chemical, biological or nuclear weapons, or for the development, production, maintenance or storage of missiles for such weapons;*
- 2. civil firearms, including spare parts or ammunition for such arms;*
- 3. defense related products, or other material for military use or for law enforcement;*
- 4. any applications that, alone or in combination with other goods, substances or organisms could cause serious harm to persons or goods and that can be used as a means of violence in an armed conflict or any similar violent situation.*

No license nor any other right or interest is granted to any of Melexis' or third party's intellectual property rights.

If this document is marked "restricted" or with similar words, or if in any case the content of this document is to be reasonably understood as being confidential, the recipient of this document shall not communicate, nor disclose to any third party, any part of the document without Melexis' express written consent. The recipient shall take all necessary measures to apply and preserve the confidential character of the document. In particular, the recipient shall (i) hold document in confidence with at least the same degree of care by which it maintains the confidentiality of its own proprietary and confidential information, but no less than reasonable care; (ii) restrict the disclosure of the document solely to its employees for the purpose for which this document was received, on a strictly need to know basis and providing that such persons to whom the document is disclosed are bound by confidentiality terms substantially similar to those in this disclaimer; (iii) use the document only in connection with the purpose for which this document was received, and reproduce document only to the extent necessary for such purposes; (iv) not use the document for commercial purposes or to the detriment of Melexis or its customers. The confidentiality obligations set forth in this disclaimer will have indefinite duration and in any case they will be effective for no less than 10 years from the receipt of this document.

This disclaimer will be governed by and construed in accordance with Belgian law and any disputes relating to this disclaimer will be subject to the exclusive jurisdiction of the courts of Brussels, Belgium.

The invalidity or ineffectiveness of any of the provisions of this disclaimer does not affect the validity or effectiveness of the other provisions.

The previous versions of this document are repealed.

Melexis © - No part of this document may be reproduced without the prior written consent of Melexis. (2025)

IATF 16949 and ISO 14001 Certified