

MLX90815

Discrete Absolute Pressure Sensor

1. Features and Benefits

- High sensitivity
- Outstanding linearity
- High stability and reliability
- 0 – 10..30Bar Absolute pressure sensor
- Fully automotive qualified beyond AEC-Q100 requirements
- Compact design

2. Application Examples

- Automotive applications:
 - Engine/Transmission oil pressure
 - HVAC pressure
- Multi-Market:
 - HVAC/Refrigeration
 - Industrial process controls
 - Appliance
 - Consumer electronics
 - Ships and marine systems
 - Medical instruments

3. Ordering information

Product Code	Temperature Code	Package Code	Option Code	Packing form Code
MLX90815	L	UF	ACA-000	WB

Legend:

Temperature Code: L(-40°C to 150°C)
Package Code: UF=Die on Foil
Option Code: ACA-000
Packing Form: WB = Wafer Box
Ordering example: MLX90815LUF-ACA-000-WB

4. Functional Diagram

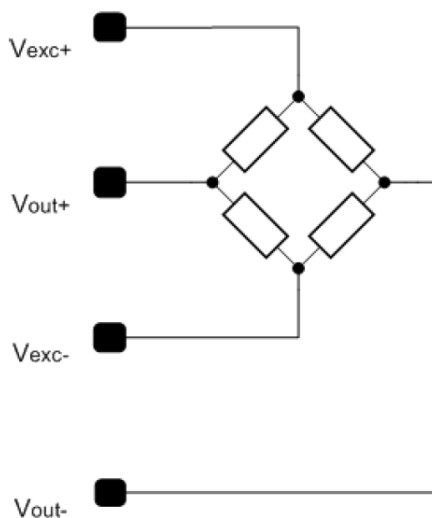

Figure 1: Functional block diagram MLX90815

5. General Description

The MLX90815 discrete micromachined absolute pressure sensors has been designed for an optimal performance when sensing pressures from 0 to 10..30 bar absolute. This device is fully automotive qualified. It can directly be used in non corrosive/non aggressive media applications. For harsh media, the MLX90815 can be used in a fluid filled module design. The sensor is a piezoresistive wheatstone bridge on a membrane made with a silicon micromachining process. As pressure is applied on the membrane a differential voltage change is seen across the Wheatstone bridge outputs while a bias voltage is applied to the bridge inputs.

The MLX90815 can be used in combination with the Melexis sensor interfaces ICs that can perform the conditioning of the bridge signal (MLX90328, MLX90329).

Contents

1. Features and Benefits.....	1
2. Application Examples.....	1
3. Ordering information.....	1
4. Functional Diagram	1
5. General Description.....	1
6. Absolute Maximum Ratings	3
7. Die Information	3
8. General Electrical Specifications	4
9. Application Information.....	4
10. Standard information regarding manufacturability of Melexis products with different soldering processes.....	5
11. ESD Precautions.....	5
12. Contact.....	6
13. Disclaimer.....	6

6. Absolute Maximum Ratings

Parameter	Sym bol	Min Value	Max Value	Units
Supply Voltage (overvoltage)	V_{brg}		10	V
Operating Temperature Range	T_A	-40	150	°C
Storage Temperature Range	T_S	- 55	150	°C
Burst Pressure			100	Bar

Table 1: Absolute maximum ratings

Exceeding the absolute maximum ratings may cause permanent damage. Exposure to absolute maximum rated conditions for extended periods may affect device reliability.

7. Die Information

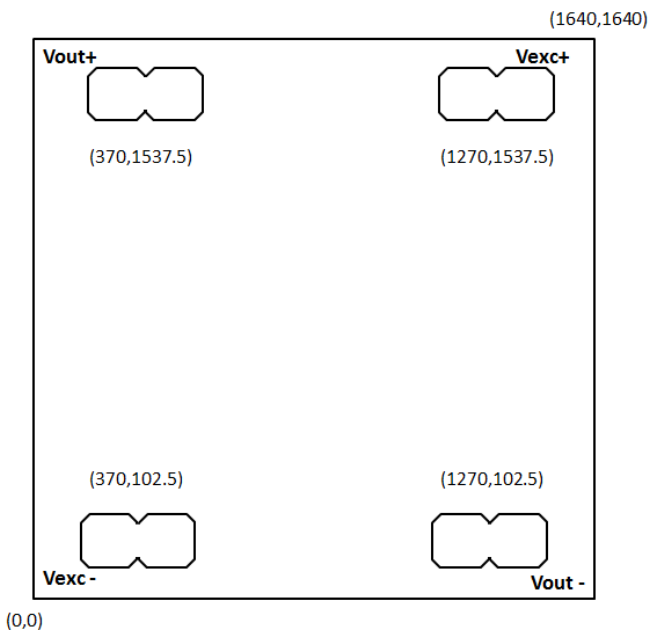

Figure 2: Chip Dimensions and bond pad positions (all dim. in μm)

Bond Pads opening size (x, y) in μm	Die thickness (μm)
(330,155)	700

Bond Pad	Function / Description
Vexc +	Supply voltage
Vout +	Positive output voltage
Vout -	Negative output voltage
Vexc -	Ground connection

Table 2: Bond pads description

8. General Electrical Specifications

DC Operating Parameters $T_A = 25\text{ }^\circ\text{C}$, $V_{DD} = 5\text{V}$, Pressure = 20 bar Full Scale unless otherwise specified.

Parameter	Symbol	Min	Max	Units
Sensitivity	S	1.3	1.8	mV/V/bar
Bridge Resistance	Rb	3	5.5	k Ω
Offset	O	-30	30	mV
Non linearity (best fit)	NL	-0.2	0.2	%FS
Thermal Hysteresis	Hyst	-0.2	0.2	%FS
Thermal coefficient of Span	TCS	-0.23	0.15	%FS/ $^\circ\text{C}$
Thermal coefficient of Offset	TCO	-0.06	0.06	%FS/ $^\circ\text{C}$
Thermal coefficient of bridge resistance	TCR	0.30	0.40	%FS/ $^\circ\text{C}$

Table 3: Electrical specifications

The MLX90815 can also be used with full scale pressures other than 20bar (10 to 30bar). Contact Melexis for detailed information on the IC performance at different full scale pressures.

9. Application Information

The MLX90815 is a very reliable discrete absolute pressure sensor fully automotive qualified. Like all Melexis pressure sensors it has been qualified beyond typical semiconductors qualification standards. For harsh media applications the MLX90815 can be used in a fluid filled housing.

If the application requires an amplified conditioned output the MLX90815 can be used in combination with Melexis sensor interfaces IC like the MLX90328 and the MLX90329. By programming some calibration settings in the sensor interface IC the sensitivity and offset variations from part to part as well as their variations over temperature can be compensated for.

10. Standard information regarding manufacturability of Melexis products with different soldering processes

Our products are classified and qualified regarding soldering technology, solderability and moisture sensitivity level according to following test methods:

Reflow Soldering SMD's (Surface Mount Devices)

- IPC/JEDEC J-STD-020
Moisture/Reflow Sensitivity Classification for Nonhermetic Solid State Surface Mount Devices (classification reflow profiles according to table 5-2)
- EIA/JEDEC JESD22-A113
Preconditioning of Nonhermetic Surface Mount Devices Prior to Reliability Testing (reflow profiles according to table 2)

Wave Soldering SMD's (Surface Mount Devices) and THD's (Through Hole Devices)

- EN60749-20
Resistance of plastic- encapsulated SMD's to combined effect of moisture and soldering heat
- EIA/JEDEC JESD22-B106 and EN60749-15
Resistance to soldering temperature for through-hole mounted devices

Iron Soldering THD's (Through Hole Devices)

- EN60749-15
Resistance to soldering temperature for through-hole mounted devices

Solderability SMD's (Surface Mount Devices) and THD's (Through Hole Devices)

- EIA/JEDEC JESD22-B102 and EN60749-21
Solderability

For all soldering technologies deviating from above mentioned standard conditions (regarding peak temperature, temperature gradient, temperature profile etc) additional classification and qualification tests have to be agreed upon with Melexis.

The application of Wave Soldering for SMD's is allowed only after consulting Melexis regarding assurance of adhesive strength between device and board.

Melexis recommends reviewing on our web site the General Guidelines [soldering recommendation](http://www.melexis.com/Quality_soldering.aspx) (http://www.melexis.com/Quality_soldering.aspx) as well as [trim&form recommendations](http://www.melexis.com/Assets/Trim-and-form-recommendations-5565.aspx) (<http://www.melexis.com/Assets/Trim-and-form-recommendations-5565.aspx>).

Melexis is contributing to global environmental conservation by promoting **lead free** solutions. For more information on qualifications of **RoHS** compliant products (RoHS = European directive on the Restriction Of the use of certain Hazardous Substances) please visit the quality page on our website: <http://www.melexis.com/quality.aspx>

11. ESD Precautions

Electronic semiconductor products are sensitive to Electro Static Discharge (ESD). Always observe Electro Static Discharge control procedures whenever handling semiconductor products.

12. Contact

For the latest version of this document, go to our website at www.melexis.com.

For additional information, please contact our Direct Sales team and get help for your specific needs:

Europe, Africa	Telephone: +32 13 67 04 95
	Email : sales_europe@melexis.com
Americas	Telephone: +1 603 223 2362
	Email : sales_usa@melexis.com
Asia	Email : sales_asia@melexis.com

13. Disclaimer

The information furnished by Melexis herein ("Information") is believed to be correct and accurate. Melexis disclaims (i) any and all liability in connection with or arising out of the furnishing, performance or use of the technical data or use of the product(s) as described herein ("Product") (ii) any and all liability, including without limitation, special, consequential or incidental damages, and (iii) any and all warranties, express, statutory, implied, or by description, including warranties of fitness for particular purpose, non-infringement and merchantability. No obligation or liability shall arise or flow out of Melexis' rendering of technical or other services.

The Information is provided "as is" and Melexis reserves the right to change the Information at any time and without notice. Therefore, before placing orders and/or prior to designing the Product into a system, users or any third party should obtain the latest version of the relevant information to verify that the information being relied upon is current. Users or any third party must further determine the suitability of the Product for its application, including the level of reliability required and determine whether it is fit for a particular purpose.

The Information is proprietary and/or confidential information of Melexis and the use thereof or anything described by the Information does not grant, explicitly or implicitly, to any party any patent rights, licenses, or any other intellectual property rights.

This document as well as the Product(s) may be subject to export control regulations. Please be aware that export might require a prior authorization from competent authorities.

The Product(s) are intended for use in normal commercial applications. Unless otherwise agreed upon in writing, the Product(s) are not designed, authorized or warranted to be suitable in applications requiring extended temperature range and/or unusual environmental requirements. High reliability applications, such as medical life-support or life-sustaining equipment are specifically not recommended by Melexis.

The Product(s) may not be used for the following applications subject to export control regulations: the development, production, processing, operation, maintenance, storage, recognition or proliferation of 1) chemical, biological or nuclear weapons, or for the development, production, maintenance or storage of missiles for such weapons; 2) civil firearms, including spare parts or ammunition for such arms; 3) defense related products, or other material for military use or for law enforcement; 4) any applications that, alone or in combination with other goods, substances or organisms could cause serious harm to persons or goods and that can be used as a means of violence in an armed conflict or any similar violent situation.

The Products sold by Melexis are subject to the terms and conditions as specified in the Terms of Sale, which can be found at <https://www.melexis.com/en/legal/terms-and-conditions>.

This document supersedes and replaces all prior information regarding the Product(s) and/or previous versions of this document.

Melexis NV © - No part of this document may be reproduced without the prior written consent of Melexis. (2016)

ISO/TS 16949 and ISO14001 Certified