

MLX90614

Single and dual zone IR sensor in TO39
Datasheet

General description

Features & benefits

- Small size, low cost IR sensor
- Easy to integrate
- Industry standard four lead TO39 package
- Factory calibrated (reports temperature) in wide temperature range:
 - -40°C...+125°C for sensor temperature
 - -70°C...+380°C for object temperature
- High accuracy of 0.5°C in wide temperature range – 0°C...+50°C for both Ta and To
- High (medical) accuracy version
- Measurement resolution of 0.02°C
- SMBus compatible digital interface
- Customizable PWM output for continuous reading
- Single or dual zone version
- Available in 3.0V and 5.0V supply voltages
- Current consumption \approx 1.4mA
- Simple adaptation for an 8V...16V applications
- Sleep mode for reduced power consumption
- Operating temperature -40°C...+125°C
- Target temperature -70°C...+380°C
- Automotive grade

Applications examples

- High precision non-contact temperature measurements
- Microwave ovens
- Thermal Comfort sensor for Mobile Air Conditioning control system
- Intrusion / Movement detection
- Temperature sensing element for residential, commercial and industrial building air conditioning
- Windshield defogging
- Automotive blind angle detection
- Industrial temperature control of moving parts
- Temperature control in printers and copiers
- Home appliance with temperature control
- Healthcare
- Livestock monitor
- Movement detector
- Thermal relay / alert
- Body temperature measurement

Description

The MLX90614 is an Infra-Red thermometer for non-contact temperature measurements. Both the IR sensitive thermopile detector chip and the signal conditioning ASSP are integrated in the same TO-39 can.

Thanks to its low noise amplifier, 17-bit ADC and powerful DSP unit, a high accuracy and resolution of the thermometer is achieved.

The thermometer comes factory calibrated with a digital PWM and SMBus (System Management Bus) output.

As a standard, the 10-bit PWM is configured to continuously transmit the measured temperature in the range of -20...120°C, with an output resolution of 0.14°C.

The factory default POR setting is SMBus.

Available support & tools

- www.melexis.com/technical-inquiry



MLX90614

Single and dual zone IR sensor in TO39
Datasheet

Ordering information

Product code	Temperature	Package	Supply	TGC	FOV option	Packing
MLX90614ESF-ACC-000-TU	-40 to 85 °C	SF	Axx – 5.0V	xCx - ON	xxC – 35°	Tube
MLX90614ESF-BCC-000-TU	-40 to 85 °C	SF	Bxx – 3.0V	xCx - ON	xxC – 35°	Tube
MLX90614KSF-ACC-000-TU	-40 to 125 °C	SF	Axx – 5.0V	xCx - ON	xxC – 35°	Tube

Table 1 – Product codes (limited version listed out of many combinations)

NOTE: For more options please, refer to Table 20 at the end of the document

MLX90614KSF-ACC-000-TU

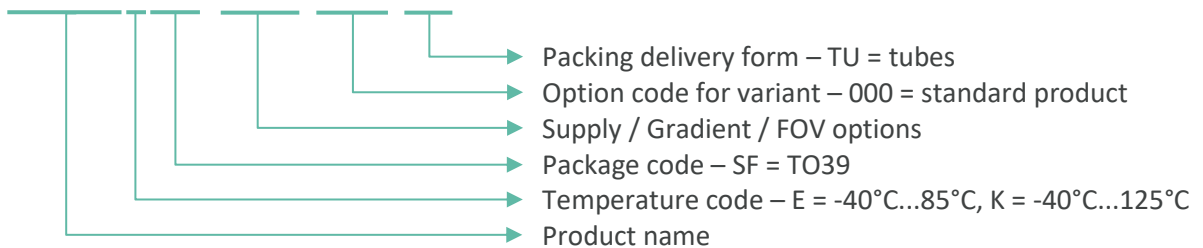

MLX90614

Single and dual zone IR sensor in TO39
Datasheet

CONTENTS

GENERAL DESCRIPTION	1
FEATURES & BENEFITS.....	1
APPLICATIONS EXAMPLES.....	1
DESCRIPTION.....	1
ORDERING INFORMATION	2
1 MLX90614 APPLICATION CONSIDERATIONS	5
2 PINS DESCRIPTION	6
3 CONDITIONS AND SPECIFICATIONS	7
3.1 ABSOLUTE MAXIMUM RATINGS (AMR).....	7
3.2 ELECTRICAL OPERATING CONDITIONS & SPECIFICATIONS.....	8
3.2.1 MLX90614Axx.....	8
3.2.2 MLX90614Bxx and MLX90614Dxx.....	9
4 FUNCTIONAL DESCRIPTION & INTERFACES	11
4.1 DETAILED DESCRIPTION.....	11
4.1.1 Block diagram.....	11
4.1.2 Signal processing principle.....	11
4.1.3 Block description.....	12
4.1.4 Communication protocol – SMBus.....	16
4.1.5 PWM (Pulse Width Modulation) mode.....	23
4.1.6 Switching between PWM / Thermal relay and SMBus.....	27
4.1.7 Thermal relay.....	28
4.1.8 Computation of ambient and object temperature.....	29
4.2 UNIQUE FEATURES.....	32
4.3 PERFORMANCE GRAPHS.....	33
4.3.1 Accuracy.....	33
4.3.2 Standard accuracy.....	33
4.3.3 Medical accuracy.....	35
4.3.4 Temperature reading dependence on VDD.....	35
4.3.5 Field of view (FOV).....	37
5 APPLICATION	41
5.1 RECOMMENDED APPLICATION DIAGRAM – SMBUS CONFIGURATION.....	41
5.2 MULTIPLE MLX90614xxx ON THE SMBUS.....	41
5.3 PWM OUTPUT OPERATION.....	42
5.4 THERMAL ALERT / THERMOSTAT.....	42
5.5 HIGH VOLTAGE OPERATION.....	43
5.6 CHANGING EMISSIVITY.....	43
5.7 GENERAL APPLICATION COMMENTS.....	43
5.8 FAQ.....	45
6 PACKAGE, IC HANDLING AND ASSEMBLY	47
6.1 PACKAGE INFORMATION.....	47
6.1.1 Package MLX90614xxA.....	47
6.1.2 Package MLX90614xCC.....	47
6.1.3 Package MLX90614xCF.....	48
6.1.4 Package MLX90614xCH.....	48
6.1.5 Package MLX90614xCl.....	49
6.1.6 Package MLX90614xCK.....	49
6.1.7 Package marking.....	50
6.2 STORAGE AND HANDLING OF ICs.....	50
6.3 ASSEMBLY OF TO PACKAGED ICs.....	50
6.4 ENVIRONMENT AND SUSTAINABILITY.....	51
6.5 PACKING INFORMATION.....	51
6.5.1 Packing method.....	51
6.5.2 Packing style.....	52

MLX90614

Single and dual zone IR sensor in TO39
Datasheet



7	GLOSSARY OF TERMS & REFERENCES	53
7.1	GLOSSARY	53
7.2	LIST OF TABLES	54
7.3	LIST OF FIGURES	55
7.4	REFERENCES	57
8	DISCLAIMER.....	58

MLX90614

Single and dual zone IR sensor in TO39
Datasheet



1 MLX90614 application considerations

The MLX90614 is factory calibrated in wide temperature ranges: -40°C ... 125°C for the ambient temperature and -70°C ... 380°C for the object temperature.

The measured value is the average temperature of all objects in the **Field Of View** of the sensor. The MLX90614 offers a standard accuracy of $\pm 0.5^{\circ}\text{C}$ around room temperatures. A special version for medical applications exists offering an accuracy of $\pm 0.2^{\circ}\text{C}$ in a limited temperature range around the human body temperature.

It is very important for the application designer to understand that these accuracies are **only guaranteed** and achievable when the sensor is in thermal equilibrium and under isothermal conditions (there are no temperature differences across the sensor package). The accuracy of the thermometer can be influenced by temperature differences in the package induced by causes like (among others): Hot electronics behind the sensor, heaters/coolers behind or beside the sensor or by a hot/cold object very close to the sensor that not only heats the sensing element in the thermometer but also the thermometer package.

This effect is especially relevant for thermometers with a small FOV like the xxl, xxF and xxK as the energy received by the sensor from the object is reduced. Therefore, Melexis has introduced the xCx version of the MLX90614. In these MLX90614xCx, the thermal gradients are measured internally and the measured temperature is compensated for them. In this way, the xCx version of the MLX90614 is much less sensitive to thermal gradients, but the effect is not totally compensated. It is therefore important to avoid the causes of thermal gradients as much as possible or to shield the sensor from them.

As a standard, the MLX90614 is calibrated for an object emissivity of 1. It can be easily customized by the customer for any other emissivity in the range 0.1...1.0 without the need of recalibration with a black body.

The 10-bit PWM is as a standard configured to transmit continuously the measured object temperature for an object temperature range of -20°C ... 120°C with an output resolution of 0.14°C . The PWM can be easily customized for virtually any range desired by the customer by changing the content of 2 EEPROM cells. This has no effect on the factory calibration of the device.

The PWM pin can also be configured to act as a thermal relay (input is T_o), thus allowing for an easy and cost effective implementation in thermostats or temperature (freezing / boiling) alert applications. The temperature threshold is user programmable. In a SMBus system this feature can act as a processor interrupt that can trigger reading all slaves on the bus and to determine the precise condition.

The thermometer is available in 2 supply voltage options: 5V compatible or 3V (battery) compatible. The 5V can be easily adapted to operate from a higher supply voltage (8...16V, for example) by use of few external components (refer to "High voltage operation" section for details).

An optical filter (long-wave pass) that cuts off the visible and near infra-red radiant flux is integrated in the package to provide ambient and sunlight immunity. The wavelength pass band of this optical filter is from $5.5\mu\text{m}$... $14\mu\text{m}$ (except for xCH and xCI type of devices which incorporate uncoated silicon lens).

MLX90614

Single and dual zone IR sensor in TO39
Datasheet

2 Pins description

Pin #	Name	I/O ⁽¹⁾	Description
1	SCL / Vz	I	SMBus serial clock, 5.7V zener is available for MLX90614Axx versions
2	SDA / PWM	I/O	SMBus serial data / PWM output
3	VDD	S	External supply
4	VSS	S	Negative supply (Ground)

Table 2 – TO39 package pins description

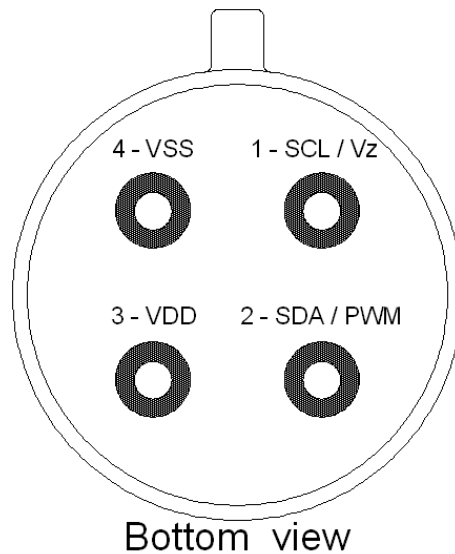

Figure 1 – MLX90614 overview and pin description

NOTE: for +12V (+8V...+16V) powered operation refer to the Application information section. For EMC and isothermal conditions reasons it is highly recommended not to use any electrical connection to the metal can except by the VSS pin.

With the SCL / Vz and PWM / SDA pins operated in 2-wire interface mode, the input Schmidt trigger function is automatically enabled.

¹ [S] Supply, [I] input, [O] output

MLX90614

Single and dual zone IR sensor in TO39
Datasheet

3 Conditions and specifications

3.1 Absolute Maximum Ratings (AMR)

(T_A=25°C, unless otherwise specified)

Parameter	Symbol	Min	Max	Unit	Condition
Supply voltage – Axx type	VDD		7	V	< 24 hours
Supply voltage – Bxx type	VDD		5	V	< 24 hours
SDA output (sink) current	I _{SDA_SINK}		100	mA	< 24 hours
Reverse voltage (each pin)	V _{REVERSE}		-0.4	V	< 24 hours
ESD voltage	V _{ESD-HBM}		± 2	kV	HBM (AEC-Q100-002), all pins
Storage temperature	T _{STG}	-40	125	°C	
Operating temperature – ESF type	T _O	-40	85	°C	Ambient temperature
Operating temperature – KSF type	T _O	-40	125	°C	Ambient temperature

Table 3 – Absolute Maximum Ratings

Exceeding the absolute maximum ratings may cause permanent damage.

Exposure to absolute maximum-rated conditions for extended periods may affect the device reliability.

MLX90614

Single and dual zone IR sensor in TO39
Datasheet



3.2 Electrical operating conditions & specifications

3.2.1 MLX90614Axx

Unless otherwise specified, the electrical specifications are valid for a $T_A = 25^\circ\text{C}$, and a supply voltage = 5.0V

Parameter	Symbol	Min.	Typ.	Max.	Unit	Condition
Supply voltage	V_{DD}	4.5	5.0	5.5	V	$\pm 50\text{mV}$
Supply voltage rising	$V_{DD\text{-rising}}$	0		20	ms	Ensure POR

Table 4 – Electrical operating conditions

Parameter	Symbol	Min.	Typ.	Max.	Unit	Condition
Supply Current	I_{DD}		1.3	2.5	mA	
Zener voltage	V_Z	5.5	5.7	5.9	V	$I_Z = 75\text{...}1000\mu\text{A}$, $T_a = \text{room}$
Zener voltage	$V_Z (T_A)$	5.15	5.7	6.24	V	$I_Z = 75\text{...}1000\mu\text{A}$, all T_a
POR level up	V_{POR_UP}	1.4	1.75	1.95	V	VDD raising (all T_a)
POR level down	V_{POR_DOWN}	1.3	1.7	1.9	V	VDD falling (all T_a)
POR hysteresis	V_{POR_HYS}	0.08	0.1	1.15	V	all T_a
Input high voltage (SDA, SCL)	V_{IN_H}	3			V	over T_a and V_{DD}
Input low voltage (SDA, SCL)	V_{IN_L}			0.6	V	over T_a and V_{DD}
Output high voltage	V_{OUT_H}	$V_{DD} - 0.2$			V	$I_{SOURCE} = 2\text{mA}$
Output low voltage	V_{OUT_L}			$V_{SS} + 0.2$	V	$I_{SINK} = 2\text{mA}$
Output drive current	I_{DRIVE}		7		mA	$V_{OUT_H} = V_{DD} - 0.8\text{V}$
Output sink current	I_{SINK}		13.5		mA	$V_{OUT_L} = 0.8\text{V}$
SDA output low voltage	V_{OL}			0.2	V	$I_{SINK} = 2\text{mA}$ (over T_a and V_{DD})
SCL leakage	I_{SCL_LEAK}			30	μA	$V_{SCL} = 4.0\text{V}$, $T_a = 85^\circ\text{C}$ (zener)
SDA leakage	I_{SDA_LEAK}			0.4	μA	$V_{SDA} = 5.0\text{V}$, $T_a = 85^\circ\text{C}$
SDA capacitance	C_{SDA}			10	pF	
SCL capacitance	C_{SCL}			10	pF	
SMBus clock frequency	F_{SMBus}	10		100	kHz	
To output resolution	T_{O_RES}		0.02		$^\circ\text{C}$	SMBus mode
To output resolution	T_{O_RES}	0.44		0.02	$^\circ\text{C}$	PWM mode
PWM resolution	PWM_{RES}		10		bit	
PWM output period	PWM_{T_DEF}		1.024		ms	RC oscillator dependent
PWM period stability	$dPWM_T$	-10		+10	%	(over T_a and V_{DD})
Output valid (results in RAM)	T_{valid}		250		ms	After POR
Slave address	SA		5A		hex	
Wake up request	t_{WAKE}	33			ms	SDA low
SMBus request	t_{REQ}	1.44			ms	SCL low
Timeout, low	$T_{TIMEOUT_L}$	27		33	ms	SCL low
Acknowledge setup time	$T_{SUAC} (MD)$			1.5	μs	8-th SCL falling edge, Master
Acknowledge hold time	$T_{HDAC} (MD)$			1.5	μs	9-th SCL falling edge, Master
Acknowledge setup time	$T_{SUAC} (SD)$			2.5	μs	8-th SCL falling edge, Slave
Acknowledge hold time	$T_{HDAC} (SD)$			1.5	μs	9-th SCL falling edge, Slave
EEPROM data retention		10			Years	$T_a = 85^\circ\text{C}$
EEPROM write / erase cycles		100,000			cycles	$T_a = 25^\circ\text{C}$
EEPROM write / erase cycles		10,00			cycles	$T_a = 125^\circ\text{C}$
Erase cell time (EEPROM)	T_{ERASE}		5		ms	
Write cell time (EEPROM)	T_{WRITE}		5		ms	

Table 5 – Electrical specifications Axx version

MLX90614

Single and dual zone IR sensor in TO39
Datasheet



3.2.2 MLX90614Bxx and MLX90614Dxx

Unless otherwise specified, the electrical specifications are valid for a $T_A = 25^\circ\text{C}$, and a supply voltage = 3.0V

Parameter	Symbol	Min.	Typ.	Max.	Unit	Condition
Supply voltage	V_{DD}	2.6	3.0	3.6	V	$\pm 50\text{mV}$
Supply voltage rising	$V_{DD\text{-rising}}$	0		20	ms	Ensure POR

Table 6 – Electrical operating conditions

Parameter	Symbol	Min.	Typ.	Max.	Unit	Condition
Supply Current	I_{DD}		1.3	2.5	mA	
Sleep current	I_{SLEEP}		2	6	μA	over T_a and V_{DD}
POR level up	V_{POR_UP}	1.4	1.75	1.95	V	VDD raising (all T_a)
POR level down	V_{POR_DOWN}	1.3	1.7	1.9	V	VDD falling (all T_a)
POR hysteresis	V_{POR_HYS}	0.08	0.1	1.15	V	all T_a
Input high voltage (SDA, SCL)	V_{IN_H}	$V_{DD} - 0.1$			V	over T_a and V_{DD}
Input low voltage (SDA, SCL)	V_{IN_L}			0.6	V	over T_a and V_{DD}
Output high voltage	V_{OUT_H}	$V_{DD} - 0.25$			V	$I_{SOURCE} = 2\text{mA}$
Output low voltage	V_{OUT_L}			$V_{SS} + 0.25$	V	$I_{SINK} = 2\text{mA}$
Output drive current	I_{DRIVE}		4.5		mA	$V_{OUT_H} = V_{DD} - 0.8\text{V}$
Output sink current	I_{SINK}		11		mA	$V_{OUT_L} = 0.8\text{V}$
SDA output low voltage	V_{OL}			0.2	V	$I_{SINK}=2\text{mA}$ (over T_a and V_{DD})
SCL leakage	I_{SCL_LEAK}			20	μA	$V_{SCL}=3.0\text{V}$, $T_a=85^\circ\text{C}$
SDA leakage	I_{SDA_LEAK}			0.25	μA	$V_{SDA}=3.0\text{V}$, $T_a=85^\circ\text{C}$
SDA capacitance	C_{SDA}			10	pF	
SCL capacitance	C_{SCL}			10	pF	
SMBus clock frequency	F_{SMBUS}	10		100	kHz	
To output resolution	T_{O_RES}		0.02		$^\circ\text{C}$	SMBus mode
To output resolution	T_{O_RES}	0.44		0.02	$^\circ\text{C}$	PWM mode
PWM resolution	PWM_{RES}		10		bit	
PWM output period	PWM_{T_DEF}		1.024		ms	RC oscillator dependent
PWM period stability	$dPWM_T$	-10		+10	%	(over T_a and V_{DD})
Output valid (results in RAM)	T_{valid}		250		ms	After POR
Slave address	SA		5A		hex	
Wake up request	t_{WAKE}	33			ms	SDA low
SMBus request	t_{REQ}	1.44			ms	SCL low
Timeout, low	$T_{TIMEOUT_L}$	27		33	ms	SCL low
Acknowledge setup time	$T_{SUAC} (MD)$			1.5	μs	8-th SCL falling edge, Master
Acknowledge hold time	$T_{HDAC} (MD)$			1.5	μs	9-th SCL falling edge, Master
Acknowledge setup time	$T_{SUAC} (SD)$			2.5	μs	8-th SCL falling edge, Slave
Acknowledge hold time	$T_{HDAC} (SD)$			1.5	μs	9-th SCL falling edge, Slave
EEPROM data retention		10			Years	$T_a=85^\circ\text{C}$
EEPROM write / erase cycles		100,000			cycles	$T_a=25^\circ\text{C}$
EEPROM write / erase cycles		10,00			cycles	$T_a=125^\circ\text{C}$
Erase cell time (EEPROM)	T_{ERASE}		5		ms	
Write cell time (EEPROM)	T_{WRITE}		5		ms	

Table 7 – Electrical specification – Bxx and Dxx versions

NOTE 1: All the communication and refresh rate timings are given for the nominal calibrated HFO frequency and will vary with this frequency's variations.

NOTE 2: With large capacitive load lower PWM frequency is recommended. Thermal relay output (when configured) has the PWM DC specification and can be programmed as push-pull, or NMOS open drain. PWM

MLX90614

Single and dual zone IR sensor in TO39
Datasheet



is free-running, power-up factory default is SMBus, refer to section 4.1.6, “Switching between PWM and SMBus communication” for more details.

NOTE 3: For SMBus compatible interface on 12V application refer to Application information section. SMBus compatible interface is described in details in the SMBus detailed description section. Maximum number of MLX90614 devices on one bus is 127, higher pull-up currents are recommended for higher number of devices, faster bus data transfer rates, and increased reactive loading of the bus.

NOTE 4: MLX90614 is always a slave device on the bus. MLX90614 can work in both low-power and high-power SMBus communication.

NOTE 5: All voltages are referred to the Vss (ground) unless otherwise noted.

NOTE 6: Sleep mode is not available on the 5V version (MLX90614Axx).

4 Functional description & interfaces

4.1 Detailed description

4.1.1 Block diagram

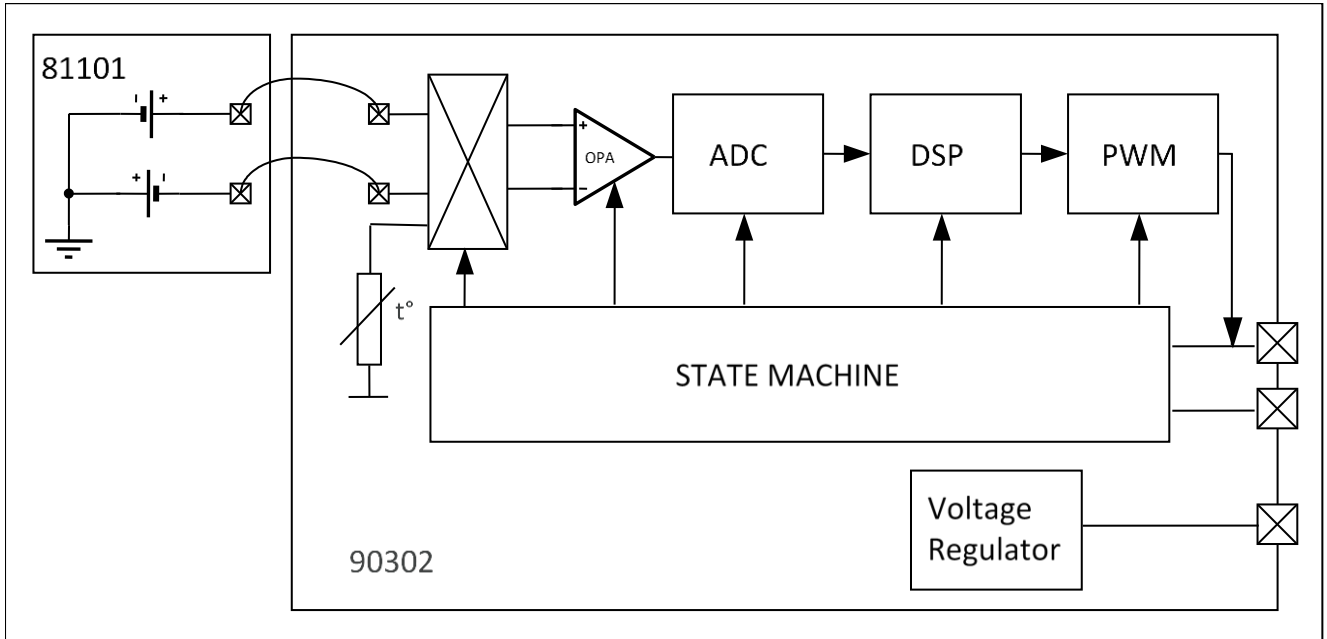

Figure 2 – Block diagram

4.1.2 Signal processing principle

The operation of the MLX90614 is controlled by an internal state machine, which controls the measurements and calculations of the object and ambient temperatures and does the post-processing of the temperatures to output them through the PWM output or the SMBus compatible interface.

The ASSP supports 2 IR sensors (second one not implemented in the MLX90614xAx). The output of the IR sensors is amplified by a low noise low offset chopper amplifier with programmable gain, converted by a Sigma Delta modulator to a single bit stream and fed to a powerful DSP for further processing. The signal is treated by programmable (by means of EEPROM content) FIR and IIR low pass filters for further reduction of the band width of the input signal to achieve the desired noise performance and refresh rate. The output of the IIR filter is the measurement result and is available in the internal RAM, where 3 different cells are available: One for the on-board temperature sensor and 2 for the IR sensors.

Based on results of the above measurements, the corresponding ambient temperature T_a and object temperatures T_o are calculated. Both calculated temperatures have a resolution of 0.01°C . The data for T_a and T_o can be read in two ways: Reading RAM cells dedicated for this purpose via the 2-wire interface (0.02°C resolution, fixed ranges), or through the PWM digital output (10 bit resolution, user configurable range).

In the last step of the measurement cycle, the measured T_a and T_o are rescaled to the desired output resolution of the PWM) and the recalculated data is loaded in the registers of the PWM state machine, which creates a constant frequency with a duty cycle representing the measured data.

MLX90614

Single and dual zone IR sensor in TO39
Datasheet



4.1.3 Block description

4.1.3.1 Amplifier

A low noise, low offset amplifier with programmable gain is used for amplifying the IR sensor voltage. By carefully designing the input modulator and balanced input impedance, the max offset of the system is 0.5µV.

4.1.3.2 Supply regulator and POR

The module can operate from 3 different supplies:

VDD = 5V → MLX90614Axx

VDD = 3V → MLX90614Bxx (battery or regulated supply)

VDD = 8V...16V → MLX90614Axx few external components are necessary please refer to “Applications information” section for information about adapting higher voltage supplies.

The **Power On Reset (POR)** is connected to Vdd supply. The on-chip POR circuit provides an active (high) level of the POR signal when the Vdd voltage rises above approximately 0.5V and holds the entire MLX90614 in reset until the Vdd is higher than the specified POR threshold V_{POR} . During the time POR is active, the POR signal is available as an open drain at the PWM/SDA pin. After the MLX90614 exits the POR condition, the function programmed in EEPROM takes precedence for that pin.

4.1.3.3 EEPROM

A limited number of addresses in the EEPROM memory can be changed by the customer. The whole EEPROM can be read through the SMBus interface.

EEPROM (32X16)		
Name	Address	Write access
To _{max}	0x00	Yes
To _{min}	0x01	Yes
PWMCTRL	0x02	Yes
Ta range	0x03	Yes
Emissivity	0x04	Yes
Config Register1	0x05	Yes
Melexis reserved	0x06	No
...
Melexis reserved	0x0D	No
SMBus address (LSB only)	0x0E	Yes
Melexis reserved	0x0F	Yes
Melexis reserved	0x10	No
...
Melexis reserved	0x18	No
Melexis reserved	0x19	Yes
Melexis reserved	0x1A	No
Melexis reserved	0x1B	No
ID number	0x1C	No
ID number	0x1D	No
ID number	0x1E	No
ID number	0x1F	No

Table 8 – EEPROM table – size 32x16

MLX90614

Single and dual zone IR sensor in TO39
 Datasheet



The addresses To_{max} , To_{min} and Ta range are for customer defined object and ambient temperature ranges. For details see section 4.1.5.1 below in this document

The address **Emissivity** contains the object emissivity (factory default 1.0 = 0xFFFF), 16 bit.

$$\text{Emissivity} = \text{dec2hex}[\text{round}(65535 \times \epsilon)]$$

Where $\text{dec2hex}[\text{round}(X)]$ represents decimal to hexadecimal conversion with round-off to nearest value (not truncated). In this case the physical emissivity values are $\epsilon = 0.1...1.0$.

Erase (write 0) must take place before the write of the desired data is done.

B15	B14	B13	B12	B11	B10	B9	B8	B7	B6	B5	B4	B3	B2	B1	B0	Configuration register 1
													0	0	0	IIR filter (50%) - a1=0.5, b=0.5
													0	0	1	IIR filter (25%) - a1=0.25, b=0.75
													0	1	0	IIR filter (17%) - a1=0.166(6), b=0.833(3)
													0	1	1	IIR filter (13%) - a1=125, b=0.875
													1	0	0	IIR filter (100%) - a1=1, b=0
													1	0	1	IIR filter (80%) - a1=0.8, b=0.2
													1	1	0	IIR filter (67%) - a1=0.666(6), b=0.333(3)
													1	1	1	IIR filter (57%) - a1=0.571, b=0.428
													0			Repeat sensor selftest - "OFF"
													1			Repeat sensor selftest - "ON"
													0	0		PWM mode - Ta, Tobj1
													0	1		PWM mode - Ta, Tobj2
													1	0		PWM mode - Tobj2 only
													1	1		PWM mode - Tobj1, Tobj2
													0			Single IR sensor
													1			Dual IR sensor
													0			Ks sign - positive
													1			Ks sign - negative
					0	0	0									FIR filter = 8 - not recommended
					0	0	1									FIR filter = 16 - not recommended
					0	1	0									FIR filter = 32 - not recommended
					0	1	1									FIR filter = 64 - not recommended
					1	0	0									FIR filter = 128 - single sensor Refresh Rate = 36ms, dual sensor Refresh rate = 53ms
					1	0	1									FIR filter = 256 - single sensor Refresh Rate = 44ms, dual sensor Refresh Rate = 53ms
					1	1	0									FIR filter = 512 - single sensor Refresh Rate = 60ms, dual sensor RR = 90ms
					1	1	1									FIR filter = 1024 - single sensor Refresh Rate = 93ms, dual sensor RR = 138ms
					0	0	0									GAIN = 1 - Amplifier bypassed
					0	0	1									GAIN = 3
					0	1	0									GAIN = 6
					0	1	1									GAIN = 12.5
					1	0	0									GAIN = 25
					1	0	1									GAIN = 50
					1	1	0									GAIN = 100
					1	1	1									GAIN = 100
					0											Kt2 sign - positive
					1											Kt2 sign - negative
					0											Sensor selftest - ENABLED
					1											Sensor selftest - DISABLED

Table 9 – Configuration register 1

NOTE: The following bits / registers should not be altered (except with special tools – contact Melexis for such tools availability) in order to keep the factory calibration relevant:

Emissivity [15...0]; Config Register1 [14...11;7;3]; addresses 0x0F and 0x19.

PWM period configuration: Period in extended PWM mode is twice the period in single PWM mode.

In single PWM mode, the period is $T = 1.024 * P$ [ms], where P is the number, written in bits 15...9 PWMCTRL. Maximum period is then 131.072 ms for single and 262.144 ms for extended. These values are typical and depend on the on-chip RC oscillator absolute value. The duty cycle must be calculated instead of working only with the high time only in order to avoid errors from the period absolute value deviations.

The address **PWMCTRL** consists of control bits for configuring the PWM/SDA pin as follows:

MLX90614

Single and dual zone IR sensor in TO39
 Datasheet



B15	B14	B13	B12	B11	B10	B9	B8	B7	B6	B5	B4	B3	B2	B1	B0	PWM control bit meaning
															0	PWM mode - EXTENDED
															1	PWM mode - SINGLE
															0	PWM - DISABLED (EN_PWM)
															1	PWM - ENABLED (EN_PWM)
															0	SDA output - OPEN DRAIN (PPODB)
															1	SDA output - PUSH-PULL (PPODB)
															0	Data mode - PWM (TRPWMB)
															1	Data mode - THERMAL RELAY (TRPWMB)
																PWM repetition number 0...62 step 2
																PWM period 1.0248ms (SINGLE mode) or 2.048*ms (EXTENDED mode) multiplied by the number in bit15...bit9 (128 in case the number I 0)

Table 10 – PWM control bits

* Values are valid for nominal HFO frequency

Check www.melexis.com for latest application notes with details on EEPROM settings.

On-chip filtering and settling time:

The MLX90614 features configurable on-chip digital FIR and IIR filters.

FIR filter: This filter determines how many samples are averaged before the output register is refreshed. Please note that the refresh rate depends on how many IR channels the device is processing (1 – single zone device without thermal gradient compensation or 2 – dual zone or devices with thermal gradient compensation). The FIR filter has a straightforward effect on the noise (4 times decrease of the filter strength results in an increase of 2 times the noise reduction and vice versa).

IIR filter: The IIR filter provides an additional, spike limiting feature. Spike limit defines the level of magnitude to which the spike would be limited for each reading – for example, 25% denotes that if a 20°C temperature delta spike is measured the temperature reading by the MLX90614 will spike only 5°C on the first reading, then for the second reading the delta is already 15°C thus the MLX90614 will return 25% of that delta i.e. 3.75+5=8.75°C and so on until the output approaches the target value.

Output settling time = f (FIR, IIR), ms									
No of IR sensors	FIR \ IIR	IIR=100%	IIR=80%	IIR=67%	IIR=57%	IIR=50%	IIR=25%	IIR=17%	IIR=13%
Single (xAx)	FIR=128	36	140	192	244	270	660	998	1360
	FIR=256	44	180	250	317	352	864	1310	1788
	FIR=512	60	263	364	465	516	1274	1932	2640
	FIR=1024	93	427	593	760	843	2093	3176	4343
Dual (xCx, xBx)	FIR=128	52	223	308	394	436	1075	1630	2226
	FIR=256	65	284	394	504	560	1382	2097	2866
	FIR=512	89	407	566	725	804	2000	3030	4144
	FIR=1024	138	652	910	1168	1300	3226	4900	6700

Table 11 – output settling time as a function of the filter settings

NOTE 1: The values under IIR=100% (highlighted) correspond to the device refresh rate determined only by the FIR filter settings

NOTE 2: No IIR filter is applied on the PWM signal

The onboard filters allow customization for speed or noise. Factory default configurations, the typical settling time and the typical noise for the MLX90614 family are given below.

MLX90614

Single and dual zone IR sensor in TO39
Datasheet

Device	Settling time, sec	Typical noise, °C RMS	Spike limit
MLX90614AAA, BAA, DAA	0.10	0.05	1.00
MLX90614ABA, BBA	0.14	0.07	1.00
MLX90614ACC, BCC, DCC	0.14	0.18	1.00
MLX90614ACF, BCF	1.33	0.10	0.50
MLX90614DCH, DCI, BCH, BCI	0.65	0.10	0.80
MLX90614ACK, BCK	1.33	0.30	0.50

Table 12 – factory default IIR and FIR configuration, settling time and typical noise

Details on the filters are given in the application note “Understanding MLX90614 on-chip digital signal filters” available from www.melexis.com.

The evaluation board, EVB90614 supported by PC SW allows easy configuration of the filters, while not requiring in-depth understanding of the EEPROM.

FIR settings	Refresh rate, sec		Settling time, sec		IIR settings	Spike limit
	90614xAx	90614xBx	90614xAx	90614xBx		
000...011	Not recommended					
100	0.036	0.052	0.04	0.06	100	100%
101	0.044	0.065	0.05	0.07	100	100%
110	0.060	0.090	0.06	0.10	100	100%
111	0.094	0.138	0.10	0.14	100	100%
100	0.036	0.052	0.12	0.20	101	80%
101	0.044	0.065	0.16	0.24	101	80%
110	0.060	0.090	0.22	0.34	101	80%
111	0.094	0.138	0.35	0.54	101	80%
100	0.036	0.052	0.24	0.38	110	66.7%
101	0.044	0.065	0.30	0.48	110	66.7%
110	0.060	0.090	0.43	0.67	110	66.7%
111	0.094	0.138	0.70	1.10	110	66.7%
100	0.036	0.052	0.26	0.42	111	57%
101	0.044	0.065	0.34	0.53	111	57%
110	0.060	0.090	0.48	0.75	111	57%
111	0.094	0.138	0.78	1.20	111	57%
100	0.036	0.052	0.30	0.47	000	50%
101	0.044	0.065	0.37	0.60	000	50%
110	0.060	0.090	0.54	0.84	000	50%
111	0.094	0.138	0.86	1.33	000	50%
100	0.036	0.052	0.70	1.10	001	25%
101	0.044	0.065	0.88	1.40	001	25%
110	0.060	0.090	1.30	2.00	001	25%
111	0.094	0.138	2.00	3.20	001	25%
100	0.036	0.052	1.10	1.80	010	16.7%
101	0.044	0.065	1.40	2.20	010	16.7%
110	0.060	0.090	2.00	3.20	010	16.7%
111	0.094	0.138	3.30	5.00	010	16.7%
100	0.036	0.052	1.50	2.40	011	12.50%
101	0.044	0.065	1.90	3.00	011	12.50%
110	0.060	0.090	2.80	4.30	011	12.50%
111	0.094	0.138	4.50	7.00	011	12.50%

Table 13 – FIR and IIR settings

NOTE: Refresh rate and Settling time are in seconds and depend on internal oscillator absolute value. 100% spike limit appears with the IIR filter bypassed, and there is no spike limitation.

MLX90614

Single and dual zone IR sensor in TO39
Datasheet



4.1.3.3.1 EEPROM write sequence

When an EEPROM cell content is to be changed, Melexis recommends following procedure:

1. Power ON the device
2. Write 0x0000 into the cell of interest (effectively erasing the cell)
3. Wait at least 5ms (10ms to be on the safe side)
4. Read back and compare if the write was successful
5. Write the new value
6. Wait at least 5ms (10ms to be on the safe side)
7. Read back and compare if the write was successful
8. Power OFF (to be sure that when power up next time the changes will take place)

4.1.3.4 RAM

It is not possible to write into the RAM memory. It can only be read and only a limited number of RAM registers are of interest to the customer.

RAM (32 x16)		
Name	Address	Read access
Melexis reserved	0x00	Yes
...
Melexis reserved	0x03	Yes
Raw data IR channel 1	0x04	Yes
Raw data IR channel 2	0x05	Yes
TA	0x06	Yes
TOBJ1	0x07	Yes
TOBJ2	0x08	Yes
Melexis reserved	0x09	Yes
...
Melexis reserved	0x1F	Yes

Table 14 – RAM table – size 32x16

4.1.4 Communication protocol – SMBus

The device uses SMBus protocol with clock frequency within 10kHz...100kHz range, and can only act as a slave on the bus. The slave address is 7-bit programmable. This allows assigning any of the 127 different slave addresses to the device. Slave address 0x00, is a general call address. Both pins dedicated to the SMBus communication have the following features:

- SCL – digital input only, used as the clock for SMBus compatible communication. This pin has the auxiliary function for building an external voltage regulator. When the external voltage regulator is used, the 2-wire protocol is available only if the power supply regulator is overdriven.
- PWM/SDA – Digital input / output, used for both the PWM output of the measured object temperature(s) or the digital input / output for the SMBus. In PWM mode the pin can be programmed in EEPROM to operate as Push / Pull or open drain NMOS (open drain NMOS is factory default). In SMBus mode SDA is forced to open drain NMOS I/O, push-pull selection bit defines the driver output configuration while in PWM / Thermal relay operation.

MLX90614

Single and dual zone IR sensor in TO39
Datasheet



4.1.4.1 Functional description

The SMBus interface is a 2-wire protocol, allowing communication between the Master Device (MD) and one or more Slave Devices (SD). In the system only one master can be presented at any given time [1]. The MLX90614 can only be used as a slave device.

Generally, the MD initiates the start of data transfer by selecting a SD through the Slave Address (SA).

The MD has read access to the RAM and EEPROM and write access to 9 EEPROM cells (at addresses 0x00, 0x01, 0x02, 0x03, 0x04, 0x05 *, 0x0E, 0x0F, 0x19). If the access to the MLX90614 is a read operation it will respond with 16 data bits and 8-bit PEC only if its own slave address, programmed in the internal EEPROM matches to the SA, sent by the master. The SA feature allows connecting up to 127 devices (SA=0x00...0x07F) with only 2 wires, unless the system has some of the specific features described in paragraph 5.2 of reference [1]. In order to provide access to any device or to assign an address to a SD before it is connected to the bus system, the communication must start with zero SA followed by low R/W⁻ bit. When this command is sent from the MD, the MLX90614 will always respond and will ignore the internal chip code information.

Special care must be taken not to put two MLX90614 devices with the same SA on the same bus as MLX90614 does not support ARP [1].

The MD can force the MLX90614 into low consumption mode “sleep mode” (3V version only).

Read flags like “EEBUSY” (1 – EEPROM is busy with executing the previous write/erase), “EE_DEAD” (1 – there is a fatal EEPROM error and this chip is not functional **).

NOTE *: This address is readable and writable. Bit 3 should not be altered as this will cancel the factory calibration.

NOTE **: EEPROM error signaling is implemented in automotive grade parts only.

4.1.4.2 Differences with the standard SMBus specification (reference [1])

There are eleven command protocols for the standard SMBus interface. The MLX90614 supports only two of them.

Not supported commands are:

- Quick Command
- Byte commands - Sent Byte, Receive Byte, Write Byte and Read Byte
- Process Call
- Block commands – Block Write and Write-Block Read Process Call

Supported commands are:

- Read Word
- Write Word

4.1.4.3 Low level description

The PWM / SDA pin of MLX90614 can operate also as PWM output, depending on the EEPROM settings. If PWM is enabled, after POR the PWM / SDA pin is directly configured as PWM output. Even if the device is in PWM mode SMBus communication may be restored by a special command. That is why both modes are treated separately.

4.1.4.3.1 SMBus Protocol

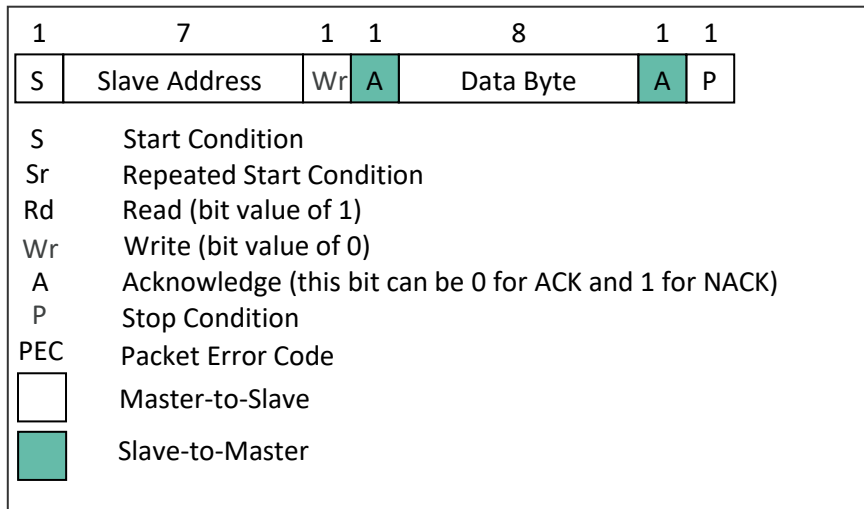

Figure 3 – SMBus packed element key

After every received 8 bits the SD should issue an ACK or NACK. When a MD initiates communication, it first sends the address of the slave and only the SD which recognizes the address will ACK, the rest will remain silent. In case the SD NACKs one of the bytes, the MD should stop the communication and repeat the message. A NACK could be received after the PEC. This means that there is an error in the received message and the MD should try sending the message again. The PEC calculation includes all bits except the START, REPEATED START, STOP, ACK, and NACK bits. The PEC is a CRC-8 with polynomial X^8+X^2+X+1 . The Most Significant Bit of every Byte is transferred first.

4.1.4.3.2 Start / Stop and repeated Start conditions

Each communication session is initiated by a START condition and ends with a STOP condition. A START condition is generated by a 'HIGH' to 'LOW' transition of the SDA while a STOP is generated by a 'LOW' to 'HIGH' transition of the SDA. Both changes must be done while the SCL is 'HIGH'. In case of read operation, special care **must** be taken in order to have properly generated repeated START condition ('HIGH' to 'LOW' transition of the SDA while SCL is "HIGH"). Write command does **NOT** require repeated START.

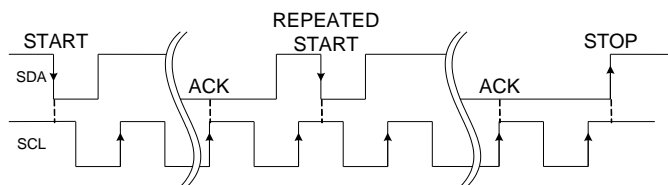

Figure 4 – START, Repeated START and STOP condition in read command only

NOTE: The controller **must** generate a STOP condition to abort the transfer regardless if the communication is successful (ACK received) or not (NACK received).

4.1.4.3.3 Device addressing

The master is addressing the slave device by sending a 7-bit slave address after the START condition. The seven MSb are dedicated for the address and the LSb is the Read/Write (R/W) bit. This bit indicates the direction of the transfer:

- Read (HIGH) means that the master will read the data from the slave
- Write (LOW) means that the master will send data to the slave

MLX90614

Single and dual zone IR sensor in TO39
Datasheet

4.1.4.3.4 Acknowledge

During the 9th clock following every byte transfer, the transmitter releases the SDA line. The receiver acknowledges (ACK) receiving the byte by pulling SDA line to 'LOW' or does not acknowledge (NACK) by letting the SDA 'HIGH'.

4.1.4.3.5 Bit transfer

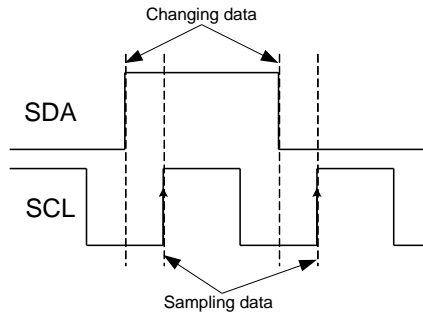

Figure 5 – Recommended timing on SMBus

The data on PWM / SDA must be changed when SCL is low (min 300ns after the falling edge of SCL). The data is fetched by both MD and SDs on the rising edge of the SCL. The recommended timing for changing data is in the middle of the period when the SCL is low.

4.1.4.3.6 Commands

Both RAM and EEPROM are 32x16 in size and user accessible for reading. If the RAM is read, the values are divided by two, due to a sign bit in RAM (for example, T₀₁ - RAM address 0x07 will sweep between 0x27AD to 0x7FFF as the object temperature changes from -70.01°C...+382.19°C). The MSb read from RAM is an error flag (active high) for the linearized temperatures (T₀₁, T₀₂ and T_a). The MSb for the raw data (e.g. IR sensor1 data) is a sign bit (sign and magnitude format). A write of 0x0000 must be done prior to writing in EEPROM in order to erase the EEPROM cell content. Refer to EEPROM detailed description for factory calibration EEPROM locations that need to be kept unaltered.

Opcode	Command
000x xxxx *	RAM access
001x xxxx *	EEPROM access
1111 0000 **	Read flags
1111 1111	Enter SLEEP mode

Table 15 – SMBus commands

Note*: The xxxxx represent the 5 LSBits of the memory map address to be read / written.

Note**: Behaves like a read command. The MLX90614 returns PEC after 16 bits of data of which only 4 are meaningful and if the MD wants it, it can stop the communication after the first byte. The difference between read and read flags is that the latter does not have a repeated start bit.

For details and examples for SMBus communication with the MLX90614 check the www.melexis.com

MLX90614

Single and dual zone IR sensor in TO39
Datasheet

4.1.4.3.7 Read word command

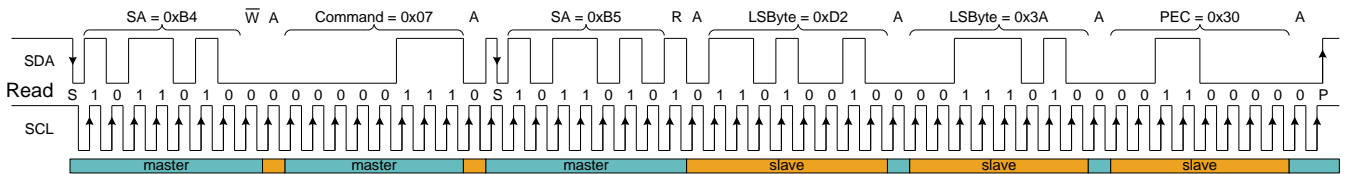

Figure 6 – SMBus read word (default SA = 0x5A, read RAM = 0x07, result = 0x3AD2, PEC = 0x30)

4.1.4.3.8 Write word command

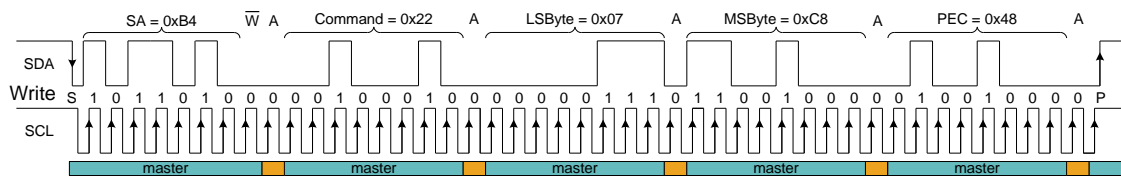

Figure 7 – SMBus write word (default SA = 0x5A, write EEPROM = 0x02, data = 0xC807, PEC = 0x48)

4.1.4.3.9 Go to sleep command

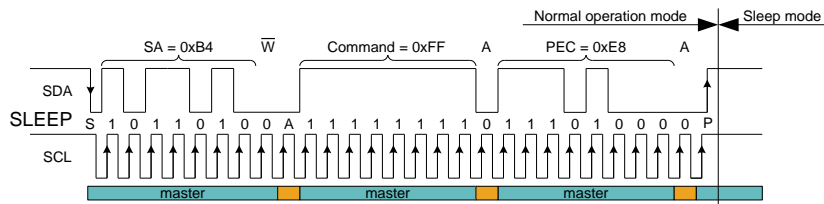

Figure 8 – Go to sleep mode command format (default SA = 0x5A, command = 0xFF, PEC = 0xE8)

4.1.4.3.10 Read flags command

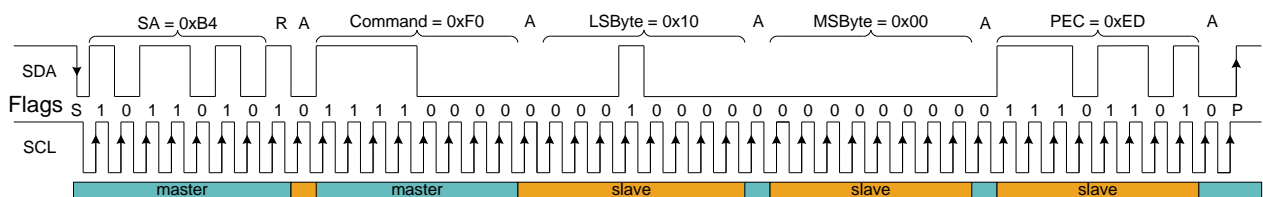

Figure 9 – Read flags command format (default SA = 0x5A, typical flags data = 0x0010, PEC = 0xED)

B15	B14	B13	B12	B11	B10	B9	B8	B7	B6	B5	B4	B3	B2	B1	B0	Flags
																Always "0"
																Not implemented
																0 INIT - POR initialization routing ongoing
																1 INIT - POR initialization routing completed
																0 EE_DEAD - EEPROM OK
																1 EE_DEAD - double error detected
																Not implemented
																0 EEPROM not busy
																1 EEPROM busy - write / erase EEPROM access still in progress
																Always "0"

Table 16 – Flags

MLX90614

Single and dual zone IR sensor in TO39
Datasheet

4.1.4.3.11 Exit from sleep mode (Wake Up Request)

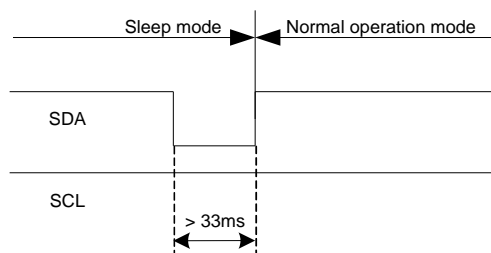

Figure 10 – Exit sleep mode (Wake Up Request)

After waking up the first data is available after 0.25 seconds (typ). On-chip IIR filter is skipped for the very first measurement. All measurements afterwards pass the embedded digital filtering as configured in EEPROM. Details on embedded filtering are available in application note “Understanding MLX90614 on-chip digital signal filters”, available from www.melexis.com

4.1.4.3.12 Timing specification

The MLX90614 meets all the timing specifications of the SMBus [1]. The maximum frequency of the MLX90614 SMBus is 100 KHz and the minimum is 10 KHz.

The specific timings in MLX90614’s SMBus are:

SMBus Request (t_{REQ}) is the time that the SCL should be forced low in order to switch MLX90614 from PWM mode to SMBus mode – at least 1.44ms;

Timeout L is the maximum allowed time for SCL to be low during communication. After this time the MLX90614 will reset its communication block and will be ready for new communication – not more than 27ms;

$T_{suac}(SD)$ is the time after the eighth falling edge of SCL that MLX90614 will force PWM / SDA low to acknowledge the last received byte – not more than 2.5 μ s.

$T_{hdac}(SD)$ is the time after the ninth falling edge of SCL that MLX90614 will release the PWM / SDA (so the MD can continue with the communication) – not more than 1.5 μ s.

$T_{suac}(MD)$ is the time after the eighth falling edge of SCL that MLX90614 will release PWM / SDA (so that the MD can acknowledge the last received byte) – not more than 1,5 μ s.

$T_{hdac}(MD)$ is the time after the ninth falling edge of SCL that MLX90614 will take control of the PWM / SDA (so it can continue with the next byte to transmit) – not more than 1.5 μ s.

MLX90614

Single and dual zone IR sensor in TO39
 Datasheet

The indexes MD and SD for the latest timings are used – MD when the master device is making acknowledge; SD when the slave device is making acknowledge. For other timings see [1].

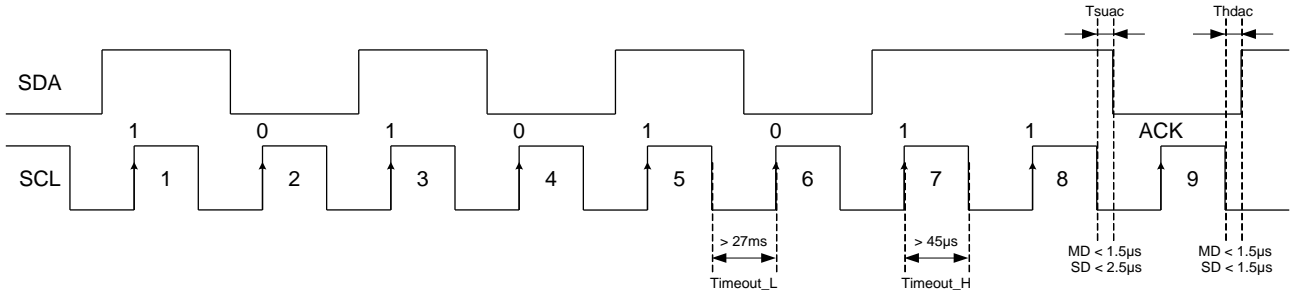

Figure 11 – SMBus timing specification and definition

4.1.4.3.13 MLX90614 SMBus specific remarks

The auxiliary functions of the SCL pin (Zener diode) add undershoot to the clock pulse (5V devices only) as shown in the picture below (see Figure 12). This undershoot is caused by the transient response of the on-chip synthesized Zener diode. Typical duration of undershoot is approximately 15µs. An increased reactance of the SCL line is likely to increase this effect. Undershoot does not affect the recognition of the SCL rising edge by the MLX90614, but may affect proper operation of non-MLX90614 slaves on the same bus.

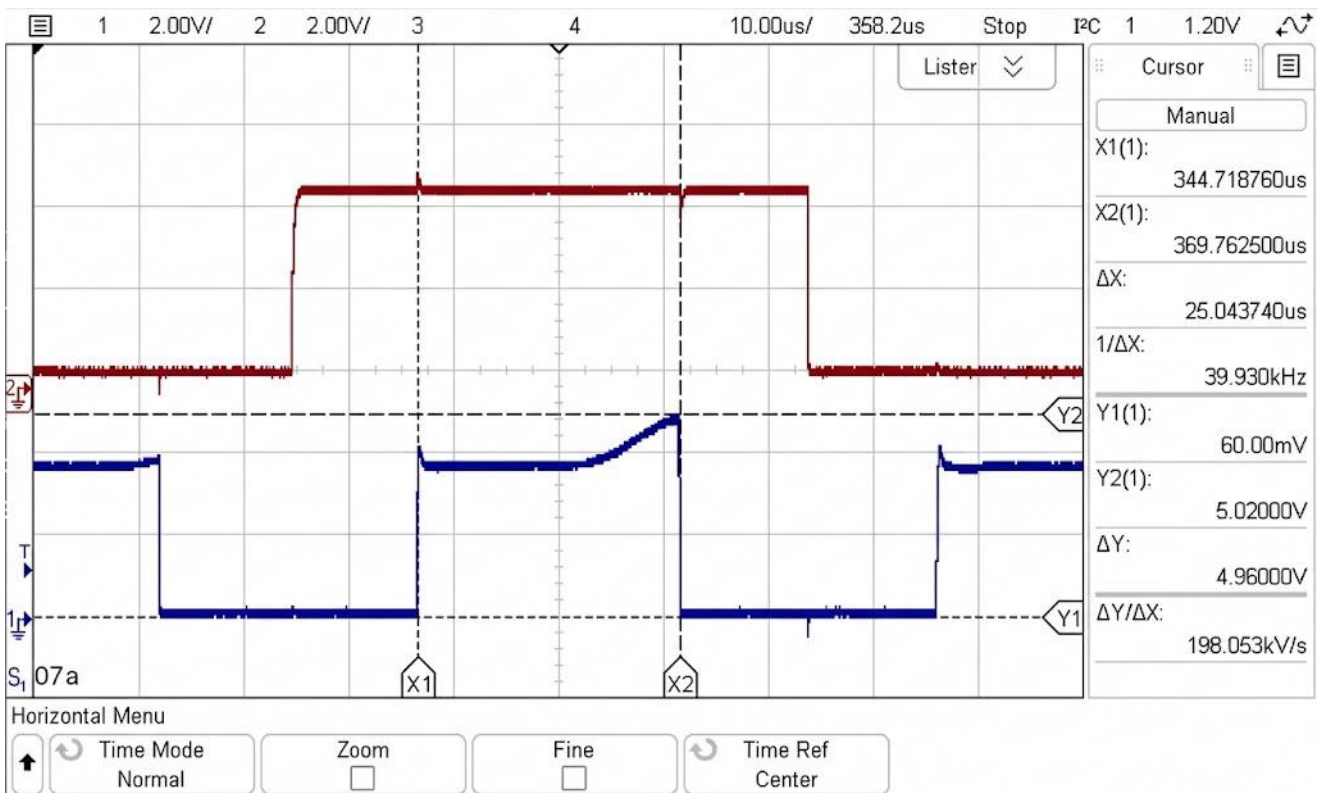

Figure 12 – Undershoot of SCL line due to on chip synthesized Zener diode (5V versions only)

Continuous SMBus readings can introduce an error. As the SCL line inside TO39 package is passing relatively close to the sensor input an error signal is induced to the sensor output. The manifestation of the problem is wrong temperature readings. This is especially valid for narrow FOV devices. Possible solution is to keep SDA and SCL line quiet for a period longer than the refresh rate and the settling time defined by the internal settings of MLX90614 prior reading the temperature or switch to PWM signal and completely disconnect from SDA and SCL line.

MLX90614

Single and dual zone IR sensor in TO39
 Datasheet



4.1.5 PWM (Pulse Width Modulation) mode

The MLX90614 can be read via PWM or SMBus compatible interface. Selection of PWM output is done in EEPROM configuration (factory default is SMBus). PWM output has two programmable formats, single and dual data transmission, providing single wire reading of two temperatures (dual zone object or object and ambient). The PWM period is derived from the on-chip oscillator and is programmable.

Config Register[5:4]	PWM1 data	PWM2 data	Tmin,1	Tmax,1	Tmin,2	Tmax,2
00	T _A	T _{O1}	T _{A, range, L}	T _{A, range, H}	T _{O, MIN}	T _{O, MAX}
01	T _A	T _{O2}	T _{A, range, L}	T _{A, range, H}	T _{O, MIN}	T _{O, MAX}
11	T _{O1}	T _{O2}	T _{O, MIN}	T _{O, MAX}	T _{O, MIN}	T _{O, MAX}
10*	T _{O2}	Undefined	T _{O, MIN}	T _{O, MAX}	NA	NA

Table 17 – PWM configuration table

NOTE: Serial data functions (2-wire / PWM) are multiplexed with a thermal relay function (described in the “Thermal relay” section).

* Not recommended for extended PWM format operation

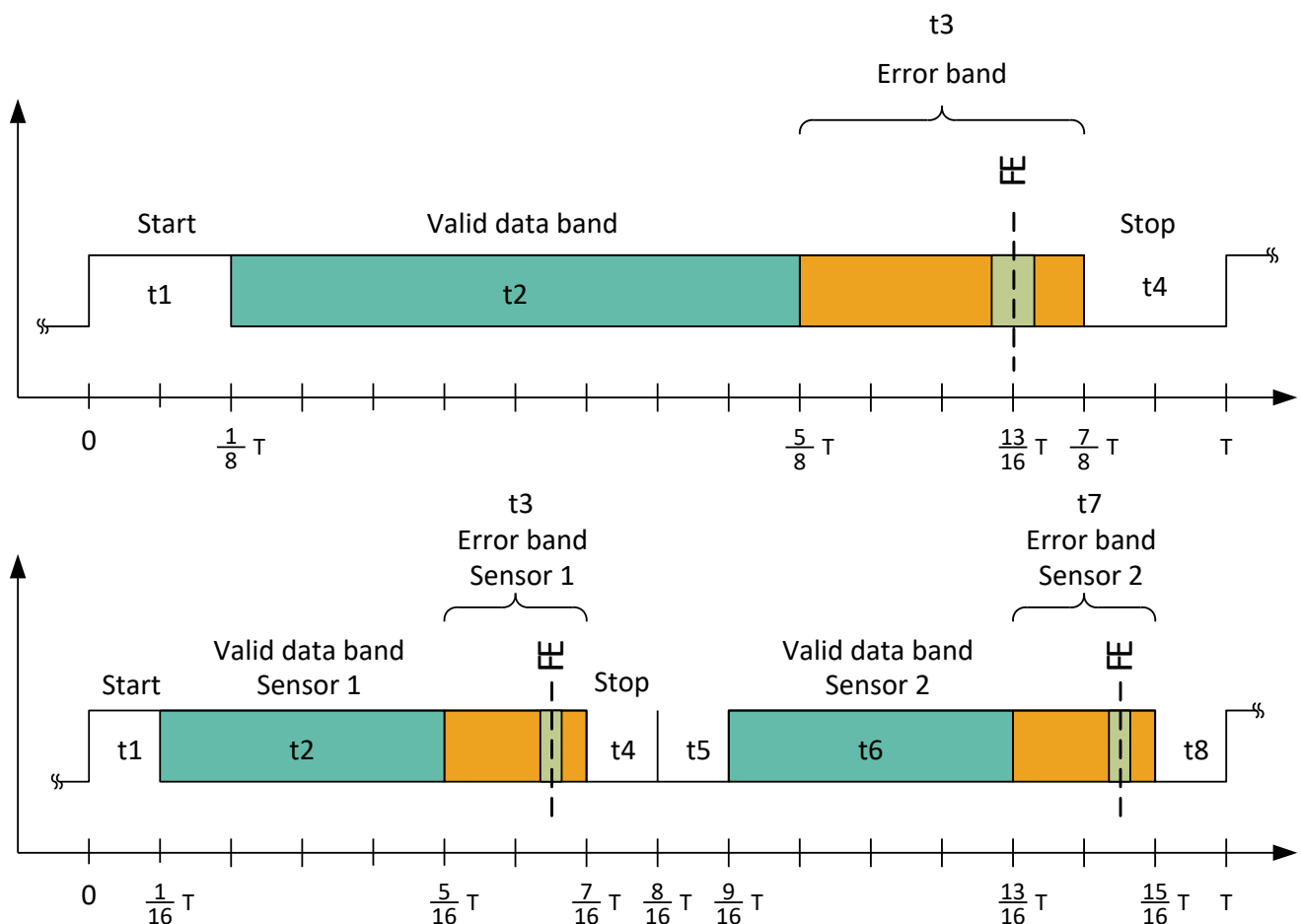

Figure 13 – PWM timing single (above) and extended mode (below)

PWM type	t1	t2	t3	t4	t5	t6	t7	t8
Single	1/8 - high	4/8 - var	2/8	1/8 - low	NA	NA	NA	NA
Extended - S1	1/16 - high	4/16 - var	2/16	1/16 - low	1/16 - low	4/16 - low	2/16 - low	1/16 - low
Extended - S2	1/16 - high	4/16 - high	2/16 - high	1/16 - high	1/16 - high	4/16 - var	2/16	1/16 - low

Table 18 – PWM timing depending on the PWM mode

4.1.5.1 Single PWM format

In single PWM output mode the settings for PWM1 data only are used. The temperature reading can be calculated from the signal timing as:

$$T_{OUT} = \left(\frac{2t_2}{T} (T_{O_MAX} - T_{O_MIN}) \right) + T_{O_MIN}$$

where Tmin and Tmax are the corresponding rescale coefficients in EEPROM for the selected temperature output (Ta, object temperature range is valid for both Tobj1 and Tobj2 as specified in the previous table) and T is the PWM period. Tout is T01, T02 or Ta according to Config Register [5:4] settings.

The different time intervals t1...t4 have the following meaning:

t1: Start buffer. During this time the signal is always high. t1 = 0.125s x T (where T is the PWM period, please refer to Figure 13).

t2: Valid Data Output Band, 0...1/2T. PWM output data resolution is 10 bit.

t3: Error band – information for fatal error in EEPROM (double error detected, not correctable).

t3 = 0.25s x T. Therefore, a PWM pulse train with a duty cycle of 0.875 will indicate a fatal error in EEPROM (for single PWM format). FE means Fatal Error.

Example:

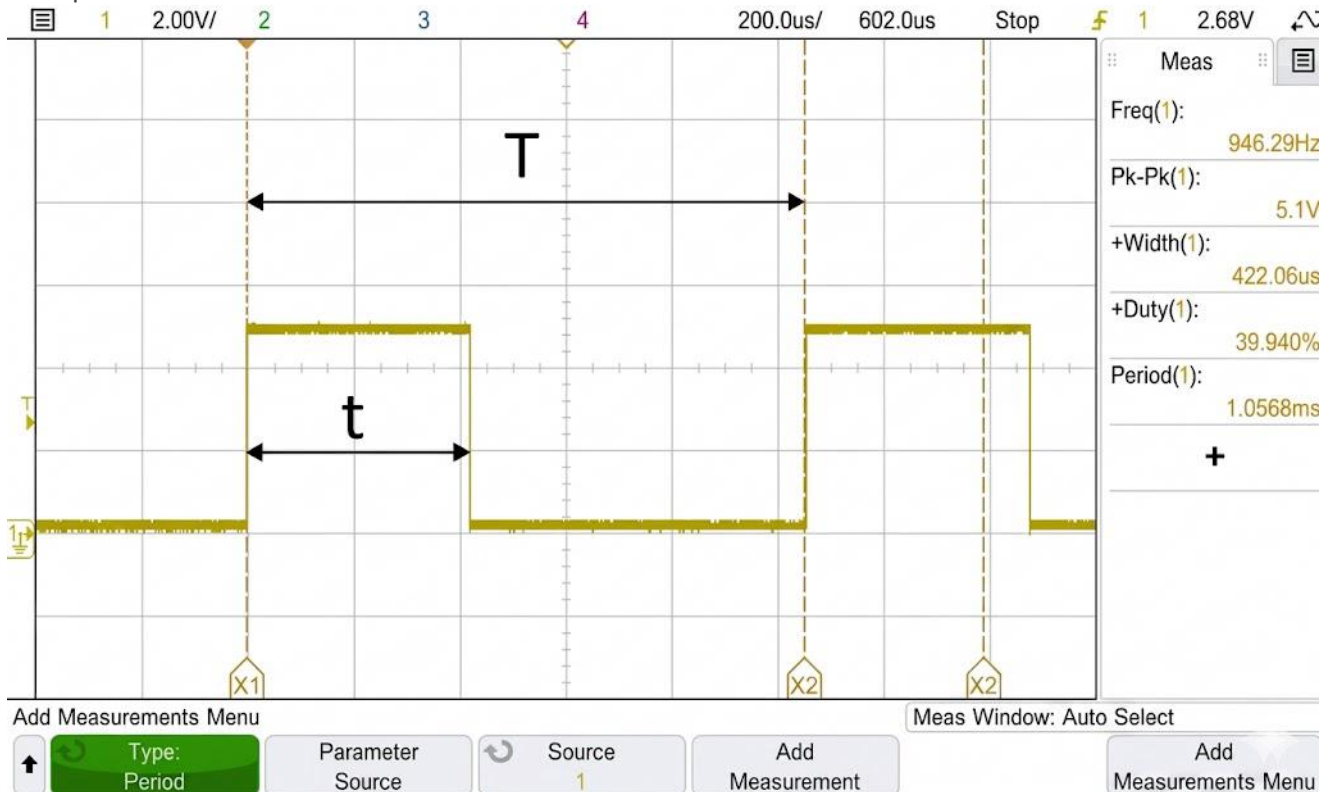

Figure 14 – PWM example – single mode

$$T_{O_MAX} = 50^{\circ}C \rightarrow T_{O_MAX}(EEPROM, 0x00) = 100 * (T_{O_MAX} + 273.15) = 32315 = 0x73EB$$

$$T_{O_MIN} = 0^{\circ}C \rightarrow T_{O_MIN}(EEPROM, 0x01) = 100 * (T_{O_MIN} + 273.15) = 27315 = 0x6AB3$$

Captured PWM period is T = 1056.8µs

Captured high duration is t = 422.06µs

MLX90614

Single and dual zone IR sensor in TO39
 Datasheet

Calculated duty cycle is:

$$D = \frac{t}{T} = \frac{422.06}{1056.8} = 0.39937 \text{ or } 39.94\%$$

The temperature is calculated as follows:

$$T_o = 2 * (0.3994 - 0.125) * (50 - 0) + 0 = 2 * 0.2744 * 50 = 27.44^{\circ}\text{C}$$

4.1.5.2 Extended PWM format

The PWM format for extended PWM is shown in Figure 16. Note that for repetition bits > 0x00 each period will be outputted 2N+1 times, where N is the decimal value of the number written in *PWM control [8:4]*, like shown on Figure 15.

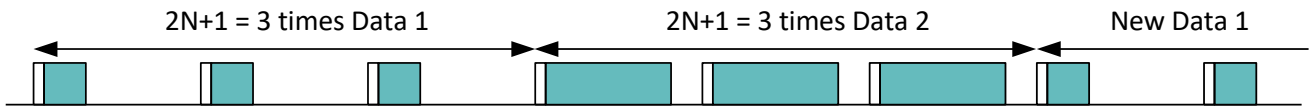

Figure 15 – PWM repetition number, PWM control [8:4] = 1 resulting in 1 data + 2 times repetition

The temperature transmitted in Data 1 field can be calculated using the following equation:

$$T_{OUT1} = \left(\frac{4t_2}{T} * (T_{O_MAX} - T_{O_MIN}) \right) + T_{O_MIN}$$

For Data 2 field the equation is:

$$T_{OUT} = \left(\frac{4t_6}{T} * (T_{O_MAX} - T_{O_MIN}) \right) + T_{O_MIN}$$

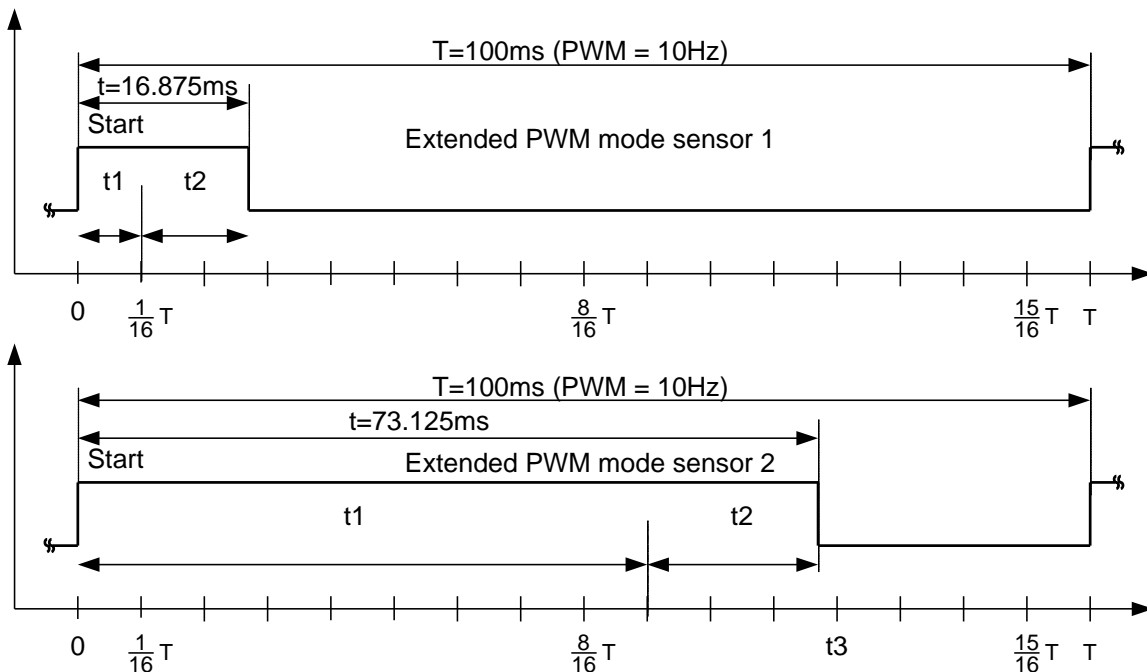

Figure 16 – Example: extended PWM mode readings – sensor 1 above and sensor 2 below

MLX90614

Single and dual zone IR sensor in TO39
Datasheet



Time bands are:

- Sensor 1: $t_1 = 0 \dots 0.0625 * T$ - Start
- Sensor 1: $t_2 = 0.0625 * T \dots 0.3125 * T$ - Valid data
- Sensor 2: $t_1 = 0 \dots 0.5625 * T$ - Start
- Sensor 2: $t_2 = 0.5625 * T \dots 0.8125 * T$ - Valid data

Example: (see Figure 16 above):

Device configuration:

Sensor1 = T_a , Sensor2 = T_{obj1} → Config Reg [5:4] = 00b,

$$T_{A_MIN} = 0^\circ C \rightarrow T_{A_RANGE_L}(EEPROM) = 100 * \frac{(T_{A_MIN} + 38.2)}{64} = 59.6875 \approx 60 = 0x3C$$

$$T_{A_MAX} = 60^\circ C \rightarrow T_{A_RANGE_H}(EEPROM) = 100 * \frac{(T_{A_MAX} + 38.2)}{64} = 153.4375 \approx 153 = 0x99$$

$$T_{A_RANGE}(EEPROM, 0x03) = [T_{A_RANGE_H}; T_{A_RANGE_L}] = 0x993C$$

$$T_{O_MIN} = 0^\circ C \rightarrow T_{O_MIN}(EEPROM) = 100 * (T_{O_MIN} + 273.15) = 27315 = 0x6AB3$$

$$T_{O_MAX} = 0^\circ C \rightarrow T_{O_MAX}(EEPROM) = 100 * (T_{O_MAX} + 273.15) = 32315 = 0x7E3B$$

Captured high durations are:

$$\text{Sensor 1} - t = 16.875\text{ms at period } T = 100\text{ms thus the duty cycle is } Duty_{S1} = \frac{16.875}{100} = 0.16875$$

$$\text{Sensor 2} - t = 73.125\text{ms at period } T = 100\text{ms thus the duty cycle is } Duty_{S2} = \frac{73.125}{100} = 0.73125$$

The temperatures are calculated as follows:

$$T_A = 4 * (Duty_{S1} - Start_{S1}) * (T_{A_MAX} - T_{A_MIN}) + T_{A_MIN}$$

$$T_A = 4 * (0.16875 - 0.0625) * (60 - 0) + 0 = 25.5^\circ C$$

$$T_{O1} = 4 * (Duty_{S2} - Start_{S2}) * (T_{O_MAX} - T_{O_MIN}) + T_{O_MIN}$$

$$T_A = 4 * (0.73125 - 0.5625) * (50 - 0) + 0 = 33.75^\circ C$$

MLX90614

Single and dual zone IR sensor in TO39
 Datasheet

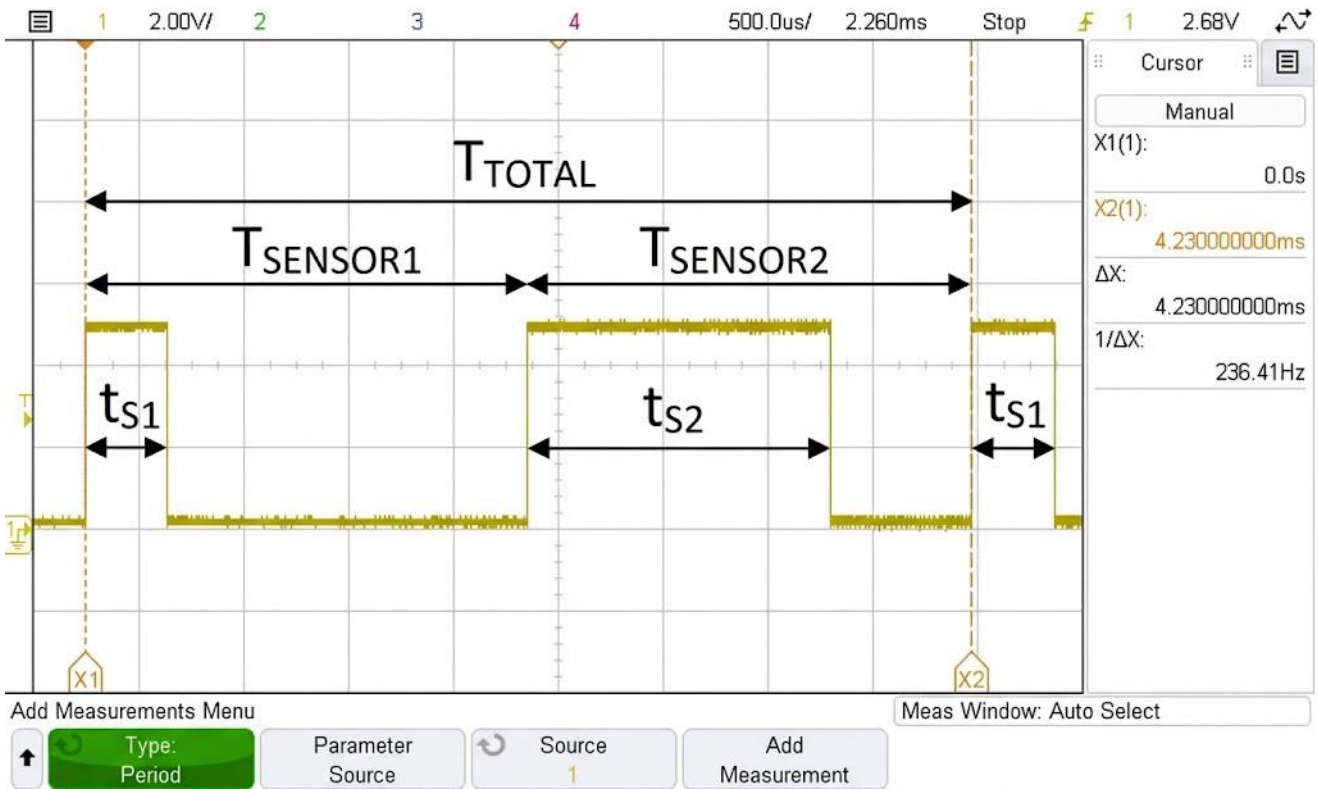

Figure 17 – PWM example - extended mode

From the example on Figure 17 can be seen that:

$$DUTY_{SENSOR1} = \frac{t_{S1}}{T_{SENSOR1}}$$

$$DUTY_{SENSOR2} = \frac{t_{S2}}{T_{SENSOR2}}$$

4.1.6 Switching between PWM / Thermal relay and SMBus

4.1.6.1 PWM mode enabled in the EEPROM settings

The diagram below illustrates the way of switching to SMBus if PWM / Thermal Relay is enabled (factory programmed POR default for MLX90614 is SMBus, PWM disabled). Note that the SCL pin must be kept high in order to use PWM.

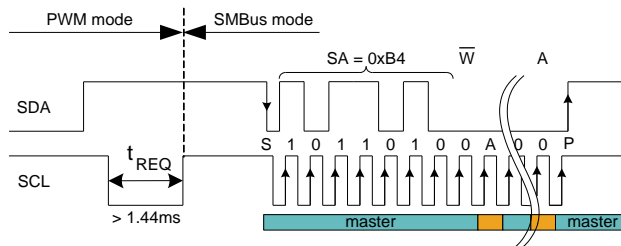

Figure 18 – Switching from PWM mode to SMBus

If PWM / Thermal relay is enabled, the MLX90614’s SMBus Request condition is needed to disable PWM / Thermal relay and reconfigure PWM/SDA pin before starting SMBus communication. Once PWM / Thermal

MLX90614

Single and dual zone IR sensor in TO39
Datasheet

relay is disabled, it can be only enabled by switching the supply OFF – ON or exit from Sleep Mode. The MLX90614’s SMBus request condition requires forcing LOW the SCL pin for a period longer than the request time ($t_{REQ} > 1.44ms$). The SDA line value is ignored and is irrelevant in this case.

4.1.6.2 PWM mode disabled in the EEPROM settings

If PWM is disabled by means of EEPROM the PWM / SDA pin is directly configured for SMBus after POR. **Request condition is not necessary to be sent in this case.**

4.1.7 Thermal relay

The MLX90614 can be configured as a thermo relay with programmable threshold and hysteresis on the PWM/SDA pin. The input for the comparator unit of the relay is the object temperature from sensor 1

The output of the MLX90614 is NOT a relay driver but a logical output which should be connected to a relay driver if necessary.

The output driver is one and the same for PWM and Thermal relay.
In order to configure the MLX90614 to work as thermal relay two conditions must be met:

- Set bit TRPWMB high at address 0x02 in EEPROM
- Enable PWM output i.e. EN_PWM is set high

The PWM / SDA pin can be programmed as a push-pull or open drain NMOS (via bit PPODB in EEPROM PWMCTRL), which can trigger an external device. The temperature threshold data is determined by EEPROM at address 0x21 (T_{Omin}) and the hysteresis at address 0x020 (T_{Omax}).

The logical state of the PWM/SDA pin is as follows:

PWM / SDA pin is high if $T_{O1} \geq Threshold + hysteresis$

PWM / SDA pin is low if $T_{O1} \leq Threshold - hysteresis$

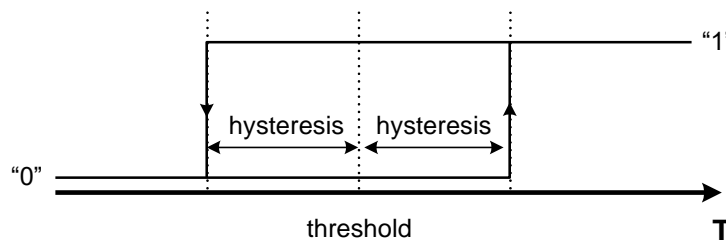

Figure 19 – Thermal relay: PWM (SDA) pin versus T_{obj}

The MLX90614 preserves its normal operation when configured as a thermal relay (PWM configuration and specification applies as a general rule also for the thermal relay) and therefore it can be read using the SMBus (entering the SMBus mode from both PWM and thermal relay mode is the same).

For example, the MLX90614 can generate a wake-up alert for a system upon reaching a certain temperature and then be read as a thermometer. Reset conditions (enter and exit Sleep, for example) will be needed in order to return to the thermal relay mode.

MLX90614

Single and dual zone IR sensor in TO39
Datasheet



Example:

$$\text{Threshold} = 5^{\circ}\text{C} \rightarrow \text{EEPROM}[0x01] = 100 * (\text{Threshold} + 273.15) = 27815 = 0x6CA7$$

$$\text{Hysteresis} = 1^{\circ}\text{C} \rightarrow \text{EEPROM}[0x00] = 100 * \text{Hysteresis} = 100 = 0x0064$$

Smallest possible hysteresis is 0,01°C or (EEPROM, 0x00 = 0x0001)

PWM / SDA pin will be set low at object temperature below 4°C

PWM / SDA pin will be set high at object temperature higher than 6°C

4.1.8 Computation of ambient and object temperature

The IR sensor consists of serial connected thermo-couples with cold junctions placed at thick chip substrate and hot junctions, placed over thin membrane. The IR radiation absorbed from the membrane heats (or cools) it. The thermopile output signal is:

$$V_{IR}(T_a, T_o) = A * (T_o^4 - T_a^4)$$

Where T_o is the absolute object temperature (Kelvin), T_a is the sensor die absolute (Kelvin) temperature, and A is the overall sensitivity.

An on-board temperature sensor is needed to measure the chip temperature. After measurement of the output of both sensors, the corresponding ambient and object temperatures can be calculated. These calculations are done by the internal DSP, which produces digital outputs, linearly proportional to measured temperatures.

4.1.8.1 Ambient temperature – T_a

The Sensor die temperature is measured with a PTAT element. All the sensors conditioning and data processing is handled on-chip and the linearized sensor die temperature T_a is available in memory.

The resolution of the calculated temperature is 0.02°C. The sensor is factory calibrated for the full automotive range -40...+125°C. The linearized die temperature is available in RAM cell 0x06:

0x06=0x2DE4 (11748d) corresponds to -38.2°C (linearization output lower limit)

0x06=0x4DC4 (19908d) corresponds to +125°C. (linearization output higher limit)

The conversions from RAM content to real T_a is easy using the following relation:

$$T_a[{}^{\circ}\text{K}] = T_{areg} * 0.02 \text{ or } 0.02^{\circ}\text{K} / \text{LSB}$$

MLX90614

Single and dual zone IR sensor in TO39
Datasheet

4.1.8.2 Object temperature – To

Please note that 1LSb corresponds to 0.02°C and the MSb is an error flag (if “1” then error).

Example:

1. 0x27AD → -70.00°C (no error)
2. 0x27AE → -69.98°C (no error)
3. 0x3AF7 → 28.75°C (no error)
4. 0x3AF8 → 28.77°C (no error)
5. 0x7FFF → 382.19°C (no error) - maximum possible value returned by MLX90614
6. 0x8XXX → xxx.xx°C (flag error)

The result is calculated by following expressions (valid for both To and Ta):

1. Convert it to decimal value i.e. 0x3AF7 = 15095d
2. Divide by 50 (or multiply by 0.02) i.e. $\frac{5095}{50} = 301.9\text{K}$ (result is in Kelvin)
3. Convert K to °C i.e. 301.9 - 273.15 = 28.75°C

4.1.8.3 Calculation flow

The measurement, calculation and linearization are performed by the core, which executes a program from ROM.

After POR the chip is initialized with calibration data from EEPROM. During this phase the number of IR sensors is selected and it is decided which temperature sensor will be used. Measurements, compensation and linearization routines run in a closed loop afterwards.

Processing ambient temperature includes:

- Offset measurement with fixed length FIR filter
- Additional filtering with fixed length IIR filter. The result is stored into RAM as T_{OS}
- Temperature sensor measurement using programmable length FIR *.
- Offset compensation
- Additional processing with programmable length IIR **. The result is stored into RAM as T_D.
- Calculation of the ambient temperature. The result is stored into RAM address 0x06 as T_A

Processing of the object temperature consists of three parts.

The first one is common for both IR sensors, the third part can be skipped if only one IR sensor is used.

IR offset:

- Offset measurement with a fixed length FIR
- Additional filtering with a fixed length IIR. The result is stored into RAM as IR_{OS}.
- Gain measurement with fixed length FIR filter
- Offset compensation
- Additional gain filtering with fixed length IIR, storing the result into RAM as IR_G.
- Gain compensation calculation, the result is stored into RAM as K_G

MLX90614

Single and dual zone IR sensor in TO39
 Datasheet

Object temperature:

R1 sensor:

- IR sensor measurement with programmable length FIR filter *
- Offset compensation
- Gain compensation
- Filtering with programmable length IIR filter**, storing the result into RAM address 0x04 as IR1_D.
- Calculation of the object temperature. The result is available in RAM address 0x07 as T_{Obj1}.

IR2 sensor:

- IR sensor measurement with programmable length FIR filter *
- Offset compensation
- Gain compensation
- Filtering with programmable length IIR filter**, storing the result into RAM address 0x05 as IR2_D.
- Calculation of the object temperature. The result is available in RAM address 0x08 as T_{Obj2}.

PWM calculation:

- Recalculate the data for PWM with 10-bit resolution
- Load data into PWM module

NOTE*: The measurements with programmable filter length for FIR filter use the same EEPROM cells for N.

NOTE:** The IIR filter with programmable filter length uses the same EEPROM cells for L.

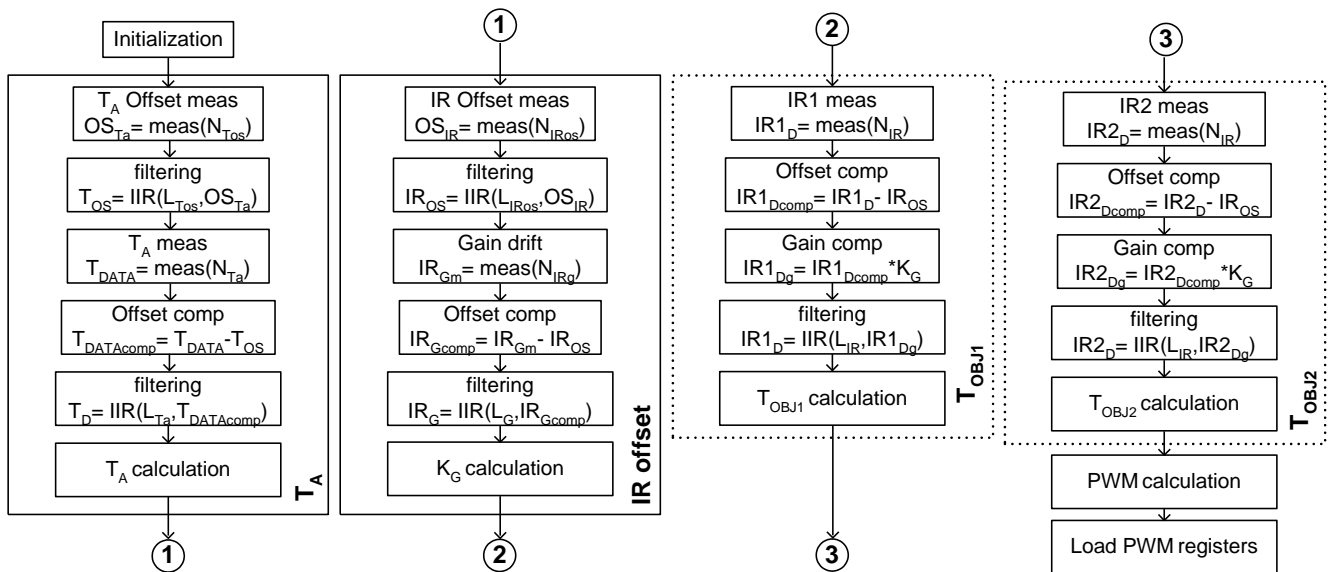

Figure 20 – Software flow

MLX90614

Single and dual zone IR sensor in TO39
Datasheet



4.2 Unique features

- The MLX90614 is a ready-to use low-cost non-contact thermometer provided by Melexis with output data linearly dependent on the object temperature with high accuracy and extended resolution.
- The high thermal stability of the MLX90614-xCx makes this part highly suitable for applications where secondary heat sources can heat up the sensor. These sensors also have a very short stabilization time compared to other types of thermopile sensors, which is of importance if one needs an accurate measurement in conditions where the ambient temperature can change quickly.
- The MLX90614 supports versatile customization to a very wide range of temperatures, power supplies and refresh rates.
- The user can program the internal object emissivity correction for objects with a low emissivity. An embedded error checking and correction mechanism provides high memory reliability.
- The sensors are housed in an industry standard TO39 package for both single- and dual-zone IR thermometers. The thermometer is available in automotive grade and can use two different packages for wider applications' coverage.
- The low power consumption during operation and the low current draw during sleep mode make the thermometer ideally suited for handheld mobile applications.
- The digital sensor interface can be either a power-up-and-measure PWM or an enhanced access SMBus compatible protocol. Systems with more than 100 devices can be built with only two signal lines. Dual zone non-contact temperature measurements are available via a single line (extended PWM).
- A built-in thermal relay function further extends the easy implementation of a wide variety of freezing/boiling prevention and alert systems, as well as thermostats (no MCU is needed).

MLX90614

Single and dual zone IR sensor in TO39
Datasheet

4.3 Performance graphs

4.3.1 Accuracy

4.3.2 Standard accuracy

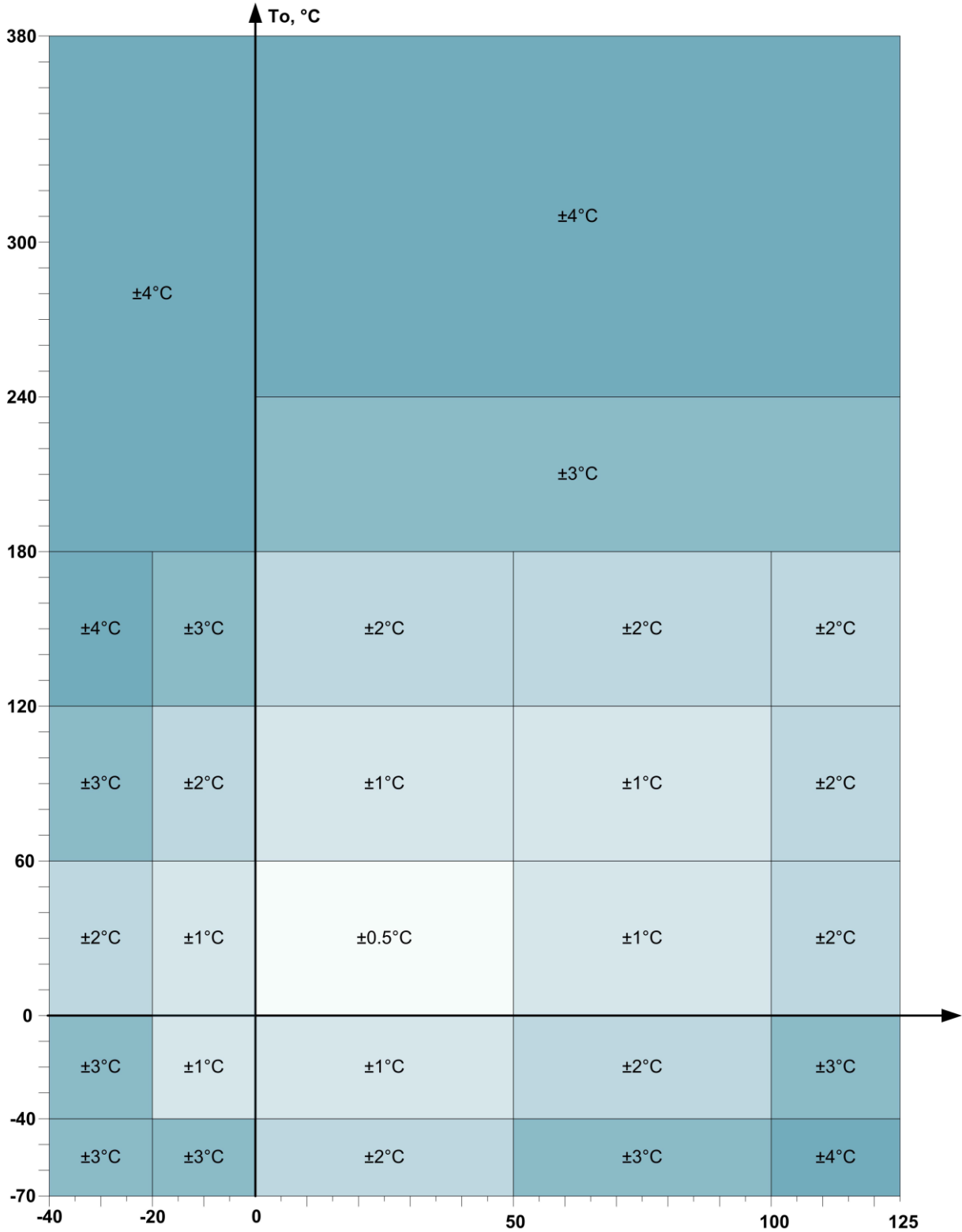

Figure 21 – Accuracy of MLX90614 (Ta, To) except for xCK type

MLX90614

Single and dual zone IR sensor in TO39
 Datasheet

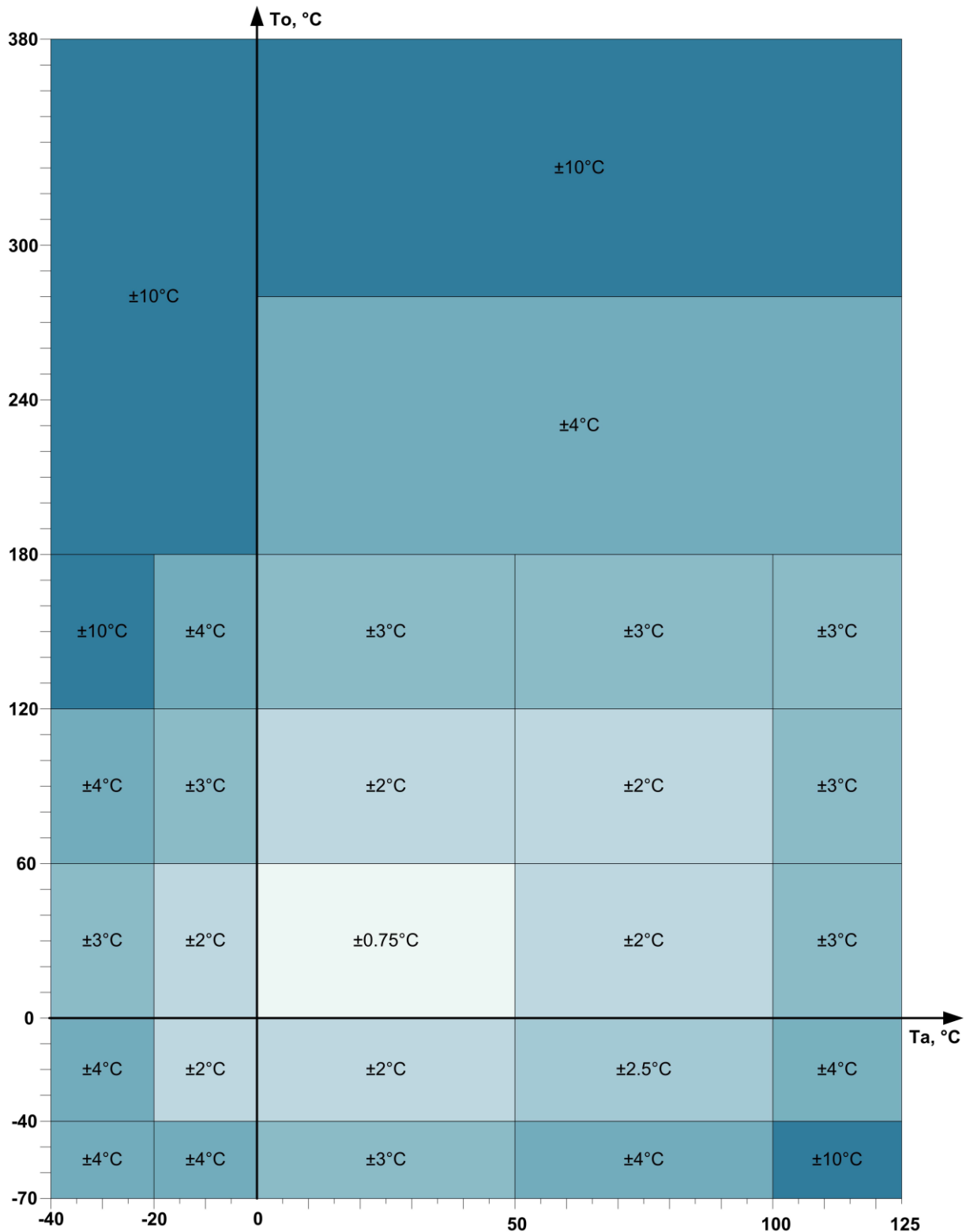

Figure 22 – Accuracy of MLX90614xCK (Ta, To) only

All accuracy specifications apply under settled isothermal conditions only. Furthermore, the accuracy is only valid if the object fills the FOV of the sensor completely.

MLX90614

Single and dual zone IR sensor in TO39
Datasheet

4.3.3 Medical accuracy

A version of the MLX90614 with accuracy suited for medical applications is available. The accuracy in the range T_a 16°C...40°C and T_o 22°C...40°C is shown in diagram below. The accuracy for the rest of the temperature ranges is the same as in previous diagram. Medical accuracy specification is only available for the MLX90614Dxx versions.

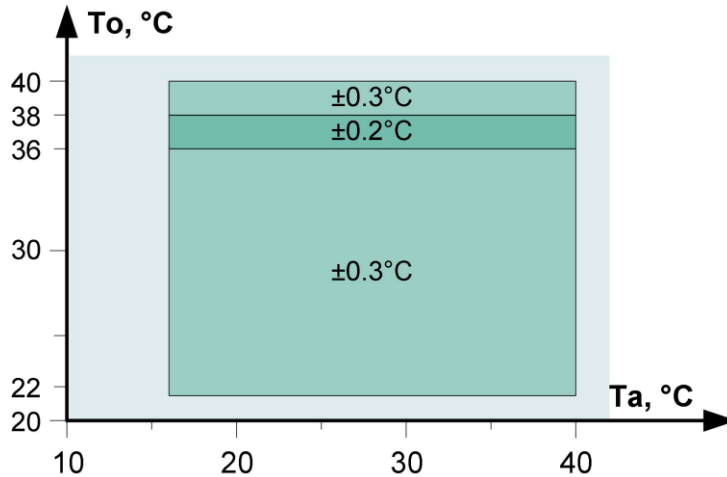

Figure 23 – Medical accuracy

Versions MLX90614ESF-DCC, -DCH and -DCI comply with ASTM standard section 5.4 (Designation: E1965 – 98 (Re-approved 2009) - Standard Specification for Infrared Thermometers for Intermittent Determination of Patient Temperature

It is very important for the application designer to understand that the accuracy specified in Figure 21 and Figure 22 is only guaranteed when the sensor is in thermal equilibrium and under isothermal conditions (there are no temperature differences across the sensor package). The accuracy of the thermometer can be influenced by temperature differences in the package induced by causes like (among others): Hot electronics (heaters / coolers) behind or beside the sensor or when the measured object is so close to the sensor that heats the thermometer package.

This effect is especially relevant for thermometers with a small FOV like the xxI, xxF and xxK as the energy received by the sensor from the object is reduced. Therefore, Melexis has introduced the xCx version of the MLX90614. In these MLX90614xCx, the thermal gradients are measured internally and the measured temperature is compensated for them. In this way, the MLX90614xCx is much less sensitive to thermal gradients induced from outside, but the effect is not totally eliminated. It is therefore important to avoid introducing strong heat sources close to the sensor or to shield the sensor from them.

NOTE: In order to have the highest possible signal and the best performance a higher gain of the amplifier is selected for MLX90614Dxx type of devices. This eventually would limit the maximum object temperature (due to overload of the ADC) to about 200°C.

4.3.4 Temperature reading dependence on VDD

In case of medical applications where high accuracy is required and the supply is provided by means of a battery, a compensation of temperature readings from VDD dependence should be done by the microcontroller. The dependence is very repeatable and compensation can easily be implemented. As this

MLX90614

Single and dual zone IR sensor in TO39
 Datasheet



dependence comes from the ambient temperature it is the same for all type of devices regardless of FOV and optics used and it directly translates in the same compensation for object temperature.
 The typical VDD dependence of the ambient and object temperature is 0.6°C/V.

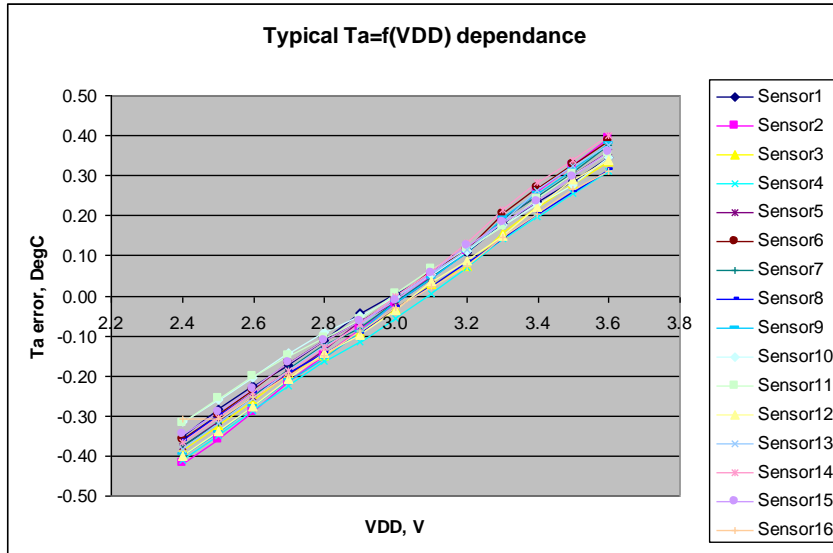

Figure 24 – Typical Ta dependence from supply voltage

Example: As the devices are calibrated at VDD=3V the error at VDD=3V is smallest one. The error in ambient channel is directly transferred as object channel error (see Figure 25 below).

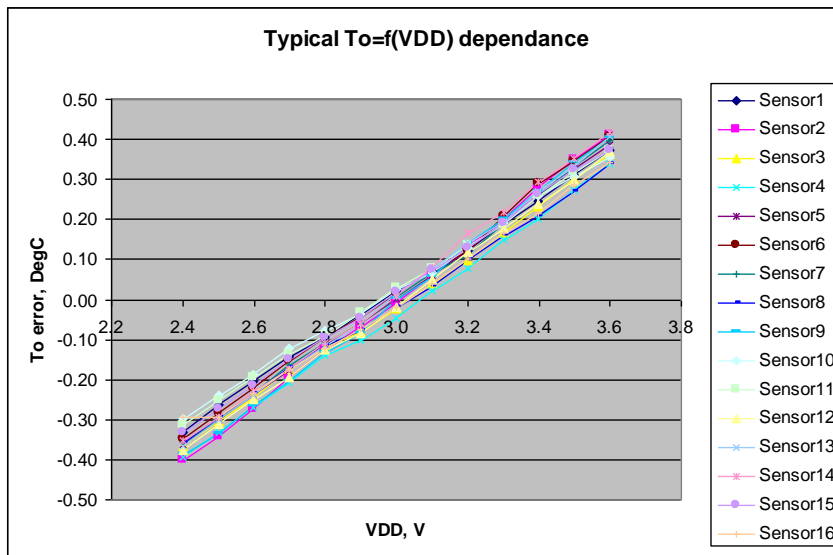

Figure 25 – Typical To dependence from supply voltage (practically the same as Ta dependence error)

In order to compensate for this error, we measure supply voltage and by applying the following equation.

$$T_{O_compensated} = T_O - (VDD - VDD_0) * Typical_dependence = T_O - (VDD - 3) * 0.6$$

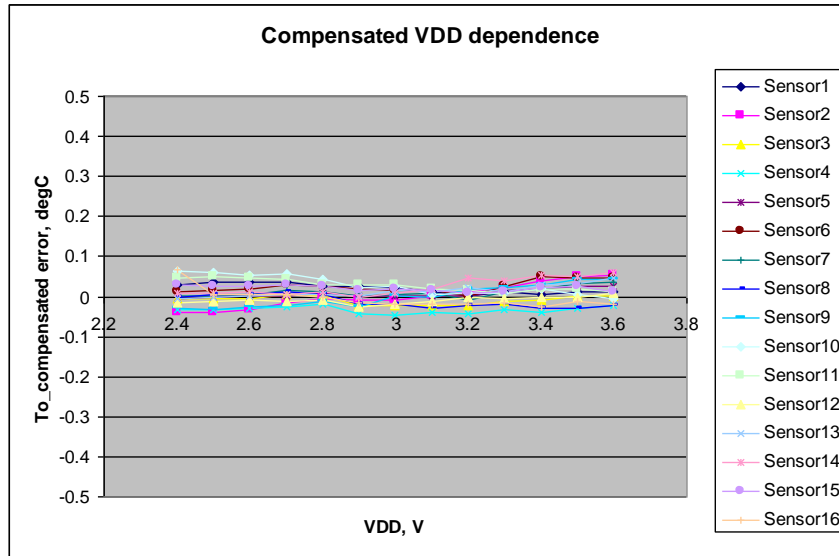

Figure 26 – Typical To error after compensation of VDD dependence

4.3.5 Field of view (FOV)

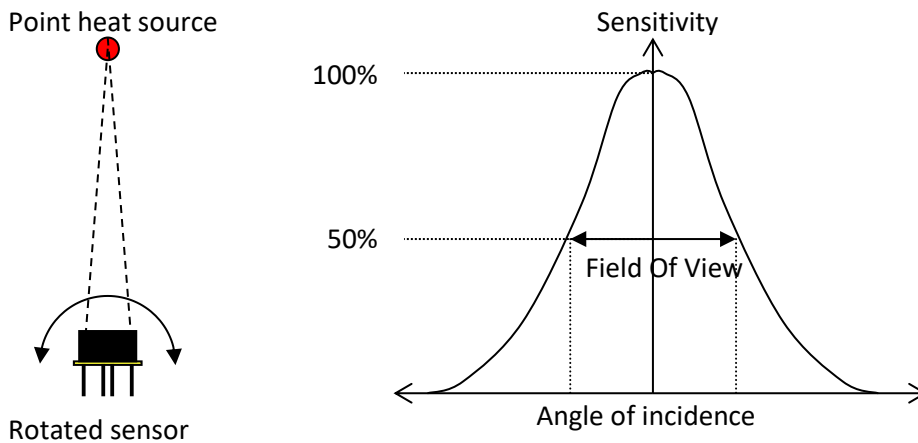

Figure 27 – Field Of View (FOV) measurement concept

Parameter	Type xAA	Type xBA	Type xCC	Type xCF	Type xCH	Type xCI	Type xCK
Peak zone 1	0°	+25°	0°	0°	0°	0°	0°
Width zone 1	90°	70°	35°	10°	10°	5°	13°
Peak zone 1	NA	+25°	NA	NA	NA	NA	NA
Width zone 1	NA	70°	NA	NA	NA	NA	NA

Table 19 – FOV summary

MLX90614

Single and dual zone IR sensor in TO39
Datasheet

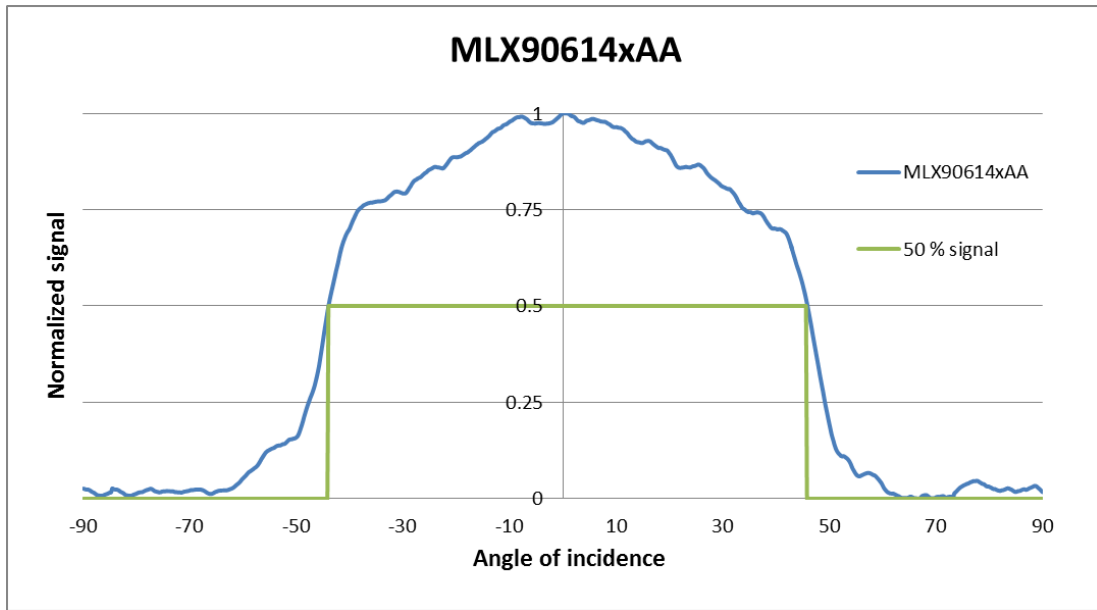

Figure 28 – Typical FOV of MLX90614xAA

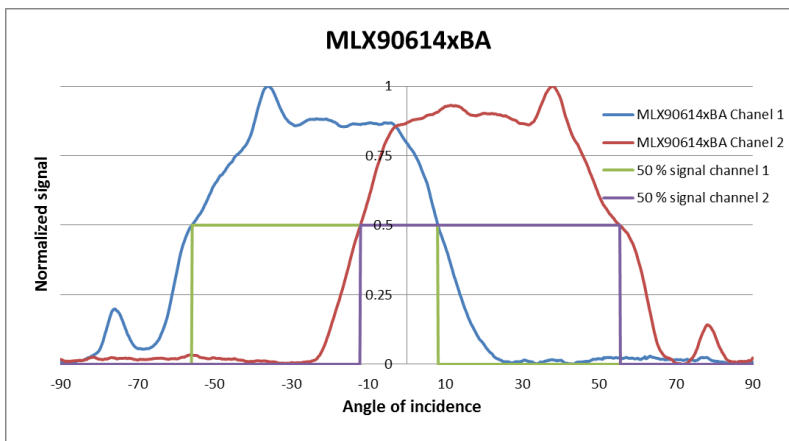

Figure 29 – Typical FOV of MLX90614xBA, Zone 1 & 2 identification relative to the alignment tab

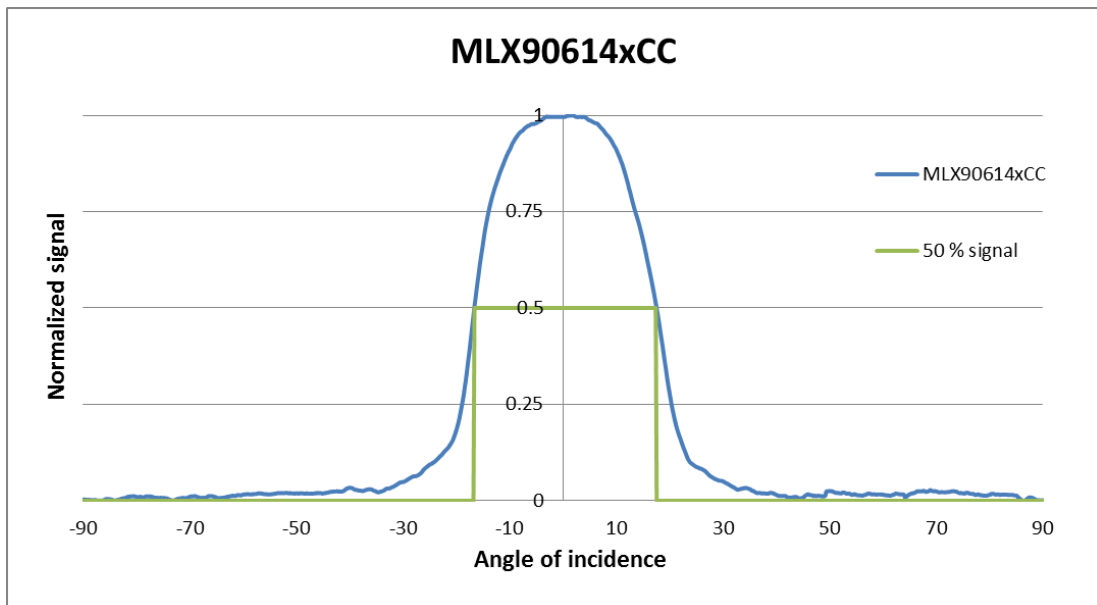

Figure 30 – Typical FOV of MLX90614xCC

MLX90614

Single and dual zone IR sensor in TO39
Datasheet

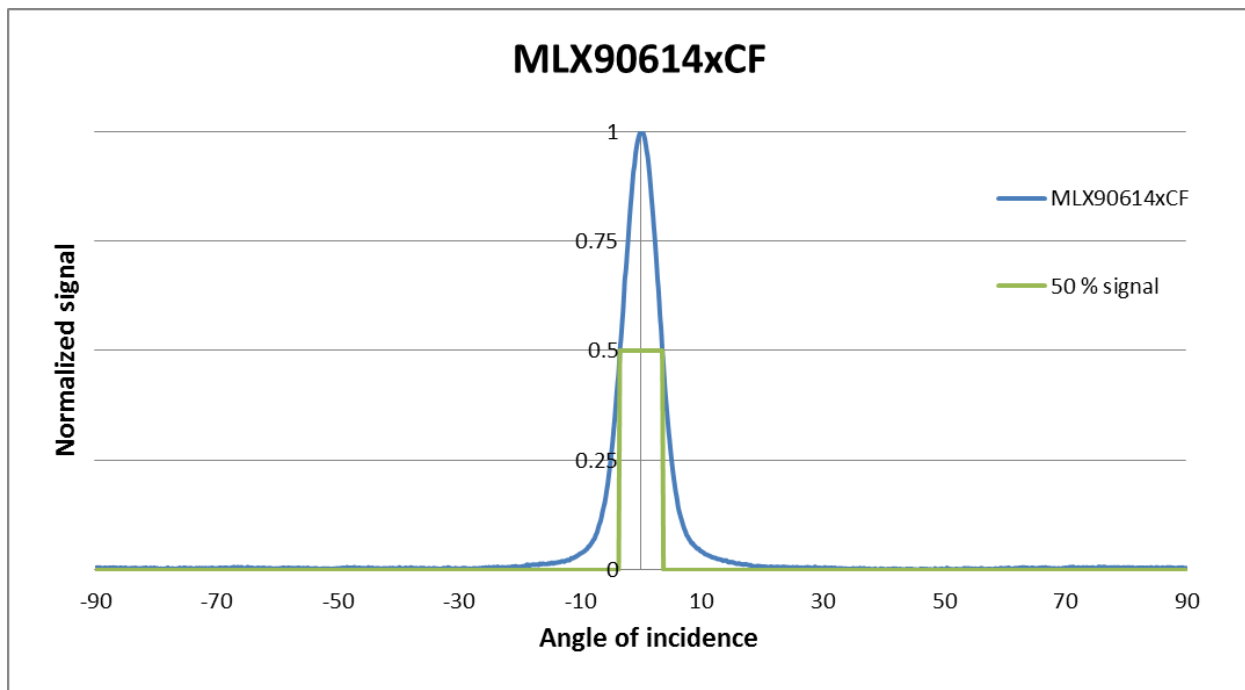

Figure 31 – Typical FOV of MLX90614xCF

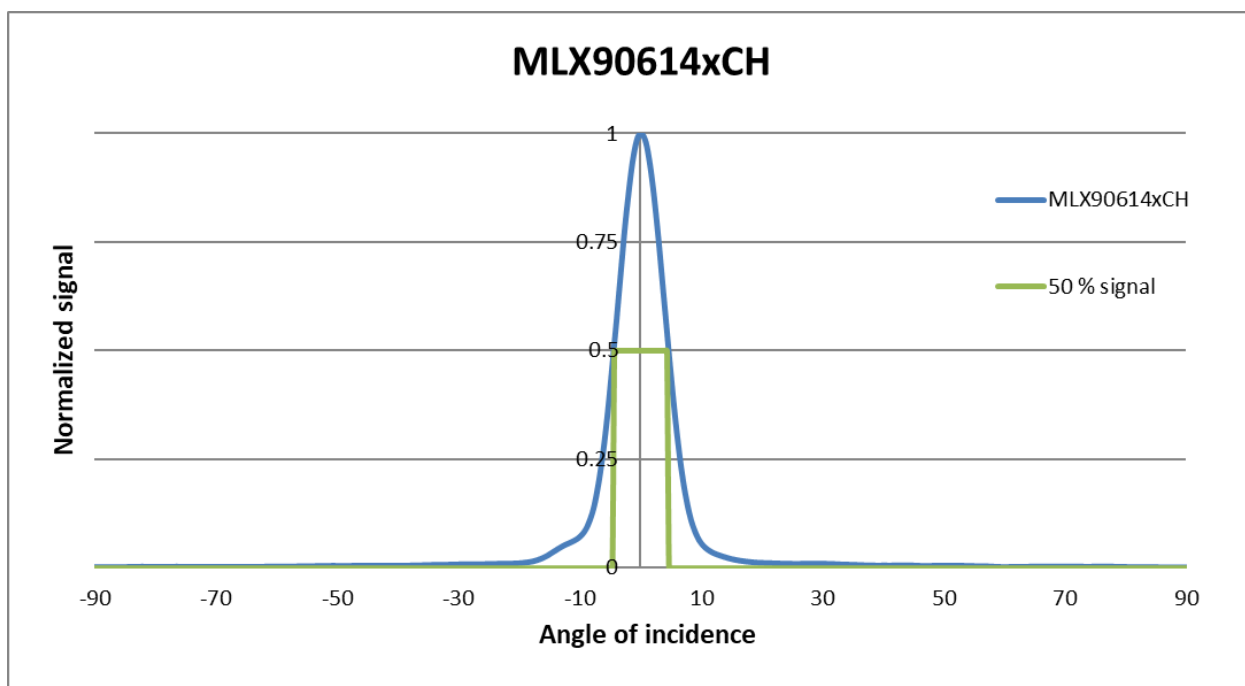

Figure 32 – Typical FOV of MLX90614xCH

MLX90614

Single and dual zone IR sensor in TO39
Datasheet

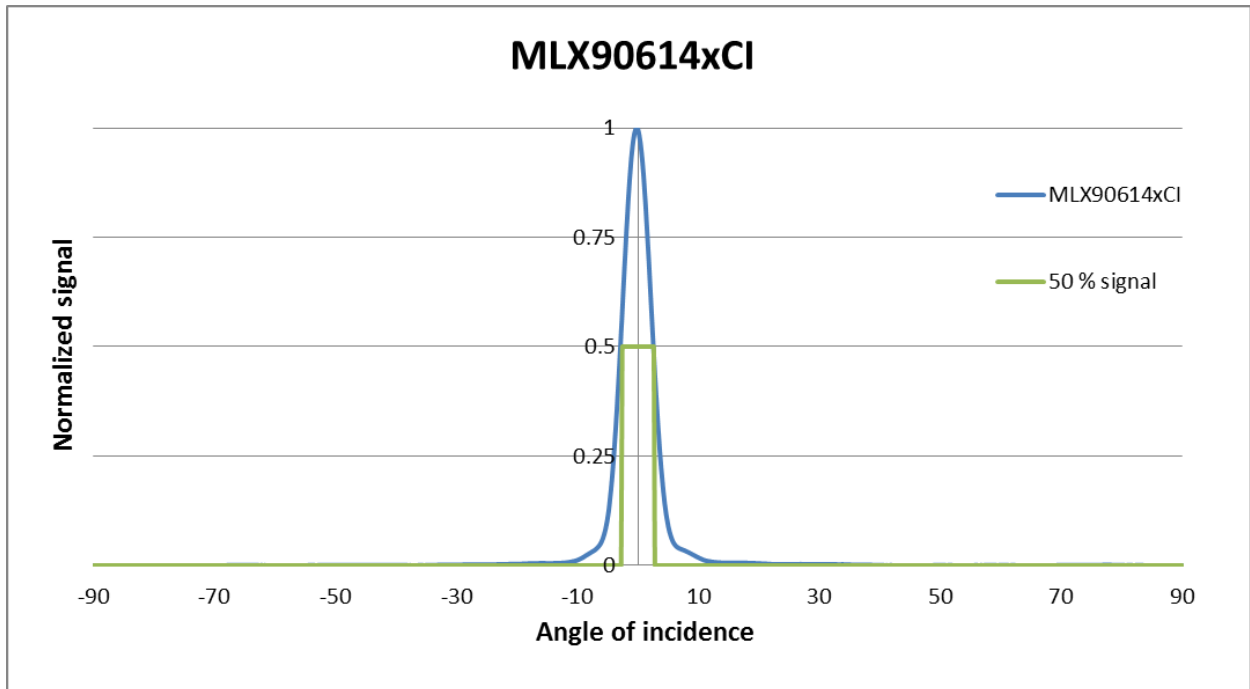

Figure 33 – Typical FOV of MLX90614xCI

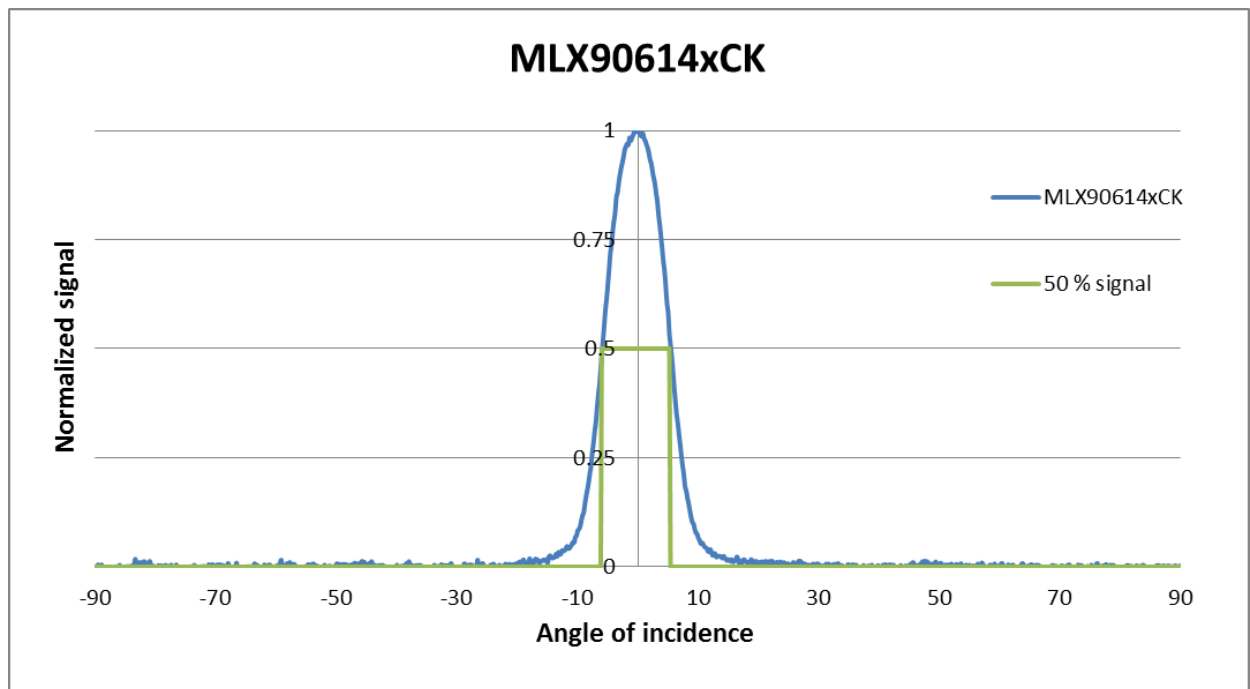

Figure 34 – Typical FOV of MLX90614xCK

MLX90614

Single and dual zone IR sensor in TO39
Datasheet

5 Application

5.1 Recommended Application diagram – SMBus configuration

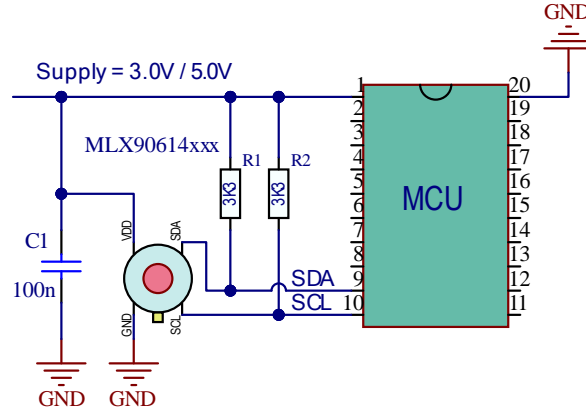

Figure 35 – MLX90614 electrical connections in SMBus communication

Figure 35 shows the connection of a MLX90614 to a SMBus with 3.0V power supply. The MLX90614 has diode clamps SDA / SCL to Vdd so it is necessary MLX90614 to be powered in order not to load the SMBus lines.

5.2 Multiple MLX90614xxx on the SMBus

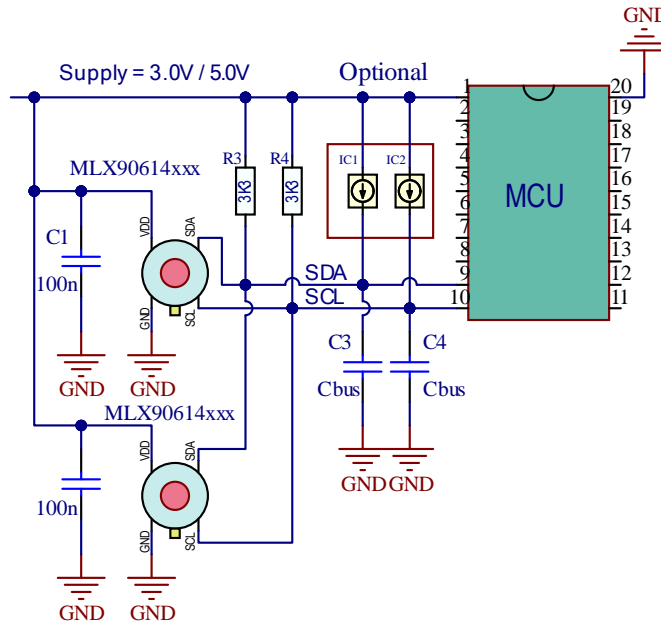

Figure 36 – Use of multiple MLX90614 devices in SMBus network

The MLX90614 supports a 7-bit slave address in EEPROM, thus allowing up to 127 devices to be read via two common wires. With the MLX90614xBx this results in 254 object temperatures measured remotely and an additional 127 ambient temperatures which are also available. Current source pull-ups may be preferred with higher capacitive loading on the bus (C3 and C4 represent the lines' parasitic), while simple resistive pull-ups provide the obvious low-cost advantage.

MLX90614

Single and dual zone IR sensor in TO39
Datasheet

5.3 PWM output operation

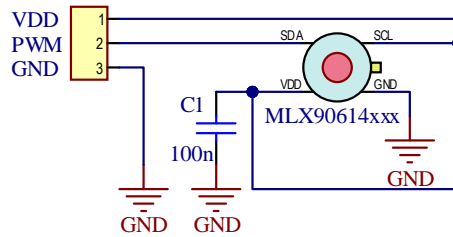

Figure 37 – Connection of MLX90614 for PWM output mode

The PWM mode is free-running after POR when configured in EEPROM. The SCL pin must be forced high for PWM mode operation (can be shorted to V_{DD} pin).

A pull-up resistor can be used to preserve the option for SMBus operation while having PWM as a default as is shown on Figure 38 – PWM output with SMBus available.

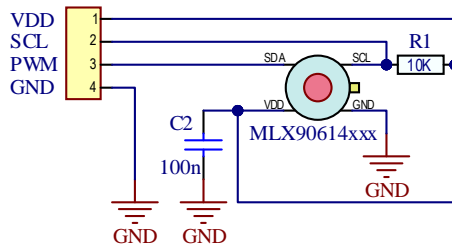

Figure 38 – PWM output with SMBus available

Again, the PWM mode needs to be written as the POR default in EEPROM. Then for PWM operation the SCL line can be high impedance, forced high, or even not connected. The pull-up resistor R1 will ensure there is a high level on the SCL pin and the PWM POR default will be active. SMBus is still available (for example – for further reconfiguration of the MLX90614, or sleep mode power management) as there are pull-up resistors on the SMBus lines anyway.

PWM can be configured as an open drain NMOS or a push-pull output. If an open drain is selected, an external pull-up resistor will be needed. This allows cheap level conversion to lower logic high voltage. Internal pull-ups present in many MCUs can also be used.

5.4 Thermal alert / thermostat

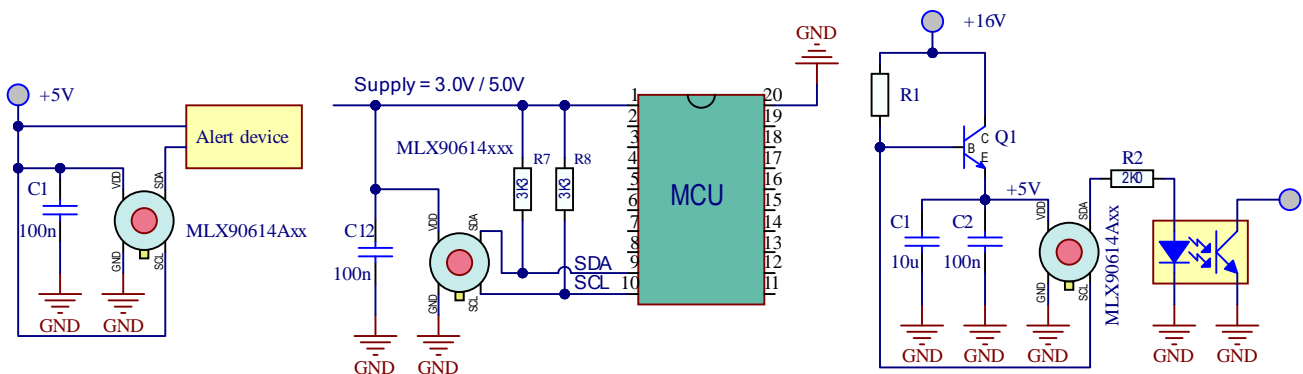

Figure 39 – Thermal alert / thermostat applications examples

MLX90614

Single and dual zone IR sensor in TO39
Datasheet

The MLX90614 can be configured in EEPROM to operate as a thermal relay. A non-contact freezing or boiling prevention with 1 mA quiescent current can be built with two components only – the MLX90614 and a capacitor. The PWM / SDA pin can be programmed as a push-pull or open drain NMOS, which can trigger an external device, such as a relay (refer to electrical specifications for load capability), buzzer, RF transmitter or a LED. This feature allows very simple thermostats to be built without the need of any MCU and zero design overhead required for firmware development. In conjunction with an MCU, this function can operate as a system alert that wakes up the MCU. Both object temperature and sensor die temperature can also be read in this configuration.

5.5 High voltage operation

As a standard, the module MLX90614Axx works with a supply voltage of 5V. In addition, thanks to the integrated internal reference regulator available at pin SCL / Vz, this module can easily be powered from a higher voltage source (like VDD=8...16V). Only a few external components as depicted in the diagram below are required to achieve this. This function is automatically activated once the voltage on SCL pin become greater than 5V.

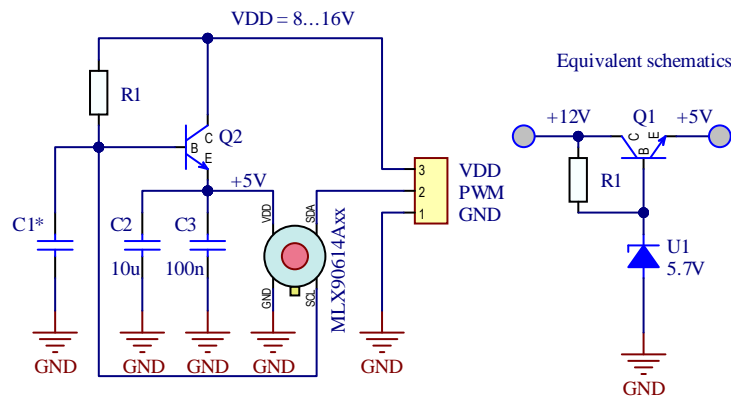

Figure 40 – High voltage regulator implementation

With the second (synthesized Zener diode) function of the SCL / Vz pin, the 2-wire interface function is available only if the voltage regulator is overdriven (5V regulated power is forced to Vdd pin).

5.6 Changing emissivity

Please follow the link to the AN explaining the necessary steps for properly changing the emissivity coefficient in MLX90614.

[Changing emissivity](#)

5.7 General application comments

Significant **contamination** at the optical input side (sensor filter) might cause unknown additional filtering and/or distortion of the optical signal and therefore result in unspecified errors.

IR sensors are inherently susceptible to errors caused by **thermal gradients**. There are physical reasons for these phenomena and, in spite of the careful design of the MLX90614, it is recommended not to subject the MLX90614 to heat transfer and especially transient conditions.

MLX90614

Single and dual zone IR sensor in TO39
Datasheet



Upon **power-up** the MLX90614 passes embedded checking and power ON routines. During these routines the output is not defined and it is recommended to wait for the specified POR time before reading the module. Very slow power-up may cause the embedded POR circuitry to trigger on inappropriate levels, resulting in unspecified operation and this is not recommended.

The MLX90614 is designed and calibrated to operate as a non-contact thermometer in **settled conditions**. Using the thermometer in a very different way will result in unpredictable results.

Capacitive loading on an SMBus can degrade the communication. Some improvement is possible with use of current sources compared to resistors in pull-up circuitry. Further improvement is possible with specialized commercially available bus accelerators. With the MLX90614 additional improvement is possible by increasing the pull-up current (decreasing the pull-up resistor values). Input levels for SMBus compatible mode have higher overall tolerance than the SMBus specification, but the output low level is rather low even with the high-power SMBus specification for pull-up currents. Another option might be to go for a slower communication (clock speed), as the MLX90614 implements Schmidt triggers on its inputs in SMBus compatible mode and is therefore not really sensitive to rise time of the bus (it is more likely the rise time to be an issue than the fall time, as far as the SMBus systems are open drain with pull-up).

For **ESD protection** there are clamp diodes between the Vss and Vdd and each of the other pins. This means that the MLX90614 might draw current from a bus in case the SCL and/or SDA is connected and the Vdd is lower than the bus pull-ups' voltage.

In **12V powered systems SMBus usage is constrained** because the SCL pin is used for the Zener diode function. Applications where the supply is higher than 5V should use the PWM output or an external regulator. Nevertheless, in the 12V powered applications MLX90614 can be programmed (configured and customized) by forcing the Vdd to 5V externally and running the SMBus communication.

A sleep mode is available in the MLX90614Bxx only. This mode is entered and exited via the SMBus compatible 2-wire communication. On the other hand, the extended functionality of the SCL pin yields in increased leakage current through that pin. As a result, this pin needs to be forced low in sleep mode and the pull-up on the SCL line needs to be disabled in order to keep the overall power drain in sleep mode really small. During sleep mode the sensor will not perform measurements.

The **PWM pin is not designed for direct drive of inductive loads** (such as electro-magnetic relays). Some drivers need to be implemented for higher load, and auxiliary protection might be necessary even for light but inductive loading.

It is possible to use the MLX90614 in applications, powered directly from the AC line (transformer less). In such cases it is very important not to forget that **the metal package of the sensor is not isolated** and therefore may occur to be connected to that line, too. Melexis cannot be responsible for any application like this and highly recommends not using the MLX90614 in that way.

Power dissipation within the package may affect performance in two ways: by heating the "ambient" sensitive element significantly beyond the actual ambient temperature, as well as by causing gradients over the package that will inherently cause thermal gradient over the cap. Loading the outputs also causes increased power dissipation. In case of using the MLX90614Axx internal Zener voltage feature, the regulating external transistor should also not cause heating of the TO39 package.

High capacitive load on a PWM line will result in significant charging currents from the power supply, bypassing the capacitor and therefore causing EMC, noise, level degradation and power dissipation problems.

MLX90614

Single and dual zone IR sensor in TO39
Datasheet



A simple option is adding a series resistor between the PWM / SDA pin and the capacitive loaded line, in which case timing specifications have to be carefully reviewed. For example, with a PWM output that is set to 1.024ms and the output format that is 11bit, the time step is 0.5 μ s and a settling time of 2 μ s would introduce a 4 LSB error.

Power supply decoupling capacitor is needed as with most integrated circuits. MLX90614 is a mixed-signal device with sensors, small signal analog part, digital part and I/O circuitry. In order to keep the noise low power supply switching noise needs to be decoupled. High noise from external circuitry can also affect noise performance of the device. In many applications a 100nF SMD ceramic capacitor close to the Vdd and Vss pins would be a good choice. It should be noted that not only the trace to the Vdd pin needs to be short, but also the one to the Vss pin. Using MLX90614 with short pins improves the effect of the power supply decoupling. Severe noise can also be coupled within the package from the SCL (in worst cases also from the SDA) pin. This issue can be solved by using PWM output. Also, the PWM output can pass additional filtering (at lower PWM frequency settings). With a simple LPF RC network added also increase of the ESD rating is possible.

5.8 FAQ

When I measure aluminum and plastic parts settled at the same conditions I get significant errors on aluminum. Why?

Different materials have different **emissivity**. A typical value for aluminum (roughly polished) is 0.18 and for plastics values of 0.84...0.95 are typical. IR thermometers use the radiation flux between the sensitive element in the sensor and the object of interest, given by the equation

$$q = \epsilon_1 * \alpha_1 * T_1^4 * \sigma * A_1 * F_{a-b} - \epsilon_2 * T_2^4 * \sigma * A_2$$

Where:

ϵ_1 and ϵ_2 are the emissivity of the two objects,

α_1 is the absorptivity of the sensor (in this case),

σ is the Stefan-Boltzmann constant,

A_1 and A_2 are the surface areas involved in the radiation heat transfer,

F_{a-b} is the shape factor,

T_1 and T_2 are known temperature of the sensor die (measured with specially integrated and calibrated element) and the object temperature that we need.

Note that these are all in Kelvin, heat exchange knows only physics.

When a body with low emissivity (such as aluminum) is involved in this heat transfer, the portion of the radiation incident to the sensor element that really comes from the object of interest decreases – and the reflected environmental IR emissions take place. (This is all for bodies with zero transparency in the IR band.) The IR thermometer is calibrated to stay within specified accuracy – but it has no way to separate the incoming IR radiation into real object and reflected environmental part. Therefore, measuring objects with low emissivity is a very sophisticated issue and infra-red measurements of such materials are a specialized field.

What can be done to solve that problem? Look at paintings – for example, oil paints are likely to have emissivity of 0.85...0.95 – but keep in mind that the stability of the paint emissivity has inevitable impact on measurements.

It is also a good point to keep in mind that not everything that looks black is “black” also for IR. For example, even heavily oxidized aluminum has still emissivity as low as 0.30.

MLX90614

Single and dual zone IR sensor in TO39
Datasheet



How high is enough? Not an easy question – but, in all cases the closer you need to get to the real object temperature the higher the needed emissivity will be, of course.

With the real-life emissivity values the environmental IR comes into play via the reflectivity of the object (the sum of Emissivity, Reflectivity and Absorptivity gives 1.00 for any material). The larger the difference between environmental and object temperature is at given reflectivity (*with an opaque for IR material reflectivity equals 1.00 minus emissivity*) the bigger errors it produces.

After I put the MLX90614 in the dashboard I start getting errors larger than specified, despite the fact that the module was working properly before that. Why?

Any object present in the FOV of the module provides IR signal. It is actually possible to introduce error in the measurements if the module is attached to the dashboard with an opening that enters the FOV. In that case portion of the dashboard opening will introduce IR signal in conjunction with constraining the effective FOV and thus compromising specified accuracy. Relevant opening that takes in account the FOV is a must for accurate measurements. Note that the basic FOV specification takes 50% of IR signal as threshold (in order to define the area, where the measurements are relevant), while the entire FOV at lower level is capable of introducing lateral IR signal under many conditions.

When a hot (cold) air stream hits my MLX90614 some error adds to the measured temperature I read.

What is it?

IR sensors are inherently sensitive to difference in temperatures between the sensitive element and everything incident to that element. As a matter of fact, this element is not the sensor package, but the sensor die inside. Therefore, a thermal gradient over the sensor package will inevitably result in additional IR flux between the sensor package and the sensor die. This is real optical signal that cannot be segregated from the target IR signal and will add errors to the measured temperature.

Thermal gradients with impact of that kind are likely to appear during transient conditions. The sensor used is developed with care about sensitivity to this kind of lateral phenomena, but their nature demands some care when choosing place to use the MLX90614 in order to make them negligible.

I measure human body temperature and I often get measurements that significantly differ from the +37°C I expect.

IR measurements are true surface temperature measurements. In many applications this means that the actual temperature measured by an IR thermometer will be temperature of the clothing and not the skin temperature. Emissivity (explained first in this section) is another issue with clothes that has to be considered. There is also the simple chance that the measured temperature is adequate – for example, in a cold winter human hand can appear at temperatures not too close to the well-known +37°C.

I consider using MLX90614AAA to measure temperature within car compartment, but I am embarrassed about the Sun light that may hit the module. Is it a significant issue?

Special care is taken to cut off the visible light spectra as well as the NIR (near IR) before it reaches the sensitive sensor die. Even more, the glass (in most cases) is not transparent to the IR radiation used by the MLX90614. Glass has temperature and really high emissivity in most cases – it is “black” for IR of interest. Overall, Sun behind a window is most likely to introduce relatively small errors. Why is it not completely eliminated after all? Even visible light partially absorbed in the filter of the sensor has some heating potential and there is no way that the sensor die will be “blind” for that heating right in front of it.

MLX90614

Single and dual zone IR sensor in TO39
Datasheet

6 Package, IC handling and assembly

6.1 Package information

The MLX90614 is packaged in an industry standard TO39 can.

6.1.1 Package MLX90614xxA

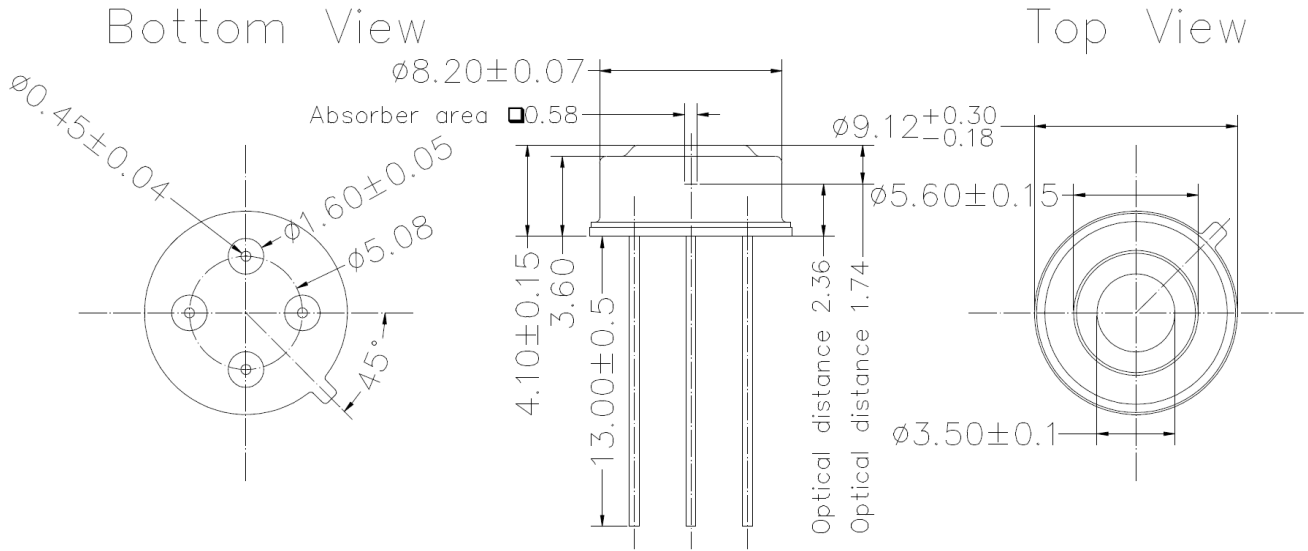

Figure 41 – Mechanical drawing of MLX90614xxA

6.1.2 Package MLX90614xCC

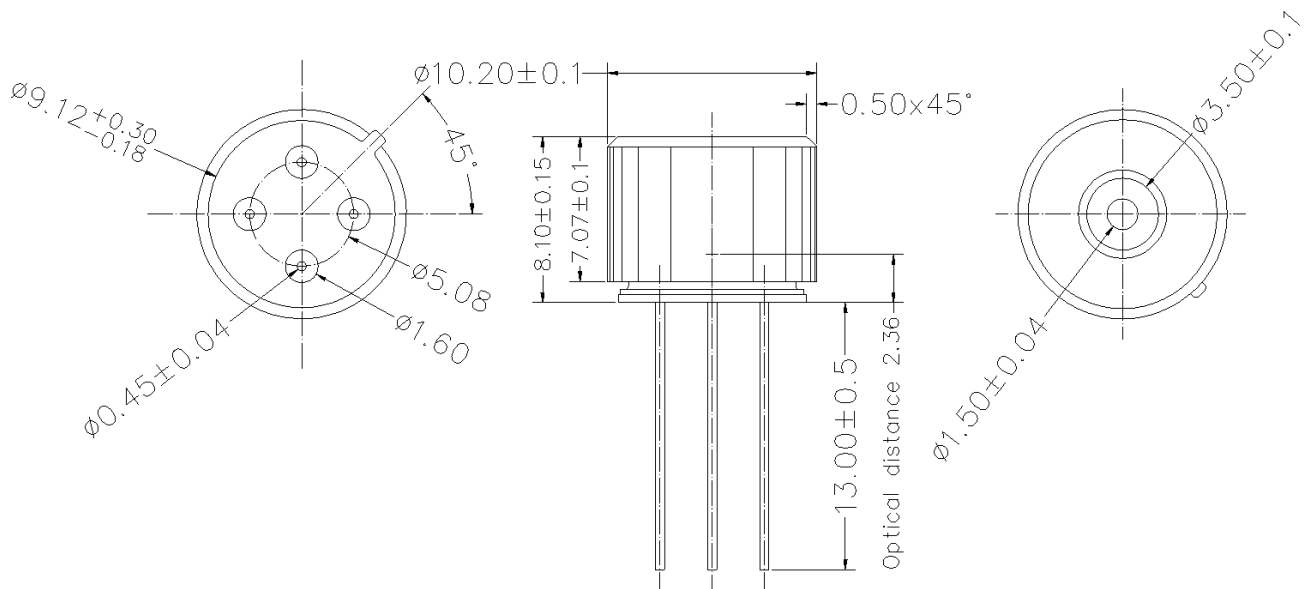

Figure 42 – Mechanical drawing of MLX90614xCC

MLX90614

Single and dual zone IR sensor in TO39
Datasheet

6.1.5 Package MLX90614xCI

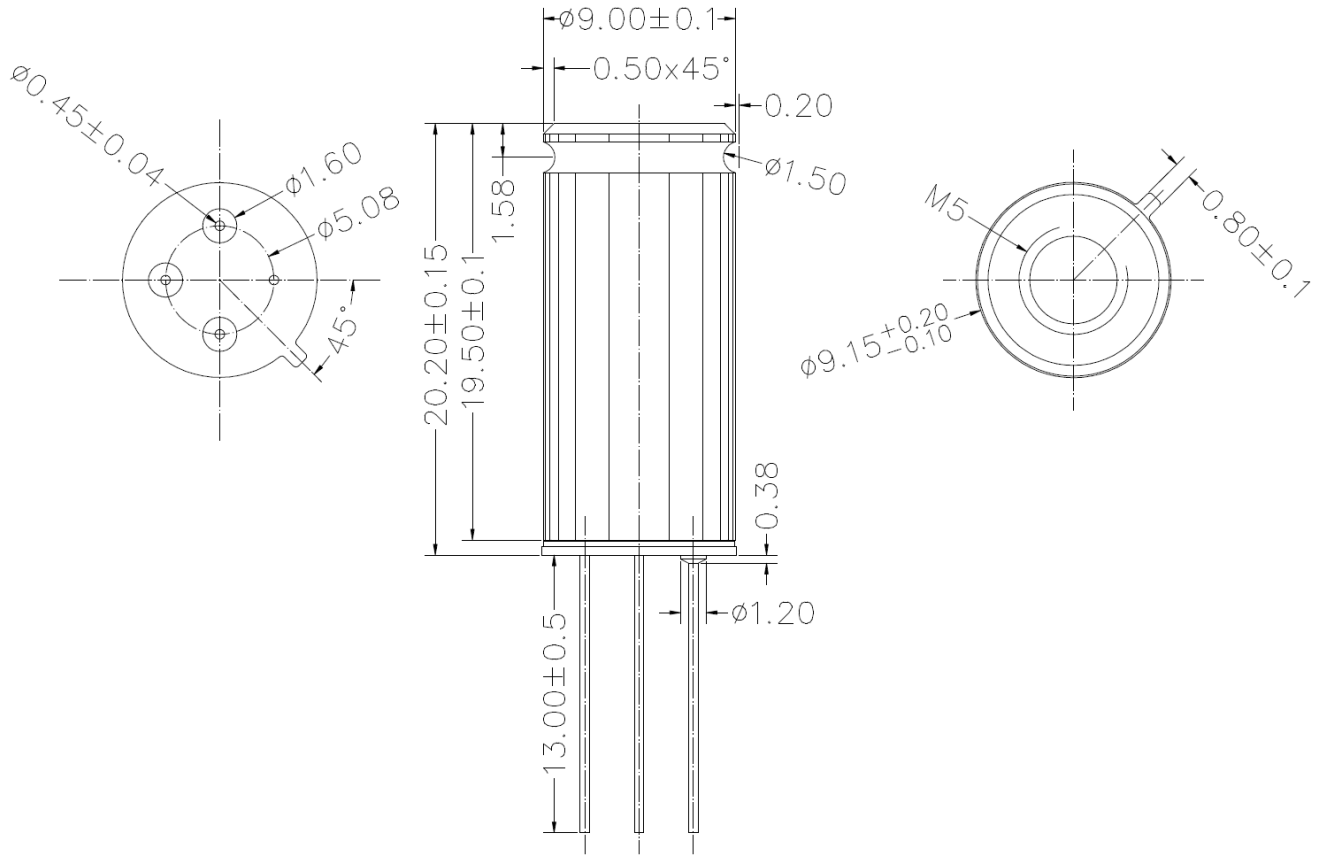

Figure 45 – Mechanical drawing of MLX90614xCI

6.1.6 Package MLX90614xCK

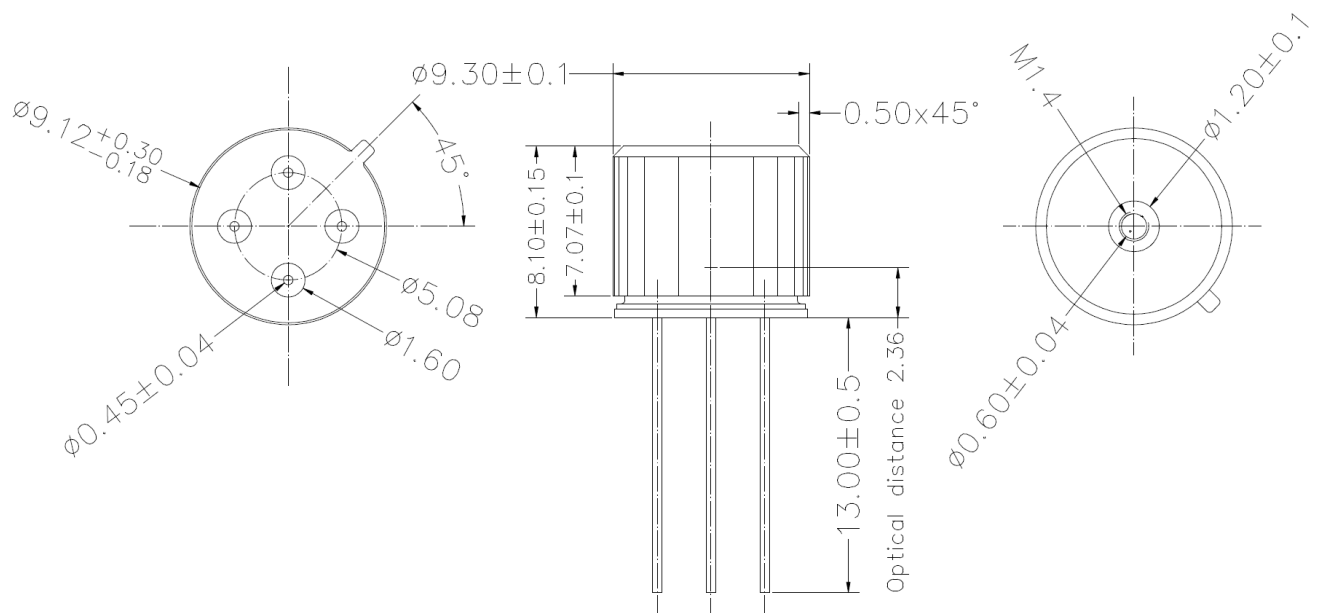

Figure 46 – Mechanical drawing of MLX90614xCK

MLX90614

Single and dual zone IR sensor in TO39
Datasheet

6.1.7 Package marking

The MLX90614 is laser marked with 10 symbols as follows.

Supply / Accuracy	Zones / TGC	Package option	xxxxxxx	Laser marking
				7 digits LOT number
		A		Standard package - 90° FOV
		B		Reserved
		C		35° FOV
		D / E		Reserved
		F		10° FOV (Fresnel lens)
		G		Reserved
		H		12° FOV (refractive lens)
		I		5° FOV
		K		13° FOV
	A	Single zone		
	B	Dual zone		
	C	Gradinet compensated		
A	VDD = 5V			
B	VDD = 3V			
C	Reserved			
D	VDD = 3V - Medical grade			

Table 20 – Laser marking convention

Example: “ACC9307308” – Device type MLX90614ACC from LOT 93073X08, with Thermal Gradient Compensation.

6.2 Storage and handling of ICs

Electronic semiconductor products are sensitive to Electro Static Discharge (ESD). The component assembly shall be handled in EPA (Electrostatic Protected Area) as per ANSI S20.20

For more information refer to Melexis [Guidelines for storage and handling of plastic encapsulated ICs](#) ⁽²⁾

6.3 Assembly of TO packaged ICs

Pin handling: According to MIL STD 883-2 Method 2009.4 / 3.3.5 Leads / b. :
Terminal leads must be:

- Intact
- Aligned in their normal location
- Free of sharp or unspecified bends
- Twisted no more than 20° from the normal lead plane.

For Through Hole Devices (THD), the applicable soldering methods are reflow, wave, selective wave and robot point-to-point. THD lead pre-forming (cutting and/or bending) is applicable under strict compliance with Melexis [Guidelines for lead forming of SIP Hall Sensors](#) ⁽²⁾.

The thermal shocks on the glass beads must be limited as much as possible. Therefore, Melexis recommends the use of robotic soldering.

² www.melexis.com/ic-handling-and-assembly

MLX90614

Single and dual zone IR sensor in TO39
 Datasheet

Melexis products soldering on PCB should be conducted according to the requirements of IPC/JEDEC and J-STD-001. Solder quality acceptance should follow the requirements of IPC-A-610.

Our products are classified and qualified regarding soldering technology, solderability and moisture sensitivity level according to following test methods:

Wave Soldering THD's (Through Hole Devices)

- EIA/JEDEC JESD22-B106 and EN60749-15
 Resistance to soldering temperature for through-hole mounted devices

Iron Soldering THD's (Through Hole Devices)

- EN60749-15
 Resistance to soldering temperature for through-hole mounted devices

Solderability THD's (Through Hole Devices)

- EIA/JEDEC JESD22-B102 and EN60749-21
 Solderability

For all soldering technologies deviating from above mentioned standard conditions (regarding peak temperature, temperature gradient, temperature profile etc.) additional classification and qualification tests have to be agreed upon with Melexis.

For other specific process, contact Melexis via www.melexis.com/technical-inquiry

6.4 Environment and sustainability

Melexis is contributing to global environmental conservation by promoting non-hazardous solutions. For more information on our environmental policy and declarations (RoHS, REACH...) visit www.melexis.com/environmental-forms-and-declarations

6.5 Packing information

6.5.1 Packing method

Sensors are stored in tubes and the tubes are put in the box

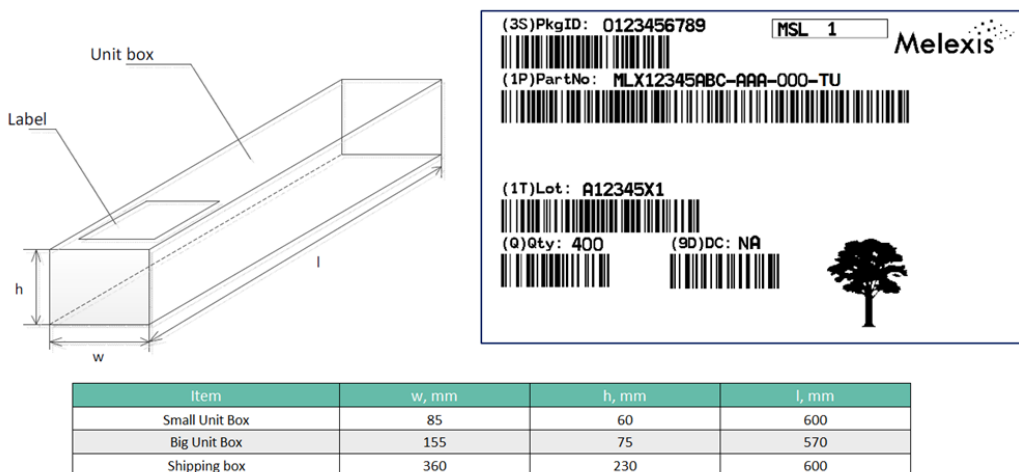

Figure 47 – Box for tubes – 11 tubes or less per box (small or big)

MLX90614

Single and dual zone IR sensor in TO39
Datasheet

6.5.2 Packing style

There are two variants for packing style depending on the used packing method boxes

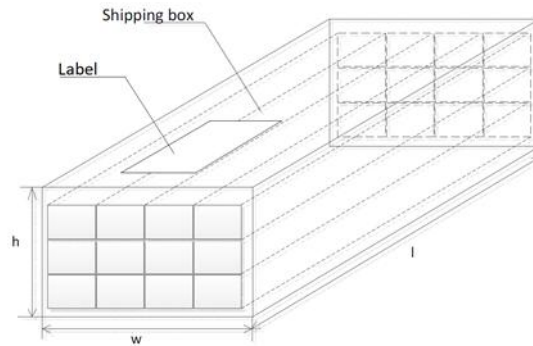

Figure 48 – Variant 1: 12 small boxes in one shipping box

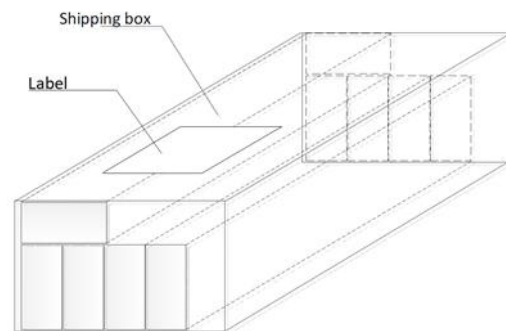

Figure 49 – Variant 2: 5 big boxes in one shipping box

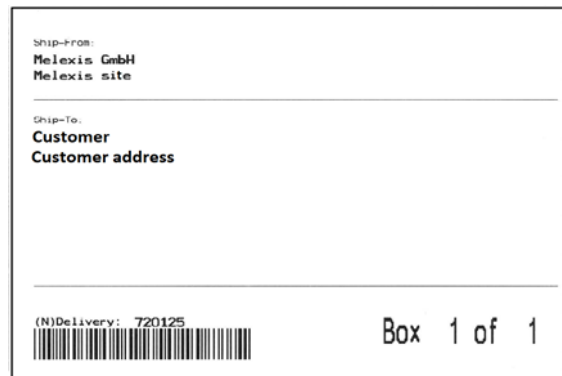

Figure 50 – Shipping box label

7 Glossary of terms & references

7.1 Glossary

Term	Description
ADC	A nalog to D igital C onverter
DSP	D igital S ignal P rocessing
DSP	D igital S ignal P rocessing
EMC	E lectro M agnetic C ompatibility
ESD	E lectro S tatic D ischarge
FIR	F ar I nfra- R ed
FOV	F ield O f V iew
HFO	H igh F requency O scillator (RC type)
IR data	I nfra R ed data (raw data from ADC proportional to IR energy received by the sensor)
LSb	L east S ignificant b it
LSB	L east S ignificant B yte
MD	M aster D evice
MSb	M ost S ignificant b it
MSB	M ost S ignificant B yte
N/A	N ot A pplicable
PEC	P acked E rror C ode
POR	P ower O n R eset
PTAT	P roportional T o A bsolute T emperature sensor (package temperature)
SCL	S erial C lock
SD	S lave D evice
SDA	S erial D ata
Ta	A mbient T emperature – the temperature of the TO39 package
TBD	T o B e D efined
TGC	T emperature G radient C oefficient / C ompensation
To	O bject T emperature, 'seen' or measured by the IR sensor

Table 21 – Glossary

MLX90614

Single and dual zone IR sensor in TO39
Datasheet



7.2 List of tables

Table 1 – Product codes (limited version listed out of many combinations).....	2
Table 2 – TO39 package pins description	6
Table 3 – Absolute Maximum Ratings	7
Table 4 – Electrical operating conditions	8
Table 5 – Electrical specifications Axx version	8
Table 6 – Electrical operating conditions	9
Table 7 – Electrical specification – Bxx and Dxx versions	9
Table 8 – EEPROM table – size 32x16.....	12
Table 9 – Configuration register 1	13
Table 10 – PWM control bits	14
Table 11 – output settling time as a function if the filter settings	14
Table 12 – factory default IIR and FIR configuration, settling time and typical noise.....	15
Table 13 – FIR and IIR settings.....	15
Table 14 – RAM table – size 32x16.....	16
Table 15 – SMBus commands.....	19
Table 16 – Flags	20
Table 17 – PWM configuration table.....	23
Table 18 – PWM timing depending on the PWM mode	23
Table 19 – FOV summary.....	37
Table 20 – Laser marking convention.....	50
Table 21 – Glossary.....	53

7.3 List of figures

Figure 1 – MLX90614 overview and pin description	6
Figure 2 – Block diagram	11
Figure 3 – SMBus packed element key	18
Figure 4 – START, Repeated START and STOP condition in read command only	18
Figure 5 – Recommended timing on SMBus	19
Figure 6 – SMBus read word (default SA = 0x5A, read RAM = 0x07, result = 0x3AD2, PEC = 0x30)	20
Figure 7 – SMBus write word (default SA = 0x5A, write EEPROM = 0x02, data = 0xC807, PEC = 0x48)	20
Figure 8 – Go to sleep mode command format (default SA = 0x5A, command = 0xFF, PEC = 0xE8)	20
Figure 9 – Read flags command format (default SA = 0x5A, typical flags data = 0x0010, PEC = 0xED)	20
Figure 10 – Exit sleep mode (Wake Up Request)	21
Figure 11 – SMBus timing specification and definition	22
Figure 12 – Undershoot of SCL line due to on chip synthesized Zener diode (5V versions only)	22
Figure 13 – PWM timing single (above) and extended mode (below)	23
Figure 14 – PWM example – single mode	24
Figure 15 – PWM repetition number, PWM control [8:4] = 1 resulting in 1 data + 2 times repetition	25
Figure 16 – Example: extended PWM mode readings – sensor 1 above and sensor 2 below	25
Figure 17 – PWM example - extended mode	27
Figure 18 – Switching from PWM mode to SMBus	27
Figure 19 – Thermal relay: PWM (SDA) pin versus Tobj	28
Figure 20 – Software flow	31
Figure 21 – Accuracy of MLX90614 (Ta, To) except for xCK type	33
Figure 22 – Accuracy of MLX90614xCK (Ta, To) only	34
Figure 23 – Medical accuracy	35
Figure 24 – Typical Ta dependence from supply voltage	36
Figure 25 – Typical To dependence from supply voltage (practically the same as Ta dependence error)	36
Figure 26 – Typical To error after compensation of VDD dependence	37
Figure 27 – Field Of View (FOV) measurement concept	37
Figure 28 – Typical FOV of MLX90614xAA	38
Figure 29 – Typical FOV of MLX90614xBA, Zone 1 & 2 identification relative to the alignment tab	38
Figure 30 – Typical FOV of MLX90614xCC	38
Figure 31 – Typical FOV of MLX90614xCF	39
Figure 32 – Typical FOV of MLX90614xCH	39
Figure 33 – Typical FOV of MLX90614xCI	40
Figure 34 – Typical FOV of MLX90614xCK	40
Figure 35 – MLX90614 electrical connections in SMBus communication	41
Figure 36 – Use of multiple MLX90614 devices in SMBus network	41
Figure 37 – Connection of MLX90614 for PWM output mode	42
Figure 38 – PWM output with SMBus available	42
Figure 39 – Thermal alert / thermostat applications examples	42
Figure 40 – High voltage regulator implementation	43

MLX90614

Single and dual zone IR sensor in TO39
Datasheet



Figure 41 – Mechanical drawing of MLX90614AxA.....	47
Figure 42 – Mechanical drawing of MLX90614xCC	47
Figure 43 – Mechanical drawing of MLX90614xCF	48
Figure 44 – Mechanical drawing of MLX90614xCH	48
Figure 45 – Mechanical drawing of MLX90614xCI	49
Figure 46 – Mechanical drawing of MLX90614xCK	49
Figure 47 – Box for tubes – 11 tubes or less per box (small or big)	51
Figure 48 – Variant 1: 12 small boxes in one shipping box	52
Figure 49 – Variant 2: 5 big boxes in one shipping box.....	52
Figure 50 – Shipping box label.....	52

MLX90614

Single and dual zone IR sensor in TO39
Datasheet



7.4 References

[1] **System Management Bus (SMBus) Specification** Version 2.0 August 3, 2000
SBS Implementers Forum Copyright. 1994, 1995, 1998, 2000
Duracell, Inc., Energizer Power Systems, Inc., Fujitsu, Ltd., Intel Corporation, Linear Technology
Inc., Maxim Integrated Products, Mitsubishi Electric Semiconductor Company, PowerSmart, Inc.,
Toshiba Battery Co. Ltd., Unitrode Corporation, USAR Systems, Inc.

8 Disclaimer

The content of this document is believed to be correct and accurate. However, the content of this document is furnished "as is" for informational use only and no representation, nor warranty is provided by Melexis about its accuracy, nor about the results of its implementation. Melexis assumes no responsibility or liability for any errors or inaccuracies that may appear in this document. Customer will follow the practices contained in this document under its sole responsibility. This documentation is in fact provided without warranty, term, or condition of any kind, either implied or expressed, including but not limited to warranties of merchantability, satisfactory quality, non-infringement, and fitness for purpose. Melexis, its employees and agents and its affiliates' and their employees and agents will not be responsible for any loss, however arising, from the use of, or reliance on this document. Notwithstanding the foregoing, contractual obligations expressly undertaken in writing by Melexis prevail over this disclaimer.

This document is subject to change without notice, and should not be construed as a commitment by Melexis. Therefore, before placing orders or prior to designing the product into a system, users or any third party should obtain the latest version of the relevant information.

Users or any third party must determine the suitability of the product described in this document for its application, including the level of reliability required and determine whether it is fit for a particular purpose.

This document as well as the product here described may be subject to export control regulations. Be aware that export might require a prior authorization from competent authorities. The product is not designed, authorized or warranted to be suitable in applications requiring extended temperature range and/or unusual environmental requirements. High reliability applications, such as medical life-support or life-sustaining equipment or avionics application are specifically excluded by Melexis. The product may not be used for the following applications subject to export control regulations: the development, production, processing, operation, maintenance, storage, recognition or proliferation of:

- 1. chemical, biological or nuclear weapons, or for the development, production, maintenance or storage of missiles for such weapons;*
- 2. civil firearms, including spare parts or ammunition for such arms;*
- 3. defense related products, or other material for military use or for law enforcement;*
- 4. any applications that, alone or in combination with other goods, substances or organisms could cause serious harm to persons or goods and that can be used as a means of violence in an armed conflict or any similar violent situation.*

No license nor any other right or interest is granted to any of Melexis' or third party's intellectual property rights.

If this document is marked "restricted" or with similar words, or if in any case the content of this document is to be reasonably understood as being confidential, the recipient of this document shall not communicate, nor disclose to any third party, any part of the document without Melexis' express written consent. The recipient shall take all necessary measures to apply and preserve the confidential character of the document. In particular, the recipient shall (i) hold document in confidence with at least the same degree of care by which it maintains the confidentiality of its own proprietary and confidential information, but no less than reasonable care; (ii) restrict the disclosure of the document solely to its employees for the purpose for which this document was received, on a strictly need to know basis and providing that such persons to whom the document is disclosed are bound by confidentiality terms substantially similar to those in this disclaimer; (iii) use the document only in connection with the purpose for which this document was received, and reproduce document only to the extent necessary for such purposes; (iv) not use the document for commercial purposes or to the detriment of Melexis or its customers. The confidentiality obligations set forth in this disclaimer will have indefinite duration and, in any case, they will be effective for no less than 10 years from the receipt of this document.

This disclaimer will be governed by and construed in accordance with Belgian law and any disputes relating to this disclaimer will be subject to the exclusive jurisdiction of the courts of Brussels, Belgium.

The invalidity or ineffectiveness of any of the provisions of this disclaimer does not affect the validity or effectiveness of the other provisions.

The previous versions of this document are repealed.

Melexis © - No part of this document may be reproduced without the prior written consent of Melexis. (2026)

IATF 16949 and ISO 14001 Certified

For the latest revision of this document, visit <http://www.melexis.com/MLX90614>
Happy to help you! www.melexis.com/contact