

## Features and Benefits

- 16-bit Digital Output for magnetic and temperature data
- Three Wake-up on change / Interrupt modes
- Data Ready output for  $\mu$ C synchronization
- Built-in chip temperature compensation
- Runtime selectable modes (on-the-fly)
- Integrated configurable digital filter
- Magnetic Ranges  $\pm 5\text{mT}$  ( $0.15\mu\text{T/LSB}$ ) and  $\pm 50\text{mT}^1$  ( $1.5\mu\text{T/LSB}$ )
- Individually selectable magnetic axes
- Three user selectable configurations (Low Current, Low Noise, High Range)
- I<sup>2</sup>C compatible with 0.1MHz, 0.4MHz & 1.0MHz
- Two selectable I<sup>2</sup>C slave addresses in one device
- Average consumption of  $3\mu\text{A}$  for X or Y and  $4.3\mu\text{A}$  for Z at 10Hz in single measurement mode
- Average consumption of  $10\mu\text{A}$  for X, Y and Z at 10Hz in single measurement mode
- Power Down mode  $0.7\mu\text{A}$
- Wide supply voltage from 1.7V to 3.6V
- Ambient temperature range from  $-40^\circ\text{C}$  to  $105^\circ\text{C}$
- UTDFN-6 (LD) package: RoHS, Green and Halogen free compliant (2mm x 1.5mm x 0.4mm)

## Application Examples

- PC peripheral – Mouse roller
- Gaming – Joystick, D-pads & Trigger buttons
- Wearables – Smart watch digital crown & bezel
- Battery powered tools – Hairdryer & drill trigger
- White goods – Smart knob & liquid levels
- Industrial – Linear & pneumatic actuators
- Smart home – HMI thermostat & electronic lock
- Home security – Door/window opening detection

## Description

MLX90394 is a 3-axis magnetometer suitable for a myriad of position sensors applications using Triaxis® Hall Technology. The device, especially designed for micropower applications, measures magnetic fields along the 3-axis (X, Y & Z). Those measurements and the IC temperature are converted into 16-bit words which are transferred over an I<sup>2</sup>C communication channel. Measurements can be made upon request or continuously with selectable refresh rates.

MLX90394 offers superb noise performance despite its small 6-pin package. It does all that while keeping current consumption low for multiple settings and configurations.

MLX90394's wake-up modes allow the user to put their entire system in deep sleep, until the IC detects a magnetic field change on the selected axes either versus an initial measurement (Static Delta), or previous measurement (Dynamic Delta), or a predefined absolute threshold (Absolute). In this way both busy as well as slowly drifting magnetic fields can be registered, while the device automatically toggles between active and sleep mode.

The MLX90394 has synchronization options through an interrupt pin and 2x I<sup>2</sup>C addresses (per device) by clever wiring. Furthermore, its available in 4 versions, to offer more variety in I<sup>2</sup>C address options. In total 8x pre-programmed MLX90394 can be placed on a single I<sup>2</sup>C bus.



Figure 1 UTDFN-6

<sup>1</sup>  $\pm 200\text{mT}$  in Z direction available on specific request

# Contents

<b>Features and Benefits</b> .....	<b>1</b>
<b>Application Examples</b> .....	<b>1</b>
<b>Description</b> .....	<b>1</b>
<b>Contents</b> .....	<b>2</b>
<b>1. Ordering information</b> .....	<b>3</b>
<b>2. Glossary of terms</b> .....	<b>4</b>
<b>3. Pins Description and Block diagram</b> .....	<b>5</b>
3.1. Pins description .....	5
3.2. Block Diagram .....	5
<b>4. Conditions and Specifications</b> .....	<b>6</b>
4.1. Absolute Maximum Ratings (AMR) .....	6
4.2. Operating Conditions .....	6
4.2.1. General Operating Conditions .....	6
4.2.2. Electrical Operating Conditions .....	6
4.2.3. Thermal Characteristics .....	6
4.2.4. Magnetic Operating Conditions .....	6
4.3. Electrical Specifications .....	7
4.4. Magnetic Specifications .....	9
4.5. Timing Specifications .....	13
<b>5. Functional Description</b> .....	<b>15</b>
5.1. Device Configuration for Magnetic measurements .....	15
5.2. Configuration of SDA and INTB pin function .....	15
5.3. Operating Modes .....	17
5.3.1. Single measurement mode .....	17
5.3.2. Continuous measurement Mode .....	18
5.3.3. Wake-up On Change Mode .....	20
5.3.4. Power Down (Deep Sleep) .....	23
5.3.5. Magnetic Sensor Overflow .....	23
5.4. Output protocol (I <sup>2</sup> C) description .....	23
5.4.1. Command implementation .....	23
5.5. Memory items description .....	25
5.5.1. Memory Structure .....	25
5.5.2. I/O registers description .....	26
5.6. Flowchart .....	30
<b>6. Application Information</b> .....	<b>31</b>
6.1. Recommended Application Diagram .....	31
<b>7. Package, IC handling and assembly</b> .....	<b>33</b>
7.1. Package information .....	33
7.1.1. Dimensions .....	33
7.1.2. Sensing element location and field direction .....	33
7.1.3. UTDFN6 Package Marking .....	34
7.2. Storage and handling of plastic encapsulated ICs .....	35
7.3. Assembly of encapsulated ICs .....	35
7.4. Environment and sustainability .....	35
<b>8. References</b> .....	<b>36</b>
8.1. List of figures .....	36
8.2. List of tables .....	37
<b>9. Disclaimer</b> .....	<b>38</b>

## 1. Ordering information

Ordering Code	Temperature	Package	Range	Output	Packing
MLX90394RLD-AAA-000-RE	-40°C to 105°C	UTDFN-6 1.5x2	±5mT, ±50mT	I <sup>2</sup> C (0x10 / 0x11)	Reel
MLX90394RLD-AAA-001-RE	-40°C to 105°C	UTDFN-6 1.5x2	±5mT, ±50mT	I <sup>2</sup> C (0x60 / 0x61)	Reel
MLX90394RLD-AAA-002-RE	-40°C to 105°C	UTDFN-6 1.5x2	±5mT, ±50mT	I <sup>2</sup> C (0x68 / 0x69)	Reel
MLX90394RLD-AAA-003-RE	-40°C to 105°C	UTDFN-6 1.5x2	±5mT, ±50mT	I <sup>2</sup> C (0x6A / 0x6B)	Reel

*Table 1 – Ordering codes*

**Legend:**

### MLX90394RLD-AAA-000-RE

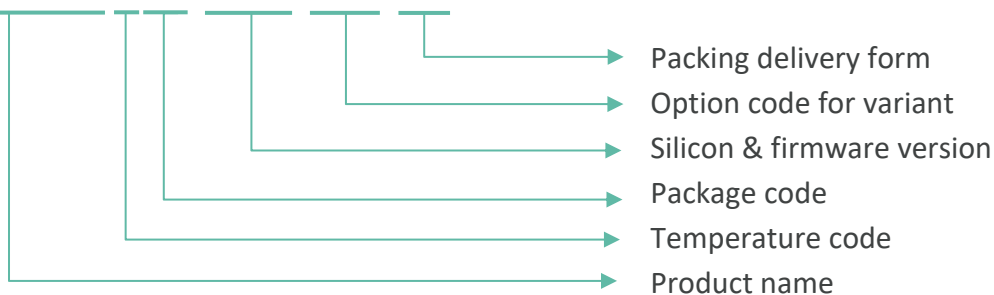

## 2. Glossary of terms

Term	Description
NC	Not Connected
ADC	Analog-to-digital converter
LSB	Least significant bit
MSB	Most significant bit
Gauss (G)	Units for magnetic flux density – 1mT = 10G
RMS	Root mean square
POR	Power On reset
NV	Non-volatile
DSP	Digital signal processing
WOC	Wake-up On Change

## 3. Pins Description and Block diagram

### 3.1. Pins description

Pin #	Pin Name	Pin Description	Function
1	SDA	Digital Input/Output	I <sup>2</sup> C Bus Data Input/Output, WOC Interrupt Output, Synchronization Output
2	SCL	Digital Input / Output	I <sup>2</sup> C Bus Clock
3	Not used	Ground	Sense GND internally connected to pin #4 through the die pad <sup>2</sup>
4	GND	Ground	Ground
5	VDD	Supply	Supply
6	INTB	Digital Input/Output	I <sup>2</sup> C Bus Data Input/Output, WOC Interrupt Output, Synchronization Output

Table 2 – Pin description

### 3.2. Block Diagram

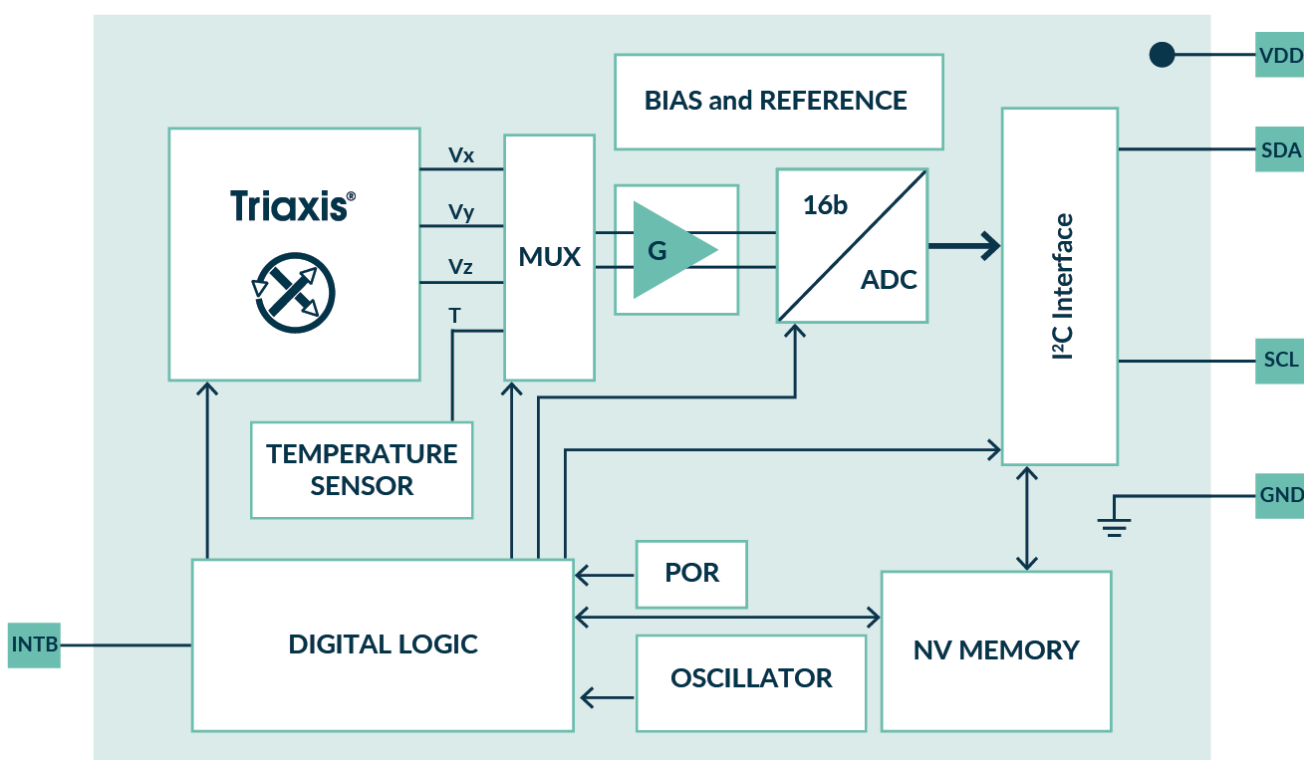

Figure 2: IC block diagram

<sup>2</sup> This pin has to be treated as having GND potential and must be either left floating or connected to pin #4

## 4. Conditions and Specifications

### 4.1. Absolute Maximum Ratings (AMR)

Parameter	Symbol	Min.	Typ.	Max.	Unit	Conditions
Supply Voltage	V <sub>DD</sub>	-0.3	-	4	V	Room temp, <48h
Output voltage	V <sub>SDA</sub> , V <sub>SCL</sub> , V <sub>INTB</sub>	-0.3	-	4	V	Room temp, <48h
ESD HBM (all pins)		-2	-	2	kV	AEC-Q100-002
ESD CDM (all pins)		-500	-	500	V	AEC-Q100-011
Junction Temperature	T <sub>JUNC</sub>	-	-	125	°C	

Table 3– Absolute Maximum Ratings

Exceeding the absolute maximum ratings may cause permanent damage. Exposure to absolute maximum-rated conditions for extended periods may affect device reliability.

### 4.2. Operating Conditions

#### 4.2.1. General Operating Conditions

Parameter	Symbol	Min.	Typ.	Max.	Unit	Conditions
Operating Temperature	T <sub>A</sub>	-40		105	°C	
Storage Temperature	T <sub>storage</sub>	-40		150	°C	

Table 4 – General operating conditions

#### 4.2.2. Electrical Operating Conditions

Parameter	Symbol	Min.	Typ.	Max.	Unit	Conditions
Supply Voltage	V <sub>DD</sub>	1.7	-	3.6	V	

Table 5 – Electrical Operating conditions

#### 4.2.3. Thermal Characteristics

Parameter	Symbol	Typ.	Unit	Conditions
Thermal resistance	R <sub>thja</sub>	230	K/W	Junction to ambient 1s0p board
		40	K/W	Junction to ambient multi layered pcb
Thermal resistance	R <sub>thjc</sub>	3.4	K/W	Junction to case

Table 6 – Thermal Characteristics

#### 4.2.4. Magnetic Operating Conditions<sup>3</sup>

Parameter	Symbol	Min.	Typ.	Max.	Unit	Conditions
Magnetic Flux density	B <sub>z</sub>	-50	-	50	mT	
Magnetic Flux density <sup>4</sup>	B <sub>xy</sub>	-50	-	50	mT	$B_{XY} = \sqrt{B_X^2 + B_Y^2}$
Magnetic Flux density	B <sub>z</sub>	-5	-	5	mT	
Magnetic Flux density <sup>5</sup>	B <sub>xy</sub>	-5	-	5	mT	$B_{XY} = \sqrt{B_X^2 + B_Y^2}$

<sup>3</sup> In case higher fields are required for Z axis (up to 200mT), it is possible to factory program the range accordingly.

<sup>4</sup> The vector sum of X and Y magnetic flux densities should not exceed ±50mT, CONFIG=0,1

<sup>5</sup> The vector sum of X and Y magnetic flux densities should not exceed ±5mT, CONFIG=2

Table 7 – Magnetic Operating conditions

### 4.3. Electrical Specifications

Operating Conditions, V<sub>DD</sub>=1.7V to 3.6V, T<sub>A</sub> = -40°C to 105°C (unless otherwise specified)

Parameter	Symbol	Min.	Typ. <sup>6</sup>	Max.	Unit	Conditions
Power On Reset (rising edge)	V <sub>POR_LH</sub>	1.44	1.5	1.6	V	
Power On Reset (falling edge)	V <sub>POR_HL</sub>	1.35	1.4	1.45	V	
Magnetic axes conversion current	I <sub>DD,CONVXY0</sub>	-	2	2.9	mA	XY axis CONFIG=0
	I <sub>DD,CONVZ0</sub>	-	3	4.5	mA	Z axis CONFIG=0
	I <sub>DD,CONVXY12</sub>	-	2.9	3.8	mA	XY axis CONFIG=1,2
	I <sub>DD,CONVZ12</sub>	-	3.9	5.3	mA	Z axis CONFIG=1,2
Temperature conversion current	I <sub>DD,CONVT</sub>	-	0.89	1.1	mA	
Counting state current	I <sub>DD,CNT</sub>	-	9.5	15	μA	
Digital Signal Processing Current	I <sub>DD,DSP</sub>	-	450	610	μA	T_EN=0
		-	500	660	μA	T_EN=1
Power Down current	I <sub>DD,PD</sub>	-	0.7	2.5	μA	
Average current consumption at 15Hz refresh rate <sup>7</sup>	I <sub>DD,AVG1</sub>	-	29	40	μA	OSR_HALL=0
		-	43	60	μA	OSR_HALL=1 CONFIG=0
Average current consumption at 15Hz polling rate <sup>8</sup>	I <sub>DD,AVG2</sub>	-	15	23	μA	OSR_HALL=0
		-	29	40	μA	OSR_HALL=1 CONFIG=0
Average current consumption at 100Hz refresh rate <sup>7</sup>	I <sub>DD,AVG3</sub>	-	142	200	μA	OSR_HALL=0
		-	238	320	μA	OSR_HALL=1 CONFIG=0
Average current consumption at 100Hz refresh rate <sup>7</sup>	I <sub>DD,AVG4</sub>	-	175	230	μA	OSR_HALL=0
		-	300	400	μA	OSR_HALL=1 CONFIG=1,2
Average current consumption at 10Hz polling rate <sup>8</sup>	I <sub>DD,AVG5</sub>	-	10	15	μA	OSR_HALL=0
		-	19	27	μA	OSR_HALL=1 CONFIG=0
Average current consumption at 10Hz polling rate <sup>9</sup>	I <sub>DD,AVG6</sub>	-	3	6	μA	OSR_HALL=0 CONFIG=0
Average current consumption at 10Hz polling rate <sup>10</sup>	I <sub>DD,AVG7</sub>	-	4.3	7.8	μA	OSR_HALL=0 CONFIG=0

Table 8 Electrical specification

The average current consumption in Continuous measurement mode can be calculated using the following formula:

$$I_{DD} = \frac{T_{Temp} \cdot I_{DD,CONVT} + 2 \cdot T_{XY} \cdot I_{DD,CONVXY} + T_Z \cdot I_{DD,CONVZ} + T_{DSP} \cdot I_{DD,DSP} + T_{Counting} \cdot I_{DD,CNT}}{T_{refresh}}$$

Where T<sub>Temp</sub>, T<sub>XY</sub> and T<sub>Z</sub> are controlled by DIG\_FILT\_HALL\_XY, DIG\_FILT\_HALL\_Z, DIG\_FILT\_TEMP, OSR\_TEMP, OSR\_HALL and T\_EN. T<sub>DSP</sub> can be set according to the timing specification in Table 13. T<sub>Counting</sub> is defined as

$$T_{Counting} = T_{refresh} - (T_{Temp} + 2 \cdot T_{XY} + T_Z + T_{DSP})$$

<sup>6</sup> V<sub>DD</sub>=2.2V, T<sub>A</sub>=35°C

<sup>7</sup> Refresh rate in Continuous measurement mode XYZT, DIG\_FILT\_HALL\_XY=0, DIG\_FILT\_HALL\_Z=1, DIG\_FILT\_TEMP=1, OSR\_TEMP=1, T\_EN=1

<sup>8</sup> Polling rate in Single measurement mode XYZ, DIG\_FILT\_HALL\_XY=0, DIG\_FILT\_HALL\_Z=1, T\_EN=0

<sup>9</sup> Polling rate in Single measurement mode X or Y, DIG\_FILT\_HALL\_XY=0, T\_EN=0

<sup>10</sup> Polling rate in Single measurement mode Z, DIG\_FILT\_HALL\_Z=0, T\_EN=0

In case an axis is not selected for conversion, its respective measurement time is set to 0s. In case the temperature measurement is not enabled (T\_EN=0), then T<sub>Temp</sub> is set to 0s. T<sub>refresh</sub> is the refresh period set by the user.

Parameter	Symbol	Min.	Typ.	Max.	Unit	Conditions
Temperature sensor resolution <sup>11</sup>	TRES	-	50	-	LSB16/°C	
Temperature sensor accuracy	TLIN	-3	-	3	°C	+/-3sigma with respect to 35°C

Table 9 Temperature sensor specification

Parameter <sup>12</sup>	Symbol	Min.	Typ.	Max.	Unit	Conditions
Input Level High	VIH	53	65	71	%VDD	SDA (INTB), SCL
Input Level Low	VIL	37	49	54	%VDD	SDA (INTB), SCL
Input Level Hysteresis	VIHYST	9	16	21	%VDD	SDA (INTB), SCL
Output on resistance	Rdson	-	7.6	15	Ω	SCL
		-	4	7		
Output leakage current		-	-	0.1	μA	SCL, SDA, INTB

Table 10 I<sup>2</sup>C DC Characteristics

Parameter	Symbol	Min.	Typ.	Max.	Unit	Conditions
SDA pull up resistance	R <sub>SDA</sub>	1	-	-	kΩ	When not using SDA pin
INTB pull up resistance	R <sub>INTB</sub>	1	-	-	kΩ	When not using INTB pin

Table 11 I<sup>2</sup>C bus and external connection requirements

<sup>11</sup> The data format is 2's complement with 0 LSB corresponding to 0degC

<sup>12</sup> This specification refers to the sensor and not to the I2C bus

## 4.4. Magnetic Specifications

Operating Conditions,  $V_{DD}=1.7V$  to  $3.6V$ ,  $T_A = -40^{\circ}C$  to  $105^{\circ}C$ , (T)XYZ measurement (unless otherwise specified). All specifications in this chapter are given with +/- 3 sigma.

Parameter	Symbol	Min.	Typ.	Max.	Unit	Conditions
Magnetic sensor measurement range	$B_{RANGE}$	$\pm 43.6$	$\pm 49.13$	$\pm 54.7$	mT	room temperature CONFIG=0,1
Magnetic sensor measurement range	$B_{RANGE}$	$\pm 4.36$	$\pm 4.91$	$\pm 5.47$	mT	room temperature CONFIG=2
Resolution <sup>(13)</sup>		-	16	-	bits	XYZT
Magnetic sensitivity	$SENS_{XYZ}$	1.33	1.5	1.67	$\mu T/LSB$	room temperature, CONFIG=0,1
Magnetic sensitivity	$SENS_{XYZ}$	0.133	0.15	0.167	$\mu T/LSB$	room temperature, CONFIG=2
Sensitivity thermal drift	$SENS_{THD}$	-8	-	8	%	vs. $T_a=35^{\circ}C$
Offset <sup>14</sup>	$B_{OFFSX}$	-550	-	550	$\mu T$	
	$B_{OFFSY}$	-550	-	550		
	$B_{OFFSZ}$	-260	-	260		
Offset thermal drift X-axis <sup>12</sup>		-100	-	100	$\mu T$	vs. $35^{\circ}C$
Offset thermal drift Y-axis		-100	-	100		
Offset thermal drift Z-axis		-100	-	100		
RMS Noise <sup>15</sup>	$N_x, N_y, N_z$	-	40	-	$\mu Trms$	OSR_HALL=0, CONFIG=0
RMS Noise <sup>15</sup>	$N_x, N_y, N_z$	-	28	-	$\mu Trms$	OSR_HALL=1, CONFIG=0
RMS Noise <sup>15</sup>	$N_x, N_y, N_z$	-	11	-	$\mu Trms$	OSR_HALL=0, CONFIG=1
RMS Noise <sup>15</sup>	$N_x, N_y, N_z$	-	6.5	-	$\mu Trms$	OSR_HALL=1, CONFIG=1
RMS Noise <sup>15</sup>	$N_x, N_y, N_z$	-	5.1	-	$\mu Trms$	OSR_HALL=0, CONFIG=2
RMS Noise <sup>15</sup>	$N_x, N_y, N_z$	-	3.5	-	$\mu Trms$	OSR_HALL=1, CONFIG=2
RMS Noise <sup>16</sup>	$N_x, N_y, N_z$	-	0.7	-	$\mu Trms$	OSR_HALL=0, CONFIG=2
RMS Noise <sup>16</sup>	$N_x, N_y, N_z$	-	0.5	-	$\mu Trms$	OSR_HALL=1, CONFIG=2

Table 12 Magnetic Specifications

Note: The RMS noise values for OSR=1 are approximately  $\sqrt{2}$  smaller than at setting OSR=0 for the same configuration and DIG\_FILT\_HALL\_XY and DIG\_FILT\_HALL\_Z settings

<sup>13</sup> The data format is 2's complement

<sup>14</sup> No external magnetic field applied. Verified with device characterization tests in the operating magnetic field range

<sup>15</sup> Room temperature, DIG\_FILT\_HALL\_XY=0, DIG\_FILT\_HALL\_Z=1, DIG\_FILT\_TEMP=1, OSR\_TEMP=1

<sup>16</sup> Room temperature, DIG\_FILT\_HALL\_XY=6, DIG\_FILT\_HALL\_Z=7, DIG\_FILT\_TEMP=1, OSR\_TEMP=1

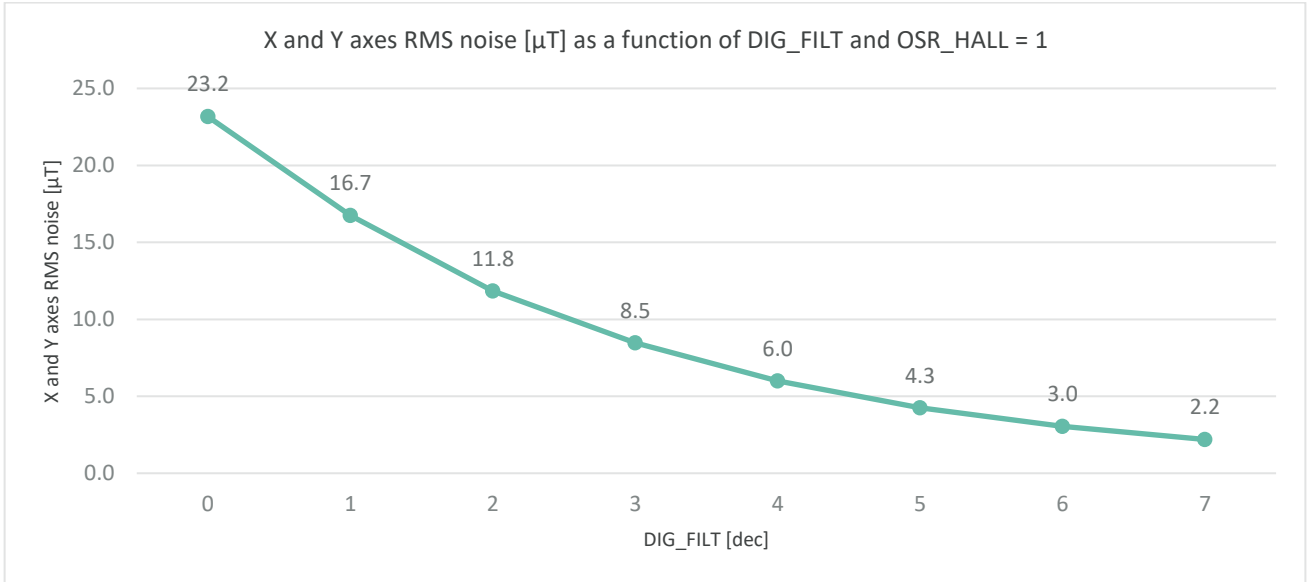

Figure 3 XY axes noise as a function of DIG\_FILT\_HALL\_XY. CONFIG=0

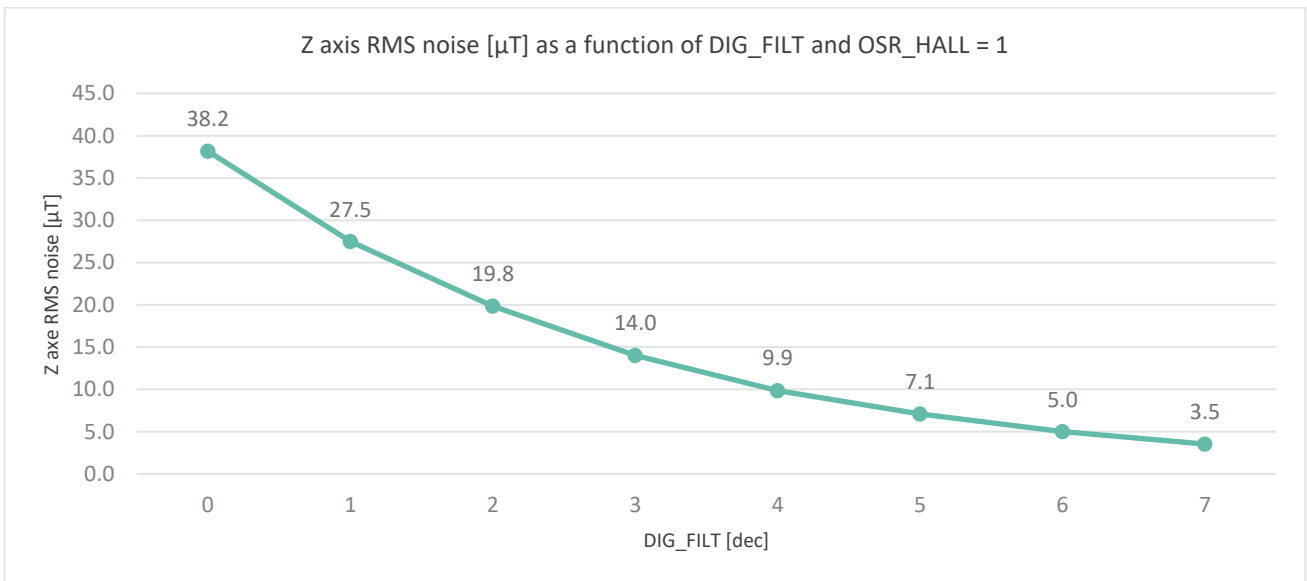

Figure 4 Z axis noise as a function of DIG\_FILT\_HALL\_Z. CONFIG=0

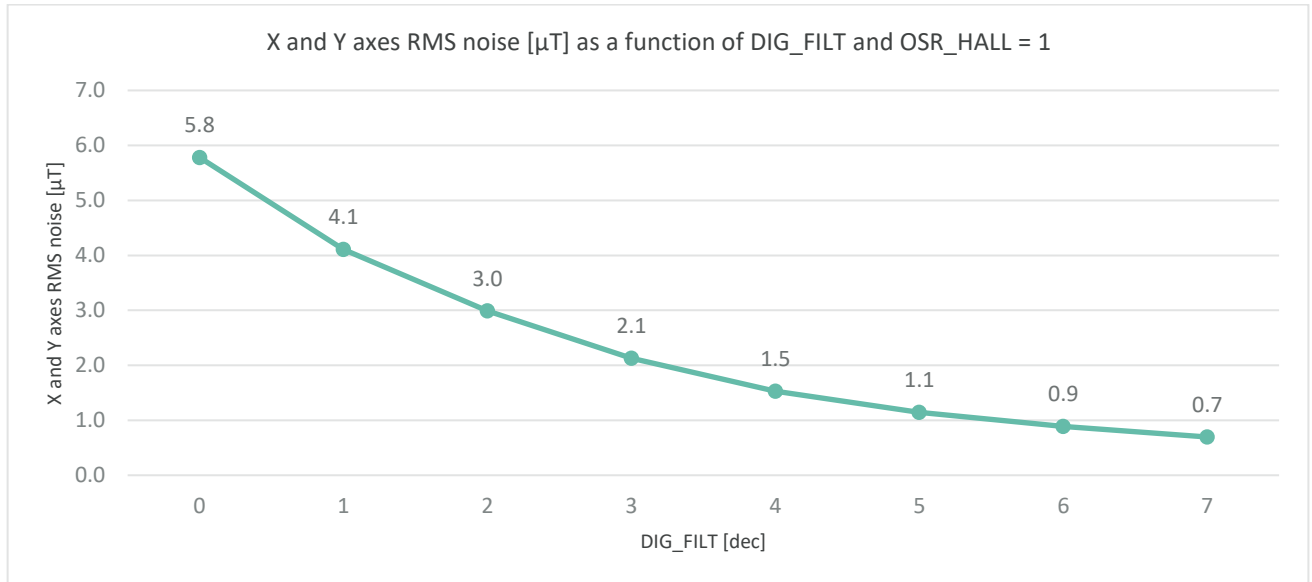

Figure 5 XY axes noise as a function of DIG\_FILTER\_HALL\_XY. CONFIG=1

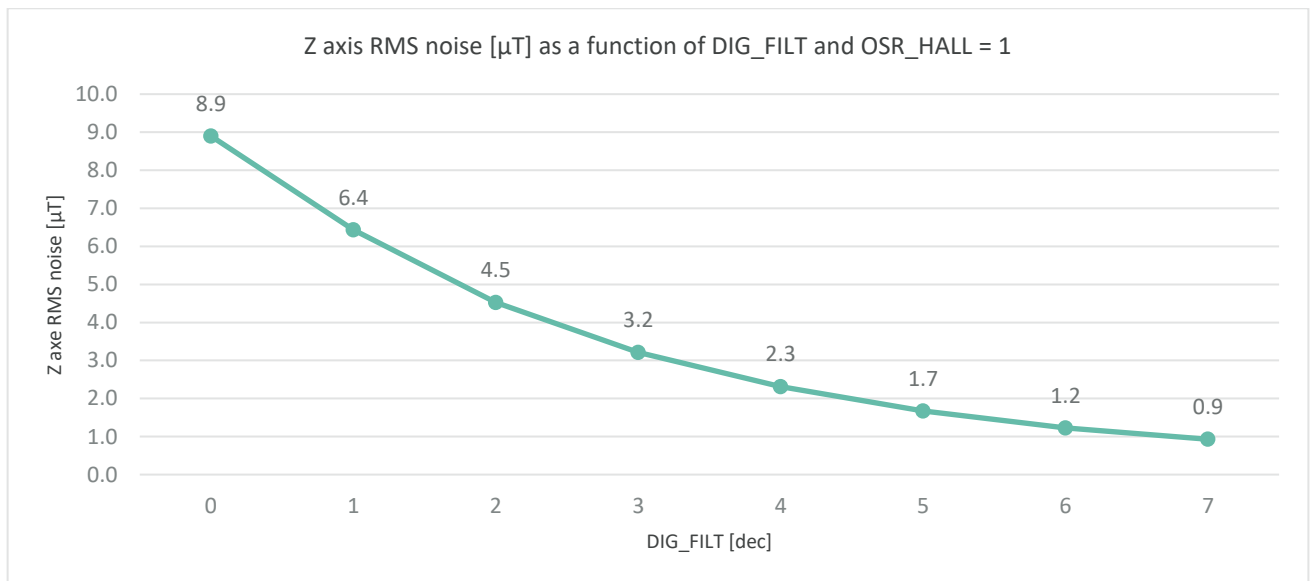

Figure 6 Z axis noise as a function of DIG\_FILTER\_HALL\_Z. CONFIG=1

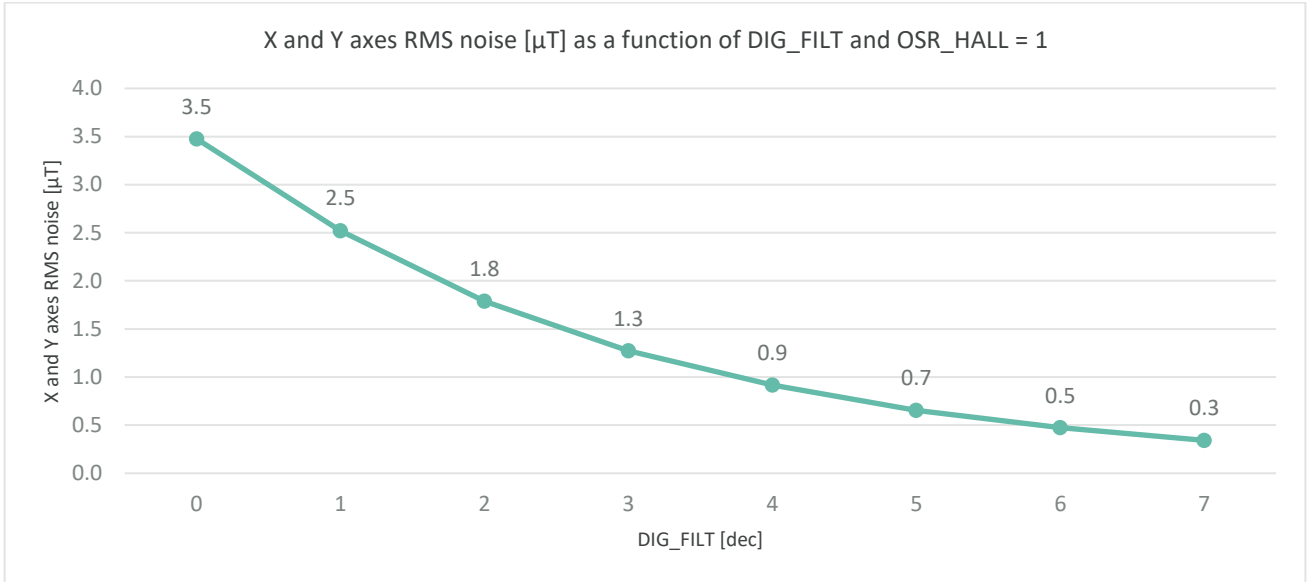

Figure 7 XY axes noise as a function of DIG\_FILTER\_HALL\_XY. CONFIG=2

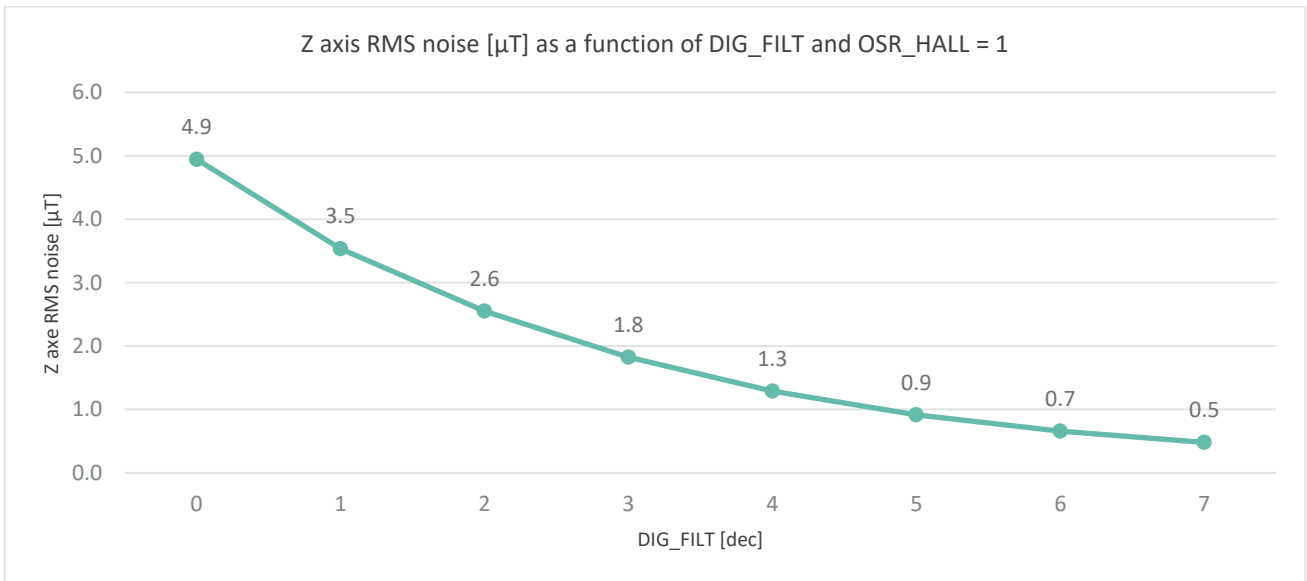

Figure 8 Z axis noise as a function of DIG\_FILTER\_HALL\_Z. CONFIG=2

## 4.5. Timing Specifications

Operating Conditions,  $V_{DD}=1.8V$  to  $3.6V$ ,  $T_A = -40^{\circ}C$  to  $105^{\circ}C$ , (T)XYZ measurement (unless otherwise specified)

Parameter	Symbol	Min.	Typ.	Max.	Unit	Conditions
Output refresh rate <sup>17</sup>	FR <sup>18</sup>	5	100	1400	Hz	
Oscillator trimming accuracy	TOSC_TRIM	-5	0	5	%	
Oscillator Thermal drift	TOSC_THD	-5	0	5	%	
WOC pulse on SCL	WOC_PULSE	14.4	16	17.6	$\mu s$	Default configuration
Magnetic axis conversion time <sup>19</sup>	T <sub>CONVM</sub>	108	113	119	$\mu s$	Time per axis DIG_FILT=0, OSR=0
	T <sub>CONVM</sub>	210	220	232	$\mu s$	Time per axis DIG_FILT=0, OSR=1
	T <sub>CONVM</sub>	1733	1820	1916	$\mu s$	Time per axis DIG_FILT=4, OSR=1
	T <sub>CONVM</sub>	13.1	13.8	14.5	ms	Time per axis DIG_FILT=7, OSR=1
DSP time single axis	T <sub>DSP1</sub>	25.6	27	28.4	$\mu s$	
DSP time two axes	T <sub>DSP2</sub>	47.5	50	52.5	$\mu s$	
DSP time three axes	T <sub>DSP3</sub>	69.3	73	76.7	$\mu s$	
DSP time single axis and temperature	T <sub>DSP1T</sub>	59.8	63	66.2	$\mu s$	
DSP time two axes and temperature	T <sub>DSP2T</sub>	81.7	86	90.3	$\mu s$	
DSP time three axes and temperature	T <sub>DSP3T</sub>	104.5	110	115.3	$\mu s$	
DSP time temperature	T <sub>DSP T</sub>	19	20	21	$\mu s$	
Start-up time	T <sub>Startup</sub>	-	0.15	0.4	ms	From initial reset to Power Down mode. No toggling on INTB pin during Power-up

Table 13 – Timing specifications

<sup>17</sup> FR is defined as the inverse of the period between two sets of measurements. It is relevant for the Continuous measurement and WOC modes and is defined by the parameter MODE[3:0]. FR is adjustable with the following settings: 5Hz, 10Hz, 15Hz, 50Hz, 100Hz, 200Hz, 500Hz, 700Hz, 1000Hz, 1400Hz. The default value in the non-volatile memory is 100Hz.

<sup>18</sup> It is up to the user to make sure that the FR setting corresponds to the time needed to measure the selected axes with their respective filter settings, together with the DSP time, which depends on whether T\_EN is set or reset.

<sup>19</sup> This conversion time is defined as the time to acquire a single axis of the magnetic flux density. When measuring XYZ, they are obtained through time-multiplexing. The conversion time is programmable through DIG\_FILT\_HALL\_XY, DIG\_FILT\_HALL\_Z for magnetic and DIG\_FILT\_TEMP for temperature conversion. The total conversion time is obtained by summing up the magnetic & temperature conversion time.

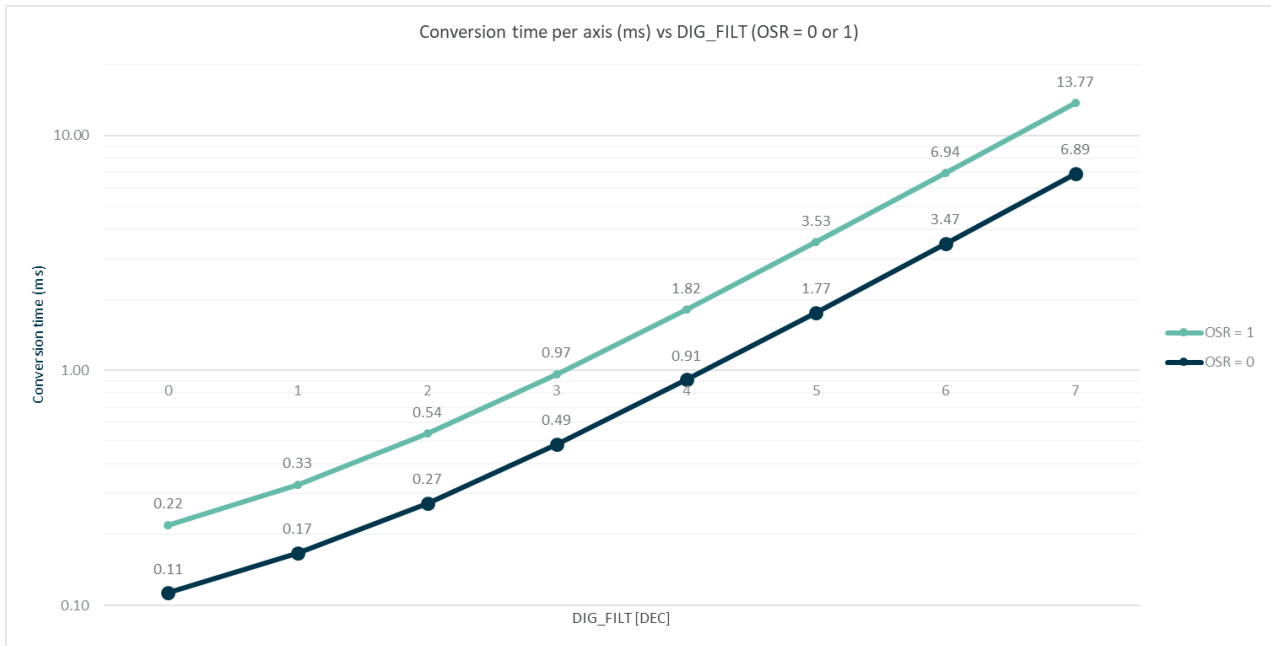

Figure 9: Conversion time

The above graph can be expressed with the following formula:

$$T_{\text{conv}}(\text{DIG\_FILT}) = \frac{16 + 2^{(\text{OSR}+5)} \cdot [2^{(\text{DIG\_FILT}+2)} + 4]}{F_{\text{clk}}}$$

$$F_{\text{clk}} = 2.4\text{MHz (typ)}$$

## 5. Functional Description

### 5.1. Device Configuration for Magnetic measurements

MLX90394 has three configurations for magnetic measurements selectable by the user:

- Low Current High Range (CONFIG = 0)
- Low Noise High Range (CONFIG = 1)
- Low Noise High Sensitivity (CONFIG = 2)

The current consumption specification can be found in Section 4.3. The noise specification can be found in Section 4.4. The magnetic range specification can be found in Section 5.3.5.

### 5.2. Configuration of SDA and INTB pin function

SDA and INTB pins can both be used interchangeably as I<sup>2</sup>C bus data input/output. Which pin will be used for data communication is automatically configured upon start of communication. It is required that the pin not used for communication is held HIGH and tied to VDD always through a pull-up resistor. It is recommended to connect a pull-up resistance to VDD in order to avoid accidental short circuit current due to pin misuse – accidental wrong configuration by the user.

Pin #	Pin Name	Connected to	I <sup>2</sup> C Slave Address	Function
1	SDA	SDA bus line	0x10h	I <sup>2</sup> C Bus Data Input/Output
6	INTB	Tied to VDD through a pull-up resistor	0x10h	WOC Interrupt Output, Synchronization Output or not used

Table 14 MLX90394RLD-AAA-000-RE interface with SDA pin connected to the SDA bus line

Pin #	Pin Name	Connected to	I <sup>2</sup> C Slave Address	Function
1	SDA	Tied to VDD through a pull-up resistor	0x11h	WOC Interrupt Output, Synchronization Output or not used
6	INTB	SDA bus line	0x11h	I <sup>2</sup> C Bus Data Input/Output

Table 15 MLX90394RLD-AAA-000-RE interface with INTB pin connected to the SDA bus line

Pin #	Pin Name	Connected to	I <sup>2</sup> C Slave Address	Function
1	SDA	SDA bus line	0x60h	I <sup>2</sup> C Bus Data Input/Output
6	INTB	Tied to VDD through a pull-up resistor	0x60h	WOC Interrupt Output, Synchronization Output or not used

Table 16 MLX90394RLD-AAA-001-RE interface with SDA pin connected to the SDA bus line

Pin #	Pin Name	Connected to	I <sup>2</sup> C Slave Address	Function
1	SDA	Tied to VDD through a pull-up resistor	0x61h	WOC Interrupt Output, Synchronization Output or not used
6	INTB	SDA bus line	0x61h	I <sup>2</sup> C Bus Data Input/Output

Table 17 MLX90394RLD-AAA-001-RE interface with INTB pin connected to the SDA bus line

Pin #	Pin Name	Connected to	I <sup>2</sup> C Slave Address	Function
1	SDA	SDA bus line	0x68h	I <sup>2</sup> C Bus Data Input/Output
6	INTB	Tied to VDD through a pull-up resistor	0x68h	WOC Interrupt Output, Synchronization Output or not used

Table 18 MLX90394RLD-AAA-002-RE interface with SDA pin connected to the SDA bus line

Pin #	Pin Name	Connected to	I <sup>2</sup> C Slave Address	Function
1	SDA	Tied to VDD through a pull-up resistor	0x69h	WOC Interrupt Output, Synchronization Output or not used
6	INTB	SDA bus line	0x69h	I <sup>2</sup> C Bus Data Input/Output

Table 19 MLX90394RLD-AAA-002-RE interface with INTB pin connected to the SDA bus line

Pin #	Pin Name	Connected to	I <sup>2</sup> C Slave Address	Function
1	SDA	SDA bus line	0x6Ah	I <sup>2</sup> C Bus Data Input/Output
6	INTB	Tied to VDD through a pull-up resistor	0x6Ah	WOC Interrupt Output, Synchronization Output or not used

Table 20 MLX90394RLD-AAA-003-RE interface with SDA pin connected to the SDA bus line

Pin #	Pin Name	Connected to	I <sup>2</sup> C Slave Address	Function
1	SDA	Tied to VDD through a pull-up resistor	0x6Bh	WOC Interrupt Output, Synchronization Output or not used
6	INTB	SDA bus line	0x6Bh	I <sup>2</sup> C Bus Data Input/Output

Table 21 MLX90394RLD-AAA-003-RE interface with INTB pin connected to the SDA bus line

MLX90394 has a predefined default I<sup>2</sup>C address 0x10h (MLX90394RLD-AAA-000-RE). This address can be changed to 0x11h if SDA and INTB pins are swapped. This enables the coexistence of two identical MLX90394 devices on the same I<sup>2</sup>C bus. Similarly, MLX90394RLD-AAA-001-RE features I<sup>2</sup>C slave addresses 0x60 and 0x61, MLX90394RLD-AAA-002-RE features I<sup>2</sup>C slave addresses 0x68 and 0x69 and MLX90394RLD-AAA-003-RE features I<sup>2</sup>C slave addresses 0x6A and 0x6B.

### 5.3. Operating Modes

MLX90394 has the following Application modes

1. Power Down mode (Deep Sleep)
2. Single measurement mode
3. Continuous measurement mode (5Hz, 10Hz, 15Hz, 50Hz, 100Hz, 200Hz, 500Hz, 700Hz, 1000Hz, 1400Hz)
4. Wake-up on change (5Hz, 10Hz, 15Hz, 50Hz, 100Hz, 200Hz, 500Hz, 700Hz, 1000Hz, 1400Hz)

Both Continuous and Wake-up on change modes measure periodically the magnetic field and (or) the temperature with a duty cycle defined by OSR\_HALL, OSR\_TEMP, DIG\_FILT\_HALL\_XY, DIG\_FILT\_HALL\_Z and DIG\_FILT\_TEMP.

#### 5.3.1. Single measurement mode

When the *Single measurement mode* is set, a magnetic measurement is started. After a measurement and when the signal processing is finished, the measurement data is stored to the data registers (**X**, **Y** and **Z**). After this, the sensor will go to the *Power Down mode* automatically.

While going to the *Power Down mode*, **MODE[3:0]** bits turns to 0. At the same time, **DRDY** bit (Data Ready) in **STAT1** register turns to High.

When any of measurement data register (**X**, **Y** and **Z**) is read, **DRDY** bit turns to Low. It remains High when switching from *Power Down mode* to another mode.

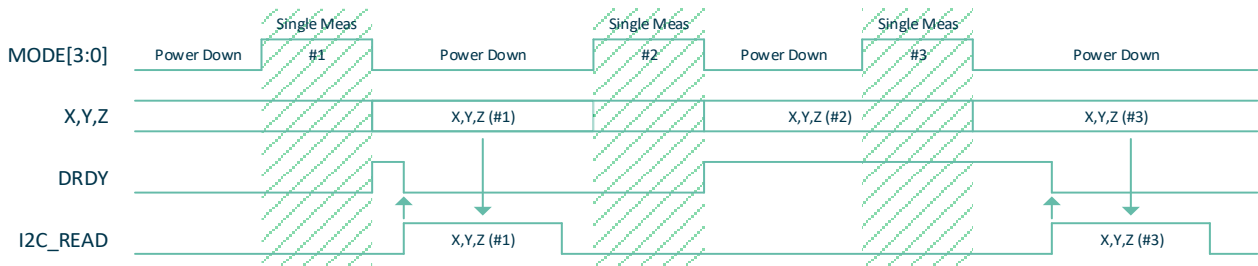

Figure 10: Single measurement mode when data is read out of measurement period

When the sensor is measuring, the data registers (**X**, **Y** and **Z**) keep the previous data. Therefore, it is possible to read out data even during measurement periods.

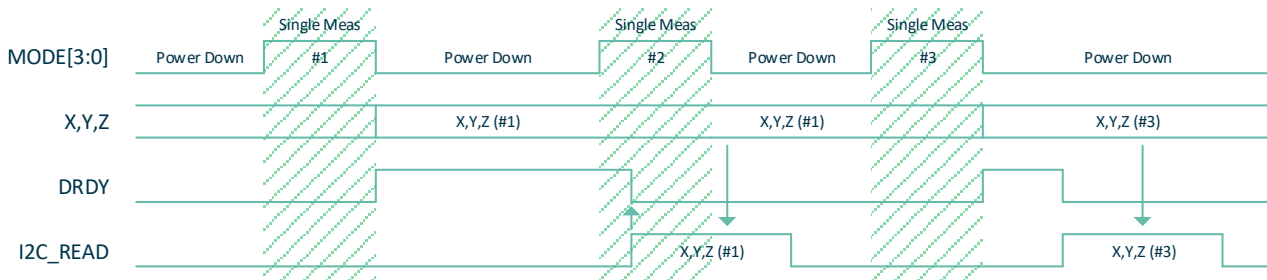

Figure 11: Single measurement mode when data read started during measurement period

### 5.3.2. Continuous measurement Mode

When the "Continuous measurement" mode is set, the measurement starts periodically. After measurement and signal processing is finished, the measurement data is stored to the data registers (X, Y, and Z). Almost all internal blocks are disabled ("Counting" power state).

After a measurement period, the device wakes up automatically from "Counting" power state and starts a new measurement.

The Continuous measurement mode ends when "Power Down" mode (MODE[3:0] bits = 0) is set. If the measurement period is changed while the device is already configured in "Continuous measurement" mode, a new measurement starts.

STAT1 and measurement data registers (X, Y and Z) will not be initialized by this.

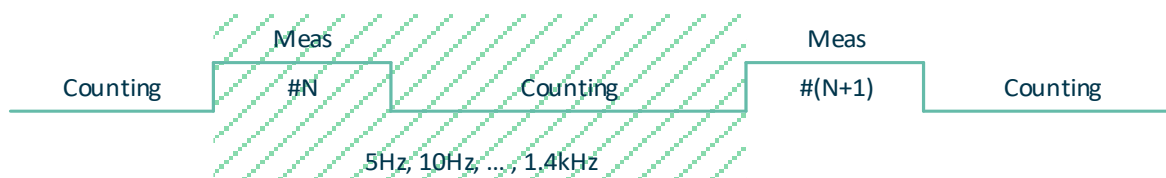

Figure 12: Continuous measurement mode

#### 5.3.2.1. Data Ready

When the measurement data is stored and ready to be read, the **DRDY** bit (Data Ready) in STAT1 register is set to High. When a measurement is performed correctly, the device sets the Data Ready bit before going back to "Counting" or "Wake-up on Change" power state.

#### 5.3.2.2. Normal Read Sequence

The stored measurement data is protected during the data reading. There is no update of the data during this time. Consequently, the following sequence should be followed:

1. **Check if the Data is Ready or not** by polling **DRDY** bit of **STAT1** register
  - a. **DRDY**: Data Ready. The Data is ready when set High.
2. Reading of the STAT1 register will not trigger the protection.
3. **Read measurement data** - When **any** of the measurement data register (X, Y, or Z) is read, the device enables the protection as soon as the register is copied into the I<sup>2</sup>C sending register. When data reading starts, **DRDY** (Data Ready) bit turns Low.
4. **Read STAT2 register (required for data consistency - provides information on overflow and data skip)**

When this read sequence is followed and there is no attempted I<sup>2</sup>C read during measurement, reading of STAT2 sets the DOR (Data Overrun) bit to low (see I/O registers description for reference).

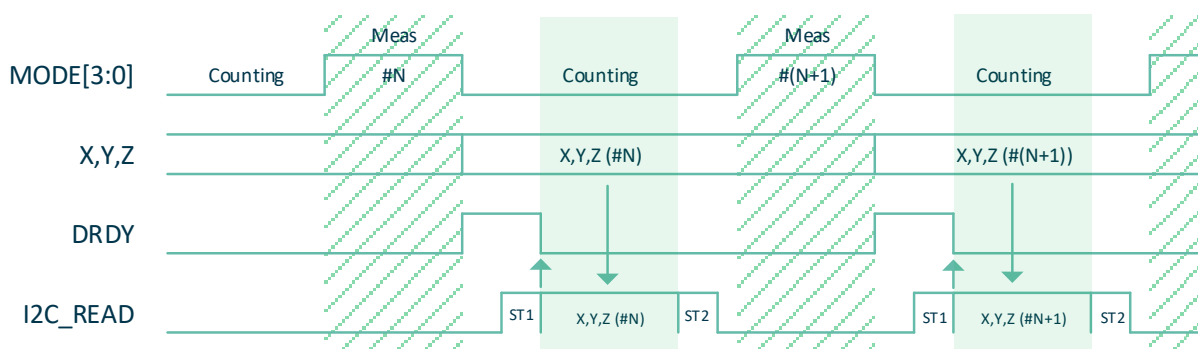

Figure 13: Normal read sequence

5.3.2.3. **Data Read Start during Measurement**

When the sensor is measuring, the measurement data registers (X, Y and Z) keep the previous data. Therefore, it is possible to read out data even in measurement period.

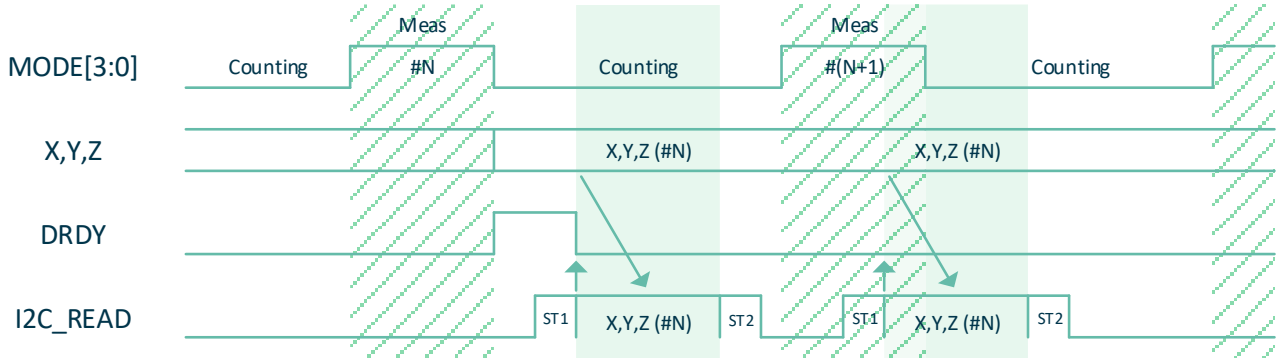

Figure 14: Data read start during measurement

5.3.2.4. **Data Skip**

If the available data is not read before a new measurement ends, the DRDY bit (Data Ready) remains High. However, a new set of measurement data will replace the previous one.

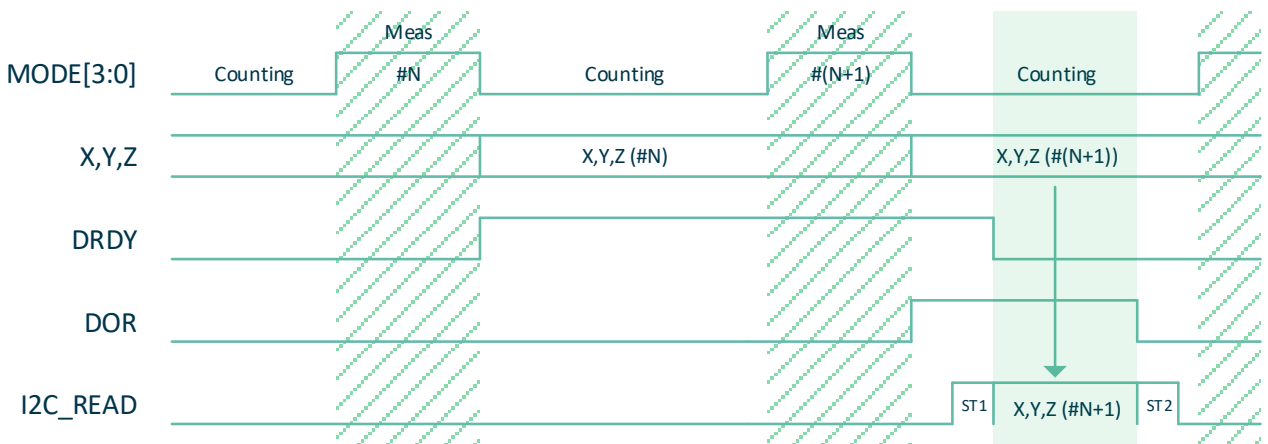

Figure 15: Data Skip: When data is not read

If the available data is read while a new measurement is being performed, this set of data will be protected. This is also the case even if the reading procedure finishes after the measurement. Consequently, this new set of data is skipped.

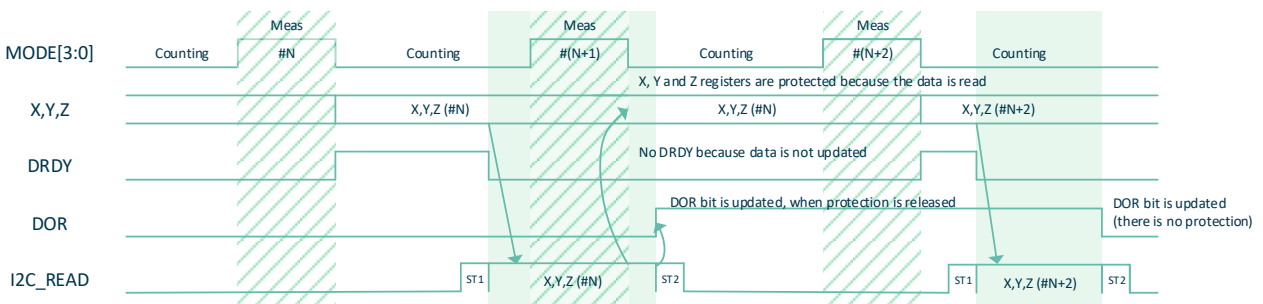

Figure 16: Data Skip: When data read has not been finished before the next measurement end

### 5.3.2.5. End Operation

Set the Power Down mode (**MODE[3:0] bits = 0**) to end the Continuous measurement mode.

### 5.3.3. Wake-up On Change Mode

This mode of operation can be enabled when setting the **SWOC** bit. As in Continuous measurement mode, the device wakes up periodically and measures the enabled axes and the temperature if enabled. When the current reading, the difference or the differential of the reading of any of the enabled axes exceeds a predefined threshold defined by the user, MLX90394 issues an interrupt. The interrupt can be configured to be signaled in two ways through INTB\_SCL\_B bit:

1. Pulling the SCL line low for 16  $\mu$ s. The duration of the pulse is configurable  $\rightarrow$  8 $\mu$ s, 16 $\mu$ s, 32 $\mu$ s, 64 $\mu$ s by changing the INTDUR[1:0] bits
2. Latching low of INTB or SDA pin, depending on the connection to the I<sup>2</sup>C bus

The condition for interrupt can be Static Delta, Dynamic Delta or Absolute Thresholds:

1. **Static Delta**  $\rightarrow$  the measured field is greater in magnitude **with a predefined threshold than the first read value** after WOC enter. The threshold is interpreted as an unsigned 15-bit value. Set X(Y/Z)\_THR[15]=0<sup>20</sup>.
2. **Dynamic Delta**  $\rightarrow$  the measured field is greater in magnitude **with a predefined threshold than the previous read value**. The threshold is interpreted as an unsigned 15-bit value. Set X(Y/Z)\_THR[15]=0<sup>20</sup>.
3. **Absolute Thresholds**  $\rightarrow$  the measured field is greater **than a predefined threshold**. The threshold is interpreted as a signed 2's complement 16-bit value.

Which condition is used in the application is controlled by WOC\_MODE[1:0] in the user address space.

When an interrupt condition occurs, the INT flag is set in the STAT1 register. It is cleared upon reading STAT1 register. The figures below describe the behavior of the interrupt.

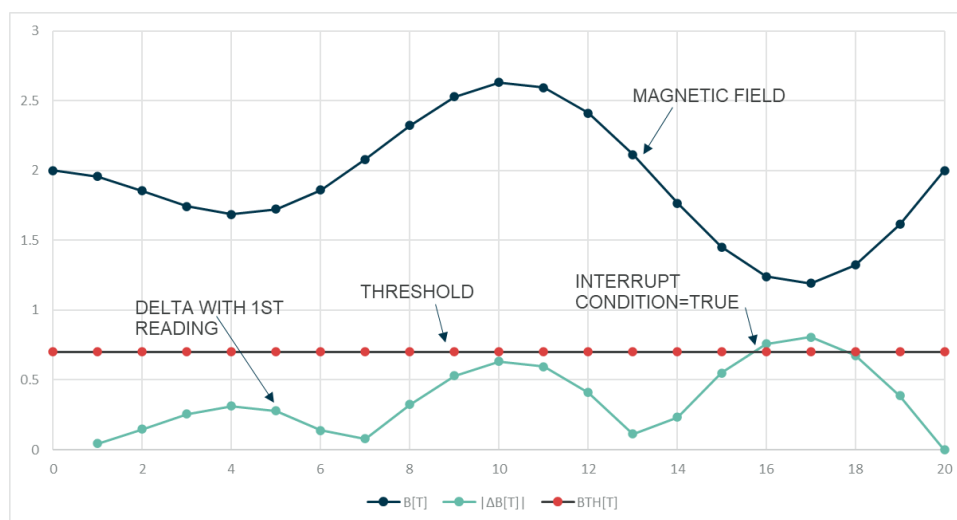

Figure 17 Conceptual representation of Static Delta WOC behavior

<sup>20</sup> In case Set X(Y/Z)\_THR[15]=1, MLX90394 will not issue an interrupt, irrespective of the threshold value

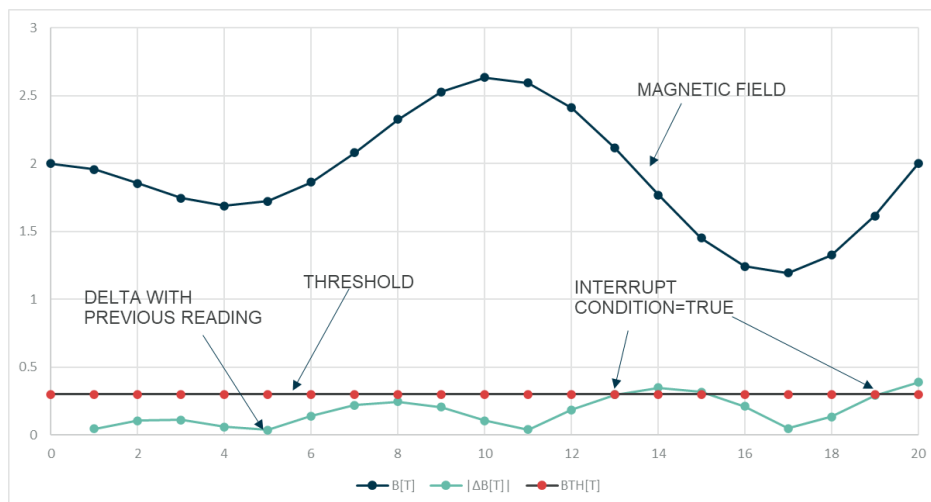

Figure 18 Conceptual representation of Dynamic Delta WOC behavior

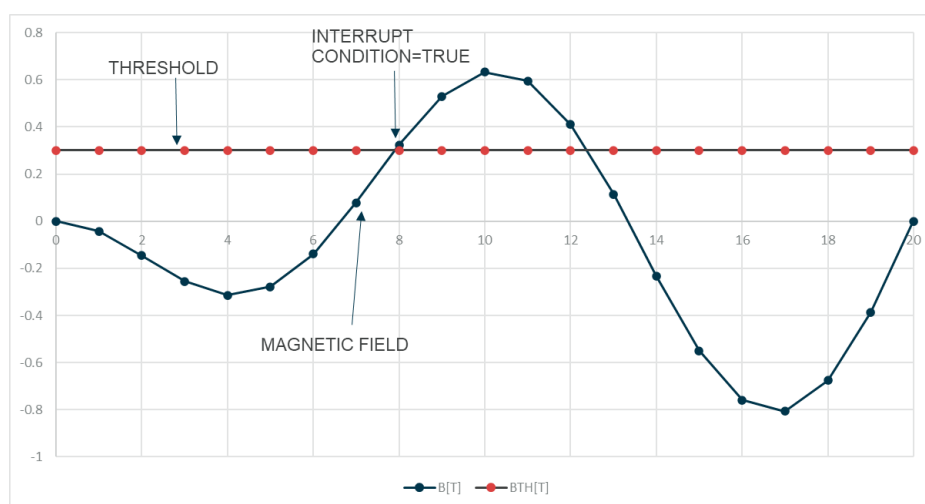

Figure 19 Conceptual representation of Absolute positive WOC behavior

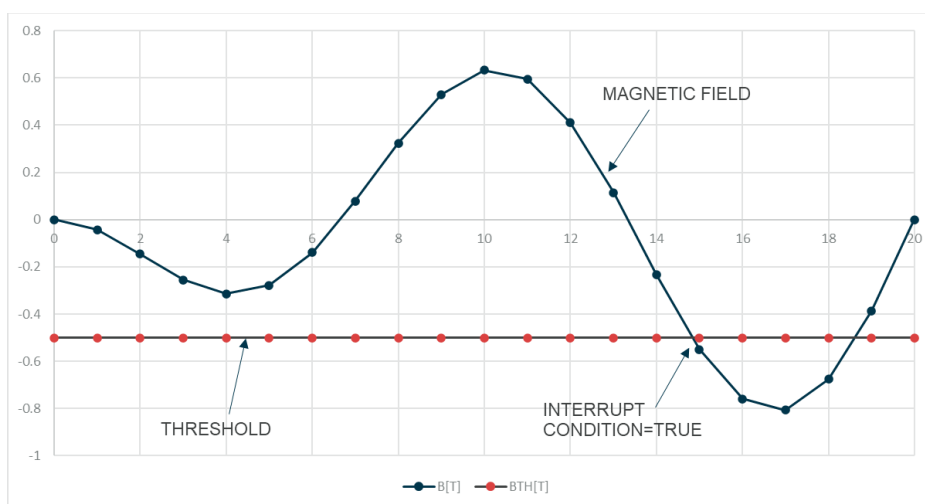

Figure 20 Conceptual representation of Absolute negative WOC behavior

The wake-up on change (WOC) interrupt can be configured (INTREPB=0 (default)) so that it keeps repeating until WOC mode is exit, regardless of whether STAT1 was read or not, once an interrupt condition is detected. Reading STAT1 will clear the interrupt until the next measurement only.

If INTREPB=1, then the interrupt will stop repeating when STAT1 register is read even though WOC mode was not exit.

Condition X: if  $X\_EN = 1'b1$ ,  $|X(\#N+n) - X(\#N)| > X(THR) \rightarrow TRUE/FALSE$   
 or  
 Condition Y: If  $Y\_EN = 1'b1$ ,  $|Y(\#N+n) - Y(\#N)| > Y(THR) \rightarrow TRUE/FALSE$   
 or  
 Condition Z: If  $Z\_EN = 1'b1$ ,  $|Z(\#N+n) - Z(\#N)| > Z(THR) \rightarrow TRUE/FALSE$

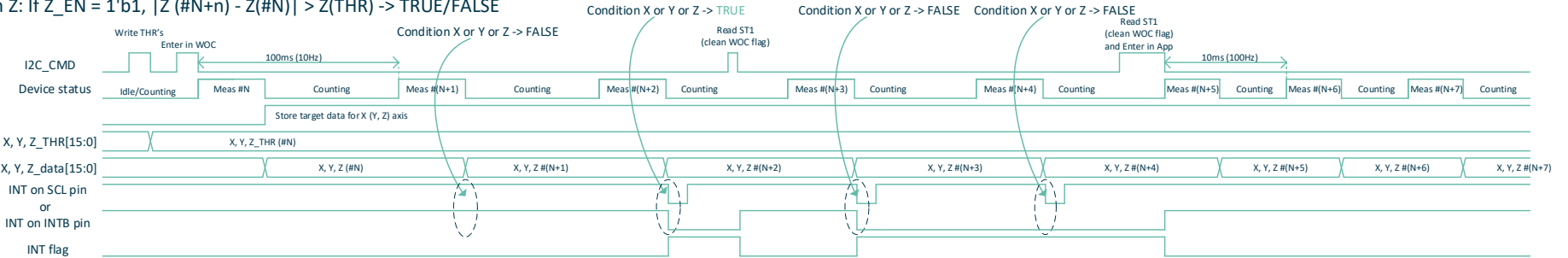

Figure 21 Static Delta WOC example with 1<sup>st</sup> measurement after WOC enter. Repetitive interrupt

Condition X: if  $X\_EN = 1'b1$ ,  $|X(\#N+n) - X(\#N+n-1)| > X(THR) \rightarrow TRUE/FALSE$   
 or  
 Condition Y: If  $Y\_EN = 1'b1$ ,  $|Y(\#N+n) - Y(\#N+n-1)| > Y(THR) \rightarrow TRUE/FALSE$   
 or  
 Condition Z: If  $Z\_EN = 1'b1$ ,  $|Z(\#N+n) - Z(\#N+n-1)| > Z(THR) \rightarrow TRUE/FALSE$

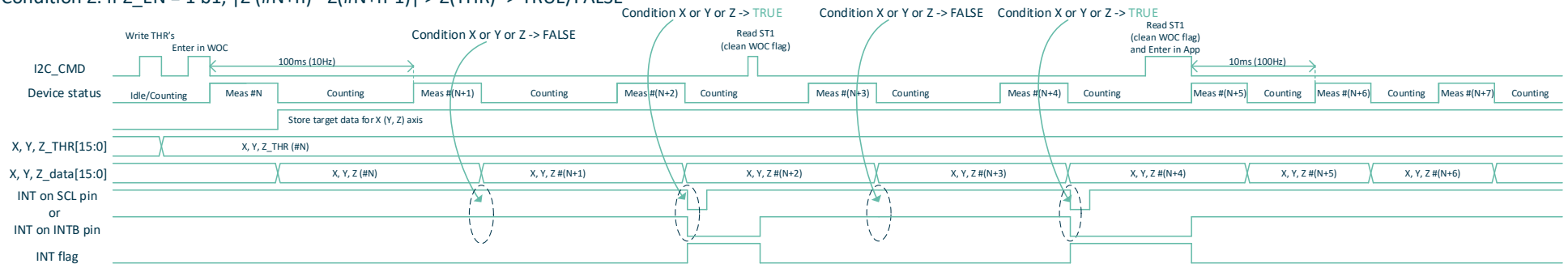

Figure 22 Dynamic Delta WOC example. Comparison of each measurement with the threshold after WOC enter, Single interrupt

### 5.3.4. Power Down (Deep Sleep)

In Power Down mode, the device is in minimal power consumption state. All internal blocks including the oscillator are disabled except the POR circuit. Only the communication over the I<sup>2</sup>C interface is maintained. The digital handling of the communication is clocked by the I<sup>2</sup>C master clock. All registers remain accessible and the data stored in read/write registers remains.

### 5.3.5. Magnetic Sensor Overflow

The device has a built in overflow detection

2's complement	Hex	Dec	Magnetic flux density [μT] CONFIG = 0,1	Magnetic flux density [μT] CONFIG = 2
0111_1111_1111_0000	7FF0	32752	49 128	4912.8
0000_0000_0000_0001	0001	1	1.5	0.15
0000_0000_0000_0000	0000	0	0	0
1111_1111_1111_1111	FFFF	-1	-1.5	-0.15
1000_0000_0001_0000	8010	-32752	-49 128	-4912.8

Table 22 - Measurement magnetic data format

When the magnetic field exceeds the limitation, data stored at measurement data are not correct. This is called Magnetic Sensor Overflow.

For X axis overflow flag condition is:  $|X| > 32,752$   
When the condition is fulfilled, HOFL\_X bit turns to "1".

For Y axis overflow flag condition is:  $|Y| > 32,752$   
When the condition is fulfilled, HOFL\_Y bit turns to "1".

For Z axis overflow check is:  $|Z| > 32,752$  If the condition is fulfilled, the HOFL\_Z bit turns to "1".  
When measurement data register (X, Y and Z) is updated, HOFL\_X, HOFL\_Y and HOFL\_Z bits are updated, too.

## 5.4. Output protocol (I<sup>2</sup>C) description

### 5.4.1. Command implementation

The following I<sup>2</sup>C commands are implemented:

- **MEM\_DIRECT\_READ:** reads data from memory space, starting from the default address 0x00
- **MEM\_READ:** the start address will be specified in the command and the address will be incremented for continuous reading until an I<sup>2</sup>C stop is detected.
- **MEM\_WRITE:** the start address will be specified followed by the data to be stored at addresses starting from the given start address and incremented until an I<sup>2</sup>C stop is detected.
- **ADDRESSED\_RESET:** reset of the device, based on the I<sup>2</sup>C Slave Address (reset of addressed devices on the I<sup>2</sup>C bus only)

In the next sections, the format of the different I<sup>2</sup>C commands is explained.  
The following legend is used:

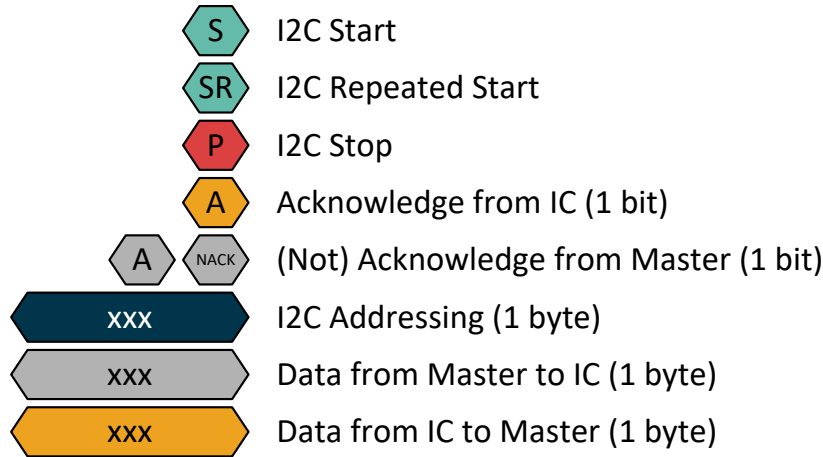

5.4.1.1. **Read Commands**

There are two read commands that are implemented

- **MEM\_DIRECT\_READ:** reads data from memory space, starting from the default address 0x00
- **MEM\_READ:** the start address will be specified in the command and the address will be incremented for continuous reading until an I<sup>2</sup>C stop is detected.

5.4.1.1.1. MEM\_DIRECT\_READ (direct read) Command

**MEM\_DIRECT\_READ:** reads data from memory space, starting from the default address 0x00



Figure 23: I<sup>2</sup>C - MEM\_DIRECT\_READ (direct read) Command

NOTES:

- Incremental readout – return 0x00 when address out of valid space
- **NAK is needed from master** to allow going to STOP

5.4.1.1.2. MEM\_READ (addressed read)

**MEM\_READ:** the start address will be specified in the command and the address will be incremented for continuous reading until an I<sup>2</sup>C stop (P) is detected.

Incremental read-out starting at a given address (Register Start Address).

Continuous transmission of data in sequential register addresses until the communication is terminated by the master.



Figure 11: I<sup>2</sup>C - MEM\_READ (addressed read)

**Important! A repeated START is required to perform an “addressed read”. Without repeated START, the command will be seen as a “direct read”.**

As soon as incremental addressing leaves the address space, the slave will respond with all 0x00.

NOTES:

- Incremental readout – return 0x00 when address out of valid space
- **NAK is needed from master** to allow going to STOP

5.4.1.2. **MEM\_WRITE (addressed write) Command**

**MEM\_WRITE:** the start address will be specified followed by the data to be stored at addresses starting from the given start address and incremented until an I<sup>2</sup>C stop (P) is detected.

Incremental write starting at a given address (Register Start Address).

Normally only 1x register is written, but optionally the master can continue to transmit data of sequential register addresses to reduce the communication time when a lot of registers should be written.

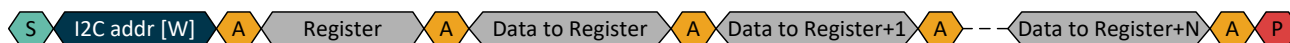

Figure 24: I<sup>2</sup>C - MEM\_WRITE (addressed write) Command

The slave is sending AK/NAK based on the fact whether it was able to write data

The slave will automatically increment the address of the read out byte, independent if it gave an AK or a NAK to the master. It is up to the master to re-write the byte afterwards.

When the device is busy with the write operation, new write commands will be ignored. A read operation will return invalid data.

### 5.4.1.3. ADDRESSED\_RESET: Addressed reset

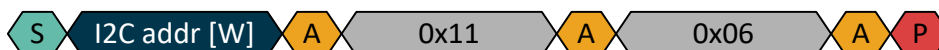

The addressed reset command brings the device back into a state like it was after power-on.

The I<sup>2</sup>C Slave Address is used, which means that only the addressed devices on the I<sup>2</sup>C bus will be reset.

## 5.5. Memory items description

### 5.5.1. Memory Structure

The MLX90394 has registers (ports) of 16 addresses. Each address consists of 8 bits data.

Data is transferred to or received from the external CPU via the I<sup>2</sup>C interface.

Address	Name	Description	R/W	7	6	5	4	3	2	1	0
0x00	STAT1	Status Register 1	R	-	-	-	INT	RT	-	-	DRDY
0x01	X[7:0]	X-axis Measurement Magnetic Data low byte	R	-	-	-	-	-	-	-	-
0x02	X[15:8]	X-axis Measurement Magnetic Data high byte	R	-	-	-	-	-	-	-	-
0x03	Y[7:0]	Y-axis Measurement Magnetic Data low byte	R	-	-	-	-	-	-	-	-
0x04	Y[15:8]	Y-axis Measurement Magnetic Data high byte	R	-	-	-	-	-	-	-	-
0x05	Z[7:0]	Z-axis Measurement Magnetic Data low byte	R	-	-	-	-	-	-	-	-
0x06	Z[15:8]	Z-axis Measurement Magnetic Data high byte	R	-	-	-	-	-	-	-	-
0x07	STAT2	Status Register 2	R	-	-	-	-	DOR	HOVF_Z	HOVF_Y	HOVF_X
0x08	T[7:0]	Temperature Measurement Data low byte	R	-	-	-	-	-	-	-	-
0x09	T[15:8]	Temperature Measurement Data high byte	R	-	-	-	-	-	-	-	-
0x0A	CID	Company ID [7:0]	R	-	-	-	-	-	-	-	-
0x0B	DID	Device ID [7:0]	R	-	-	-	-	-	-	-	-
0x0C		Reserved		-	-	-	-	-	-	-	-
0x0D		Reserved		-	-	-	-	-	-	-	-
0x0E	CTRL1	Control Register 1	R/W	SWOC	Z_EN	Y_EN	X_EN	MODE[3:0]			
0x0F	CTRL2	Control Register 2	R/W	CONFIG[1:0]		INTDUR[1:0]		INTB_SCL_B	INTREP_B	WOC_MODE[1:0]	
0x10		Reserved		-	-	-	-	-	-	-	-
0x11	RST	Reset = 0x06	R/W	-	-	-	-	-	-	-	-
0x12		Reserved		-	-	-	-	-	-	-	-
0x13		Reserved		-	-	-	-	-	-	-	-
0x14	CTRL3	Control Register 3	R/W	OSR_HALL	OSR_TEMP	DIG_FILT_HALL_XY[2:0]		DIG_FILT_TEMP[2:0]			
0x15	CTRL4	Control Register 4	R/W	DNC=1	DNC=0	T_EN	DNC=1	DRDY_EN	DIG_FILT_HALL_Z[2:0]		
.....											
0x58	X_THR[7:0]	X axis WOC threshold low byte	R/W				X_THR[7:0]				
0x59	X_THR[15:8]	X axis WOC threshold high byte	R/W				X_THR[15:8]				
0x5A	Y_THR[7:0]	Y axis WOC threshold low byte	R/W				Y_THR[7:0]				
0x5B	Y_THR[15:8]	Y axis WOC threshold high byte	R/W				Y_THR[15:8]				
0x5C	Z_THR[7:0]	Z axis WOC threshold low byte	R/W				Z_THR[7:0]				
0x5D	Z_THR[15:8]	Z axis WOC threshold high byte	R/W				Z_THR[15:8]				

Table 23 – Memory map

DNC = Do Not Change

The **STAT1** register is mapped on address **0x00**, since it is the default address of **MEM\_DIRECT\_READ** (direct read) command.

The idea is that first the user has to read the status bits **DRDY** to check if there is new data and if there is new data, to continue the command to read the registers **X**, **Y** and **Z**.

## 5.5.2. I/O registers description

### Address 0x00

7	6	5	4	3	2	1	0
STAT1_7	STAT1_6	STAT1_5	INT	RT	STAT1_2	STAT1_1	DRDY
RW-0	RW-0	RW-0	RW-0	RW-1	RW-0	RW-0	RW-0

NOTE: R=Read access; W=Write access; value following dash (-) = value after initialization

Bit 7 – 5 **STAT1[7:5]. Reserved (Not used)**

**Bit 4** **INT.** Interrupt bit turns to "1" when the interrupt condition is satisfied during WOC. It returns to "0" when the STAT1 register is read. It is reset to "0" upon power on reset and upon entering WOC mode

**0** – The Interrupt is not active

**1** – The Interrupt is active

**Bit 3** **RT.** The device is reset

**0** – The device was not reset

**1** – The device was reset and this is the first reading. Automatically set to 0 when the first reading of STAT1 register is done

Bit 2 – 1 **STAT1[2:1]. Reserved (Not used)**

**Bit 0** **DRDY.** Data Ready.

DRDY bit turns to "1" when data is ready in "Single measurement" mode (1, 9), "Continuous measurement" mode (2, 3, 4, 5, 6, 10, 11, 12, 13, 14) or "Self-test" mode (7).

It returns to "0" when any of the measurement data registers (X, Y or Z) is read

**0** – Normal

**1** – Data is ReaDY

### Addresses 0x01 – 0x06

Magnetic measurement data for X, Y and Z axes

### Address 0x07

7	6	5	4	3	2	1	0
STAT2_7	STAT2_6	STAT2_5	STAT2_4	DOR	HOVF_Z	HOVF_Y	HOVF_X
RW-0	RW-0	RW-0	RW-0	RW-0	RW-0	RW-0	RW-0

NOTE: R=Read access; W=Write access; value following dash (-) = value after initialization

Bit 7 – 4 **STAT2[7:4]. Reserved (Not used)**

**Bit 3** **DOR.** Data Overrun

DOR bit turns to "1" when data has been skipped in "Continuous measurement" mode (2, 3, 4, 5, 6, 10, 11, 12, 13, 14).

It returns to "0" when any of the measurement data registers (X, Y or Z) is read.

**0** – Normal

**1** – Data OverRun

**Bit 2** **HOVF\_Z.** Magnetic Sensor OverFlow for Z axis measurement

**0** – Normal

**1** – Magnetic Sensor OverFlow for Z axis occurred

**Bit 1** **HOVF\_Y.** Magnetic Sensor OverFlow for Y axis measurement

**0** – Normal

**1** – Magnetic Sensor OverFlow for Y axis occurred

**Bit 0** **HOVF\_X.** Magnetic Sensor OverFlow for X axis measurements

**0** – Normal

**1** – Magnetic Sensor OverFlow for X axis occurred

### Addresses 0x08 – 0x09

Temperature measurement data

## Addresses 0x0A

Company ID = 0x94

## Addresses 0x0B

Device ID = 0xAA

### Address 0x0E – CTRL1 Register

7	6	5	4	3	2	1	0
SWOC	Z_EN	Y_EN	X_EN	MODE3	MDOE2	MODE1	MODE0
RW-0	RW-1	RW-1	RW-1	RW-0	RW-0	RW-0	RW-0

**NOTE:** R=Read access; W=Write access; value following dash (-) = value after initialization

- Bit 7**            **SWOC.** Start Wake-up On Change mode
- 0 – Disable
  - 1 – Enable
- Bit 6**            **Z\_EN.** Control magnetic measurement at Z axis
- 0 – Disable
  - 1 – Enable
- Bit 5**            **Y\_EN.** Control magnetic measurement at Y axis
- 0 – Disable
  - 1 – Enable
- Bit 4**            **X\_EN.** Control magnetic measurement at X axis
- 0 – Disable
  - 1 – Enable
- Bit 3 – 0**        **MODE[3:0].** Application Mode
- 0 – Power-down mode
  - 1 – Single Measurements mode
  - 2 – Continuous measurement mode 5Hz
  - 3 – Continuous measurement mode 10Hz
  - 4 – Continuous measurement mode 15Hz
  - 5 – Continuous measurement mode 50Hz
  - 6 – Continuous measurement mode 100Hz
  - 7 – Self-test mode
  - 8 – Power-down mode
  - 9 – Single Measurements mode
  - 10 – Continuous measurement mode 200Hz
  - 11 – Continuous measurement mode 500Hz
  - 12 – Continuous measurement mode 700Hz
  - 13 – Continuous measurement mode 1.0kHz
  - 14 – Continuous measurement mode 1.4kHz
  - 15 – Power-down mode

**NOTE:** The user needs to take care for correct configuration of OSR and DIG\_FILT according to the datasheet when selecting a certain refresh rate

### Address 0x0F – CTRL2 Register

7	6	5	4	3	2	1	0
CONFIG1	CONFIG0	INTDUR1	INTDURO	INTB_SCL_B	INTREP_B	WOC_MODE1	WOC_MODE0
RW-0	RW-0	RW-0	RW-0	RW-1	RW-0	RW-0	RW-0

NOTE: R=Read access; W=Write access; value following dash (-) = value after initialization

- Bit 7 - 6**      **CONFIG[1:0].** Range Configuration
- 0 – Configuration 0
  - 1 – Configuration 1
  - 2 – Configuration 2
  - 3 – Configuration 0
- Bit 5 - 4**      **INTDUR[1:0].** Configuration of interrupt pulse duration on SCL pin
- 0 – 4 x OSC\_SLOW clocks = 16us
  - 1 – 8 x OSC\_SLOW clocks = 32us
  - 2 – 1 x OSC\_SLOW clocks = 4us
  - 3 – 2 x OSC\_SLOW clocks = 8us
- Bit 3**          **INTB\_SCL\_B.** Select interrupt function on SCL pin or INTB pin
- 0 – Interrupt on SCL pin
  - 1 – Interrupt on INTB pin
- Bit 2**          **INTREP\_B.** Interrupt repetition configuration
- 0 – interrupt repeat after first time when condition is TRUE till WOC exit
  - 1 – interrupt repeat only if condition is TRUE
- Bit 1 - 0**      **WOC\_MODE[1:0].** WOC mode configurations
- 0 – Difference than 1st measurement in WOC
  - 1 – Difference than previous measurement in WOC
  - 2 – Absolute mode
  - 3 – Not used

### Address 0x11 – RESET Register

Writing 0x06 in this register resets the IC

### Address 0x14 – CTRL3 Register

7	6	5	4	3	2	1	0
OSR_HALL	OSR_TEMP	DIG_FILT_HALL_XY2	DIG_FILT_HALL_XY1	DIG_FILT_HALL_XY0	DIG_FILT_TEMP2	DIG_FILT_TEMP1	DIG_FILT_TEMP0
RW-1	RW-1	RW-1	RW-0	RW-0	RW-0	RW-0	RW-1

NOTE: R=Read access; W=Write access; value following dash (-) = value after initialization

- Bit 7**          **OSR\_HALL.** OSR setting for Hall Measurement
- Bit 6**          **OSR\_TEMP.** OSR setting for Temperature Measurement
- Bit 5 – 3**      **DIG\_FILT\_HALL\_XY[2:0].** Digital filter setting for X and Y Hall Measurements
- Bit 2 – 0**      **DIG\_FILT\_TEMP[2:0].** Digital filter setting for Temperature Measurement

### Address 0x15 – CTRL4 Register

7	6	5	4	3	2	1	0
CTRL4_7	CTRL4_6	T_EN	CTRL4_4	DRDY_EN	DIG_FILT_HALL_Z2	DIG_FILT_HALL_Z1	DIG_FILT_HALL_Z0
RW-1	RW-0	RW-0	RW-1	RW-0	RW-1	RW-0	RW-1

**NOTE:** R=Read access; W=Write access; value following dash (-) = value after initialization

- Bit 7**            **CTRL4\_7.** Reserved (keep set to 1 for proper operation)
- Bit 6**            **CTRL4\_6.** Reserved (keep set to 0 for proper operation)
- Bit 5**            **T\_EN.** Enable Temperature Measurement
- Bit 4**            **CTRL4\_4.** Reserved (keep set to 1 for proper operation)
- Bit 3**            **DRDY\_EN.** Enables DRDY flag on INTB or SDA pin (depending on the connection interface)
  - **0** – DRDY flag output disabled
  - **1** – DRDY flag output enabled. If used, **INTB\_SCL\_B** must be set
- Bit 2 – 0**        **DIG\_FILT\_HALL\_Z[2:0].** Digital filter setting for Z Hall Measurement

### Addresses 0x58 – 0x59

X axis WOC threshold low (0x58) and high (0x59) byte

### Addresses 0x5A – 0x5B

Y axis WOC threshold low (0x58) and high (0x59) byte

### Addresses 0x5C – 0x5D

Z axis WOC threshold low (0x58) and high (0x59) byte

These registers are initialized at 0 and are to be set by the user.

## 5.6. Flowchart

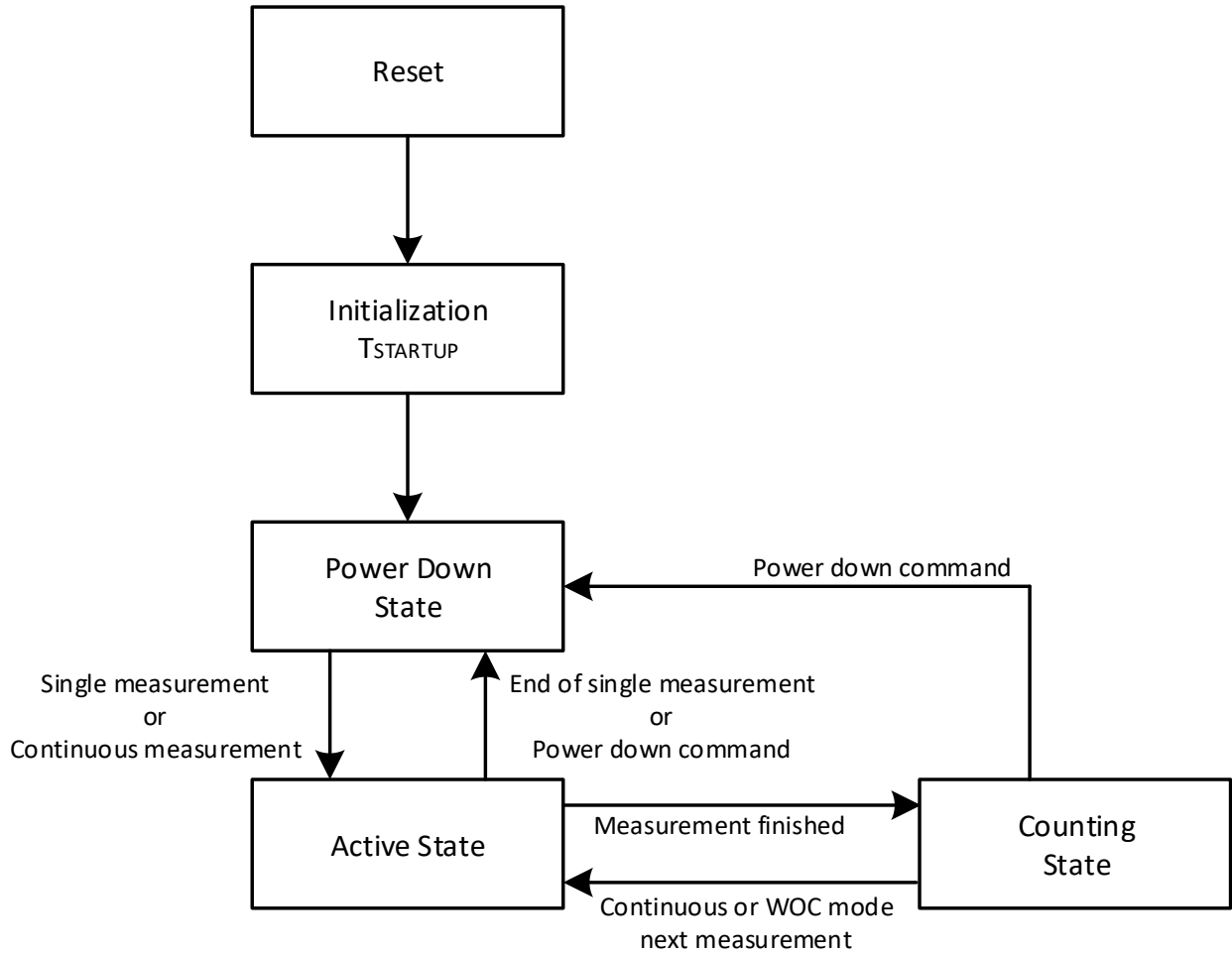

Figure 25: State Sequence flowchart

## 6. Application Information

### 6.1. Recommended Application Diagram

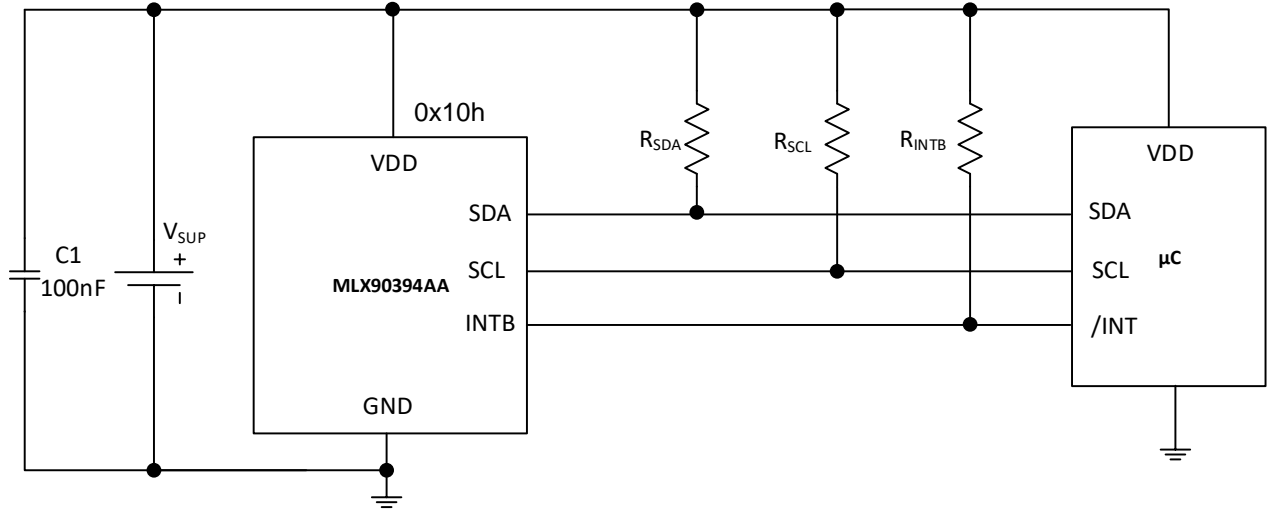

Figure 26: Recommended application diagram

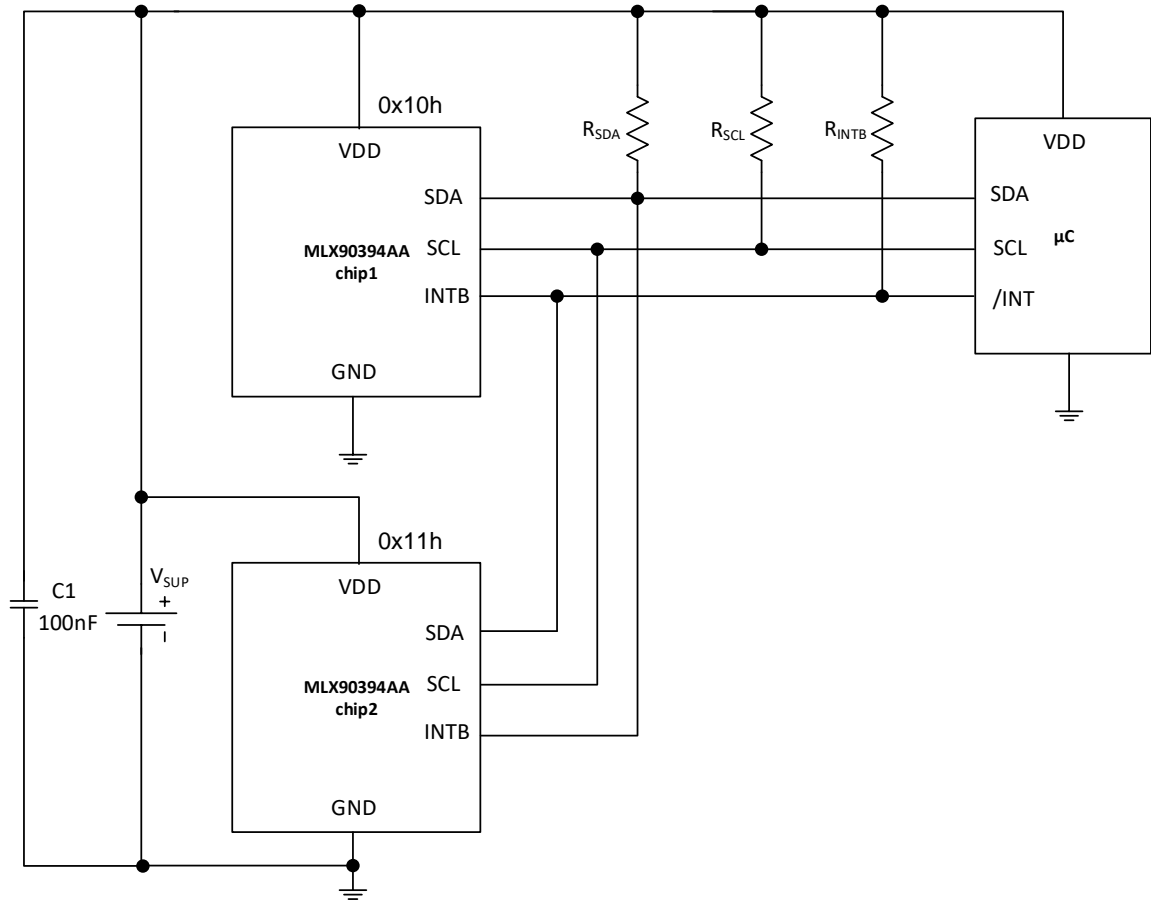

Figure 27 Application diagram with two MLX90394AA

## 7. Package, IC handling and assembly

### 7.1. Package information

#### 7.1.1. Dimensions

UTDFN6 1.5mm x 2mm

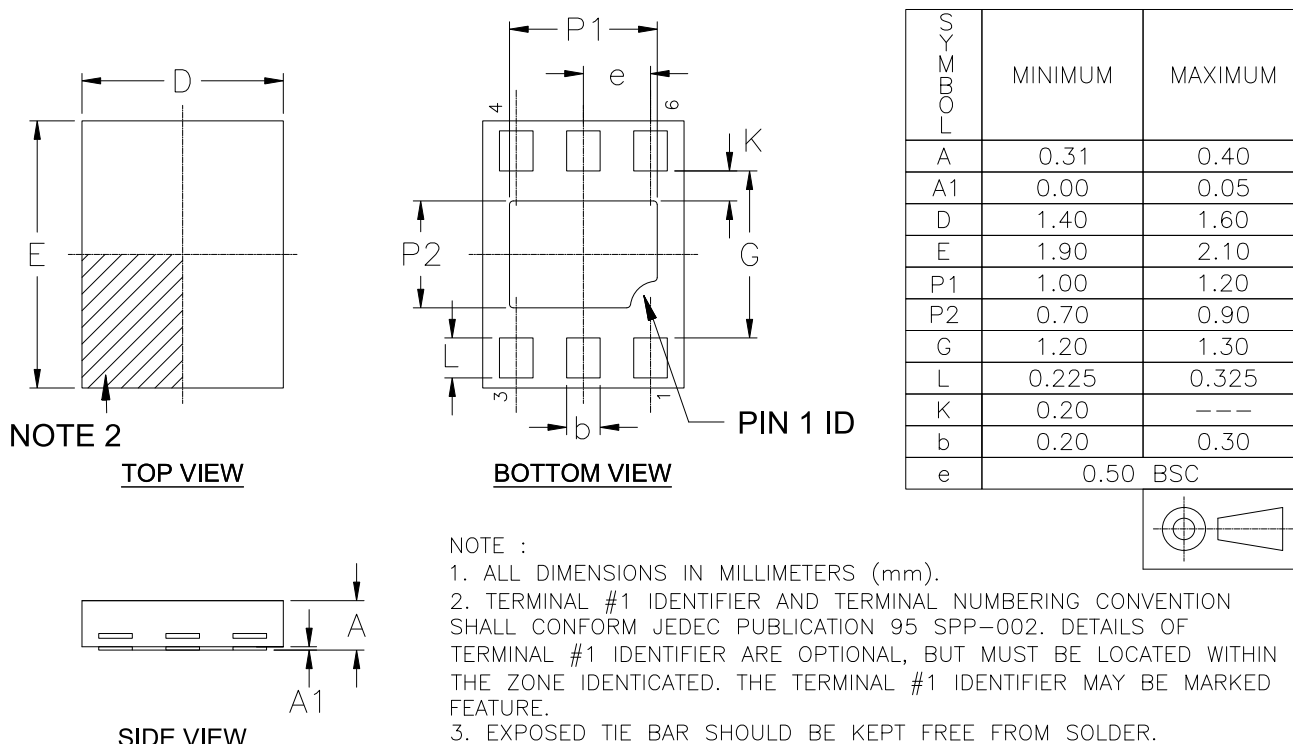
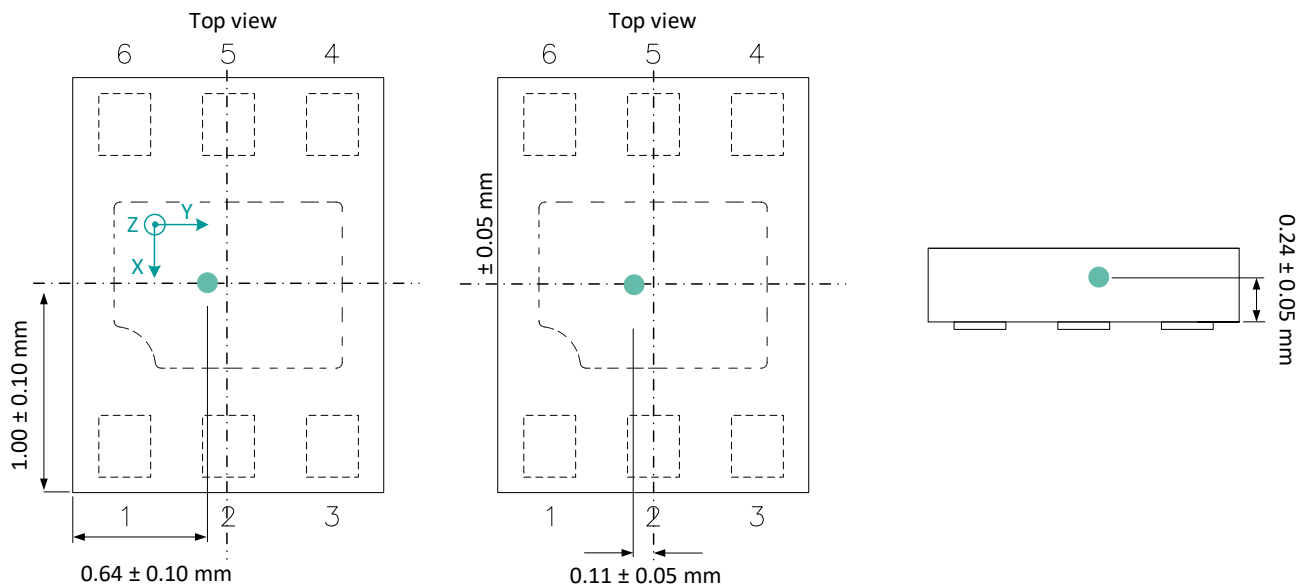
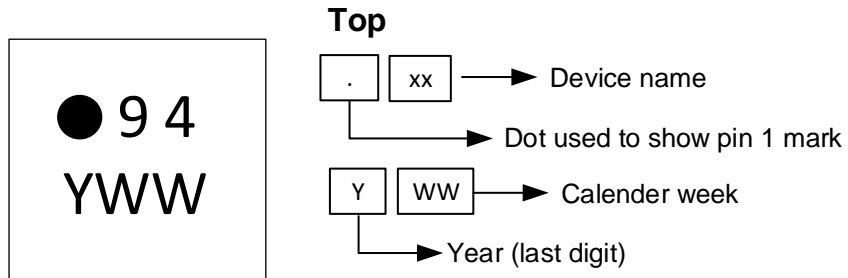

Figure 28 Preliminary Package Outline Drawing

#### 7.1.2. Sensing element location and field direction



### 7.1.3. UTDFN6 Package Marking



## 7.2. Storage and handling of plastic encapsulated ICs

Plastic encapsulated ICs shall be stored and handled according to their MSL categorization level (specified in the packing label) as per J-STD-033.

Electronic semiconductor products are sensitive to Electro Static Discharge (ESD). The component assembly shall be handled in EPA (Electrostatic Protected Area) as per ANSI S20.20

For more information refer to Melexis [\*Guidelines for storage and handling of plastic encapsulated ICs\*](#)<sup>21</sup>

## 7.3. Assembly of encapsulated ICs

For Surface Mounted Devices (SMD, as defined according to JEDEC norms), the only applicable soldering method is reflow.

For Through Hole Devices (THD), the applicable soldering methods are reflow, wave, selective wave and robot point-to-point. THD lead pre-forming (cutting and/or bending) is applicable under strict compliance with Melexis [\*Guidelines for lead forming of SIP Hall Sensors\*](#)<sup>21</sup>.

Melexis products soldering on PCB should be conducted according to the requirements of IPC/JEDEC and J-STD-001. Solder quality acceptance should follow the requirements of IPC-A-610.

For PCB-less assembly refer to the relevant application notes<sup>21</sup> or contact Melexis.

Electrical resistance welding or laser welding can be applied to Melexis products in THD and specific PCB-less packages following the [\*Guidelines for welding of PCB-less devices\*](#)<sup>21</sup>.

Environmental protection of customer assembly with Melexis products for harsh media application, is applicable by means of coating, potting or overmolding considering restrictions listed in the relevant application notes<sup>21</sup>

For other specific process, contact Melexis via [www.melexis.com/technical-inquiry](http://www.melexis.com/technical-inquiry)

## 7.4. Environment and sustainability

Melexis is contributing to global environmental conservation by promoting non-hazardous solutions.

For more information on our environmental policy and declarations (RoHS, REACH...) visit

[www.melexis.com/environmental-forms-and-declarations](http://www.melexis.com/environmental-forms-and-declarations)

---

<sup>21</sup> [www.melexis.com/ic-handling-and-assembly](http://www.melexis.com/ic-handling-and-assembly)

## 8. References

### 8.1. List of figures

Figure 1 UTRFN-6 .....	1
Figure 2: IC block diagram .....	5
Figure 3 XY axes noise as a function of DIG_FILT_HALL_XY. CONFIG=0.....	10
Figure 4 Z axis noise as a function of DIG_FILT_HALL_Z. CONFIG=0.....	10
Figure 5 XY axes noise as a function of DIG_FILT_HALL_XY. CONFIG=1.....	11
Figure 6 Z axis noise as a function of DIG_FILT_HALL_Z. CONFIG=1.....	11
Figure 7 XY axes noise as a function of DIG_FILT_HALL_XY. CONFIG=2.....	12
Figure 8 Z axis noise as a function of DIG_FILT_HALL_Z. CONFIG=2.....	12
Figure 9: Conversion time.....	14
Figure 10: Single measurement mode when data is read out of measurement period .....	17
Figure 11: Single measurement mode when data read started during measurement period .....	17
Figure 12: Continuous measurement mode.....	18
Figure 13: Normal read sequence .....	18
Figure 14: Data read start during measurement.....	19
Figure 15: Data Skip: When data is not read .....	19
Figure 16: Data Skip: When data read has not been finished before the next measurement end .....	19
Figure 17 Conceptual representation of Static Delta WOC behavior.....	20
Figure 18 Conceptual representation of Dynamic Delta WOC behavior.....	21
Figure 19 Conceptual representation of Absolute positive WOC behavior .....	21
Figure 20 Conceptual representation of Absolute negative WOC behavior .....	21
Figure 21 Static Delta WOC example with 1 <sup>st</sup> measurement after WOC enter. Repetitive interrupt.....	22
Figure 22 Dynamic Delta WOC example. Comparison of each measurement with the threshold after WOC enter, Single interrupt .....	22
Figure 23: I <sup>2</sup> C - MEM_DIRECT_READ (direct read) Command.....	24
Figure 24: I <sup>2</sup> C - MEM_WRITE (addressed write) Command .....	25
Figure 25: State Sequence flowchart.....	30
Figure 26: Recommended application diagram .....	31
Figure 27 Application diagram with two MLX90394AA .....	32
Figure 28 Preliminary Package Outline Drawing .....	33

## 8.2. List of tables

Table 1 – Ordering codes.....	3
Table 2 – Pin description .....	5
Table 3– Absolute Maximum Ratings.....	6
Table 4 – General operating conditions .....	6
Table 5 – Electrical Operating conditions.....	6
Table 6 – Thermal Characteristics .....	6
Table 7 – Magnetic Operating conditions .....	7
Table 8 Electrical specification .....	7
Table 9 Temperature sensor specification .....	8
Table 10 I <sup>2</sup> C DC Characteristics.....	8
Table 11 I <sup>2</sup> C bus and external connection requirements .....	8
Table 12 Magnetic Specifications .....	9
Table 13 – Timing specifications.....	13
Table 14 MLX90394RLD-AAA-000-RE interface with SDA pin connected to the SDA bus line.....	15
Table 15 MLX90394RLD-AAA-000-RE interface with INTB pin connected to the SDA bus line .....	15
Table 16 MLX90394RLD-AAA-001-RE interface with SDA pin connected to the SDA bus line.....	15
Table 17 MLX90394RLD-AAA-001-RE interface with INTB pin connected to the SDA bus line .....	15
Table 18 MLX90394RLD-AAA-002-RE interface with SDA pin connected to the SDA bus line.....	16
Table 19 MLX90394RLD-AAA-002-RE interface with INTB pin connected to the SDA bus line .....	16
Table 20 MLX90394RLD-AAA-003-RE interface with SDA pin connected to the SDA bus line.....	16
Table 21 MLX90394RLD-AAA-003-RE interface with INTB pin connected to the SDA bus line .....	16
Table 22 - Measurement magnetic data format .....	23
Table 23 – Memory map .....	25

## 9. Disclaimer

*The content of this document is believed to be correct and accurate. However, the content of this document is furnished "as is" for informational use only and no representation, nor warranty is provided by Melexis about its accuracy, nor about the results of its implementation. Melexis assumes no responsibility or liability for any errors or inaccuracies that may appear in this document. Customer will follow the practices contained in this document under its sole responsibility. This documentation is in fact provided without warranty, term, or condition of any kind, either implied or expressed, including but not limited to warranties of merchantability, satisfactory quality, non-infringement, and fitness for purpose. Melexis, its employees and agents and its affiliates' and their employees and agents will not be responsible for any loss, however arising, from the use of, or reliance on this document. Notwithstanding the foregoing, contractual obligations expressly undertaken in writing by Melexis prevail over this disclaimer.*

*This document is subject to change without notice, and should not be construed as a commitment by Melexis. Therefore, before placing orders or prior to designing the product into a system, users or any third party should obtain the latest version of the relevant information.*

*Users or any third party must determine the suitability of the product described in this document for its application, including the level of reliability required and determine whether it is fit for a particular purpose.*

*This document as well as the product here described may be subject to export control regulations. Be aware that export might require a prior authorization from competent authorities. The product is not designed, authorized or warranted to be suitable in applications requiring extended temperature range and/or unusual environmental requirements. High reliability applications, such as medical life-support or life-sustaining equipment or avionics application are specifically excluded by Melexis. The product may not be used for the following applications subject to export control regulations: the development, production, processing, operation, maintenance, storage, recognition or proliferation of:*

- 1. chemical, biological or nuclear weapons, or for the development, production, maintenance or storage of missiles for such weapons;*
- 2. civil firearms, including spare parts or ammunition for such arms;*
- 3. defense related products, or other material for military use or for law enforcement;*
- 4. any applications that, alone or in combination with other goods, substances or organisms could cause serious harm to persons or goods and that can be used as a means of violence in an armed conflict or any similar violent situation.*

*No license nor any other right or interest is granted to any of Melexis' or third party's intellectual property rights.*

*If this document is marked "restricted" or with similar words, or if in any case the content of this document is to be reasonably understood as being confidential, the recipient of this document shall not communicate, nor disclose to any third party, any part of the document without Melexis' express written consent. The recipient shall take all necessary measures to apply and preserve the confidential character of the document. In particular, the recipient shall (i) hold document in confidence with at least the same degree of care by which it maintains the confidentiality of its own proprietary and confidential information, but no less than reasonable care; (ii) restrict the disclosure of the document solely to its employees for the purpose for which this document was received, on a strictly need to know basis and providing that such persons to whom the document is disclosed are bound by confidentiality terms substantially similar to those in this disclaimer; (iii) use the document only in connection with the purpose for which this document was received, and reproduce document only to the extent necessary for such purposes; (iv) not use the document for commercial purposes or to the detriment of Melexis or its customers. The confidentiality obligations set forth in this disclaimer will have indefinite duration and in any case they will be effective for no less than 10 years from the receipt of this document.*

*This disclaimer will be governed by and construed in accordance with Belgian law and any disputes relating to this disclaimer will be subject to the exclusive jurisdiction of the courts of Brussels, Belgium.*

*The invalidity or ineffectiveness of any of the provisions of this disclaimer does not affect the validity or effectiveness of the other provisions.*

*The previous versions of this document are repealed.*

*Melexis © - No part of this document may be reproduced without the prior written consent of Melexis. (2026)*

*IATF 16949 and ISO 14001 Certified*