

1 General description

1.1 Features & benefits

- Arcminaxis® Technology combining Multi-axis sensing with Vernier Technology.
- Reduces the complexity and effort involved in assembling robotic joints
- Pitch-independent, one IC fits various magnets
- Large air gap sensor to magnet (1.5 mm nominal)
- Generous magnet-sensor placement tolerance of ± 0.5 mm
- 18 bits resolution
- Triaxis® Hall Technology
- Communication via fast SPI interface
- Output modes:
 - SPI/differential SSI
- TSSOP-16 Sensor Package RoHS compliant
- 3.3 V supply
- Temperature range -20°C to 85°C



Figure 1. *Sensor Chip in TSSOP-16 package*

1.2 Application examples

- Absolute Rotary Position Sensor
- High Resolution Encoder
 - Robotic Joint Encoder

1.3 Description

The MLX90384 is a four-component set, providing a flexible solution for your high-accuracy magnetic encoder needs.

a) All options include a sensor chip with two monolithic magnetic position sensor ICs, each consisting of a Triaxis® Hall magnetic front end, analog-to-digital converter, hardware for high-speed signal conditioning, and a 10 MHz high-speed SPI interface. The ICs are both configured to be sensitive to a first magnetic flux density component parallel with the chip plane and to a second component perpendicular to the chip.

b) A Vernier-type magnet with two tracks is included, enabling optimal system integration. The MLX90384 sensor chip measures the axial and tangential magnetic components of both tracks and transmits this information to a microcontroller which in turn generates the accurate angular position and speed as well as the counted turn out of this information.

c) A partially precompiled software library adjustable for any ARM microcontroller is provided to calibrate and operate the system.

d) Also included is a complete reference design to build your own encoder solution based on a), b) and c).



Figure 2. *The Arcminaxis® Vernier sensing concept combines two sensing spots with orthogonal components*

2 Ordering Information

To help ensure seamless, easy integration in your application, we offer different MLX90384 versions that include a compatible magnet for your MLX90384 encoder system.

The Software for the MLX90384 encoder system is provided by Melexis and must be programmed into the used microcontroller.

Order Code	Temperature range (°C)	Package	Packing	Definition
MLX90384SGO-BAA-001-TU MLX90384SGO-BAA-001-RE	-20 to 85	TSSOP-16	Tube Reel	MLX90384 Sensor chip with magnet 1
MLX90384SGO-BAA-002-TU MLX90384SGO-BAA-002-RE	-20 to 85	TSSOP-16	Tube Reel	MLX90384 Sensor chip with magnet 2
MLX90384SGO-BAA-003-TU MLX90384SGO-BAA-003-RE	-20 to 85	TSSOP-16	Tube Reel	MLX90384 Sensor chip with magnet 3
MLX90384SGO-BAA-004-TU MLX90384SGO-BAA-004-RE	-20 to 85	TSSOP-16	Tube Reel	MLX90384 Sensor chip with magnet 4

Table 1 - MLX90384 Order Codes

MLX90384SGO-BAA-001-RE

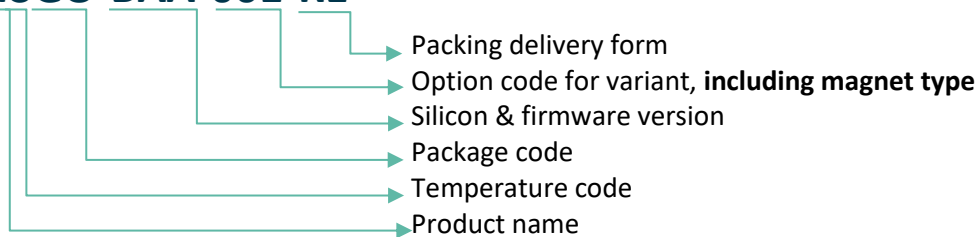

Temperature Code:	S: -20 °C to 85 °C
Package Code:	GO: TSSOP-16 package (Dual-Die side-by-side)
Silicon & firmware version:	BAA: Chip Revision <ul style="list-style-type: none"> ▪ BAA: MLX90384 production version
Option Code for variant, including magnet type:	001: Application - Magnetic configuration <ul style="list-style-type: none"> ▪ 001: Magnet MLXMAGNT-VER-001 consisting of a magnet ring set ID14/OD24 ▪ 002: Magnet MLXMAGNT-VER-002 for 6mm shaft mounting ID06/OD24 ▪ 003: Magnet MLXMAGNT-VER-003 larger diameter Vernier magnet ID25/OD42 ▪ 004: Magnet MLXMAGNT-VER-004 single magnet ring with two tracks ID16/OD24
Packing Form:	Low volume production: TU (Tubes) <ul style="list-style-type: none"> ▪ 80 pcs/tube for TSSOP-16 package, GO code ▪ The magnets are shipped in tubes or trays Mass production: RE (Tape & Reel) <ul style="list-style-type: none"> ▪ 4500 pcs/reel for TSSOP-16 package, GO code ▪ The magnets are shipped in tubes or trays

Table 2 - Ordering Codes Information

MLX90384

Arcminaxis® Magnetic Encoder System
Datasheet



1	GENERAL DESCRIPTION	1
1.1	FEATURES & BENEFITS	1
1.2	APPLICATION EXAMPLES	1
1.3	DESCRIPTION	1
2	ORDERING INFORMATION	2
3	MLX90384 MAGNET	4
3.1	MAGNET TYPES	4
3.2	MAGNET SPECIFICATION	4
3.3	MAGNET DIMENSIONS	5
3.4	DETAILED MECHANICAL DRAWING OF MLXMAGNT-VER-001	6
3.5	DETAILED MECHANICAL DRAWING OF MLXMAGNT-VER-002	7
3.6	DETAILED MECHANICAL DRAWING OF MLXMAGNT-VER-003	7
3.7	DETAILED MECHANICAL DRAWING OF MLXMAGNT-VER-004	8
3.8	MAGNETIC FIELD SPECIFICATION	9
4	MLX90384 SENSOR CHIP	10
4.1	FUNCTIONAL BLOCK DIAGRAM	10
4.2	TSSOP-16 PACKAGE WITH SENSING SPOTS	11
4.3	PIN DESCRIPTION FOR TSSOP-16 PACKAGE	11
4.4	ABSOLUTE MAXIMUM RATINGS	12
4.5	ELECTRICAL OPERATING CONDITIONS & SPECIFICATIONS	12
5	PACKAGE, IC HANDLING AND ASSEMBLY	14
5.1	PACKAGE INFORMATION FOR TSSOP-16 PACKAGE	14
5.2	STORAGE AND HANDLING OF PLASTIC ENCAPSULATED ICs	15
5.3	ASSEMBLY OF ENCAPSULATED ICs	15
5.4	ENVIRONMENT AND SUSTAINABILITY	16
6	STANDARD INFORMATION	17
7	MLX90384 ENCODER SYSTEM	18
7.1	SYSTEM REFERENCE DESIGN	18
7.2	SYSTEM SPECIFICATION ACCORDING TO REFERENCE DESIGN	19
7.3	ENCODER SYSTEM CALIBRATION	20
8	GLOSSARY OF TERMS & REFERENCES	21
8.1	GLOSSARY	21
8.2	LIST OF TABLES	21
9	REVISION HISTORY	22
10	DISCLAIMER	23

3 MLX90384 Magnet

3.1 Magnet types

The MLX90384 magnets delivered by Melexis in the MLX90384 encoder system are Vernier type magnets with two tracks. They are made of ferrite material with a temperature coefficient of about -2000 ppm/K for the magnetic field strength.

Melexis offers the magnets in the following versions:

Magnet Type	Description
MLXMAGNT-VER-001	Magnet ring set to be mounted into a holder ID14/OD24
MLXMAGNT-VER-002	Overmolded magnet with brass bushing for direct mounting on a $\varnothing 6$ mm shaft ID06/OD24
MLXMAGNT-VER-003	Larger diameter magnet with 14/13 pole pairs ID25/OD42
MLXMAGNT-VER-004	Single magnet ring with two tracks ID16/OD24 (maximum flexibility)

Table 3 - MLX90384 Magnet type

3.2 Magnet Specification

MLXMAGNT-VER-001

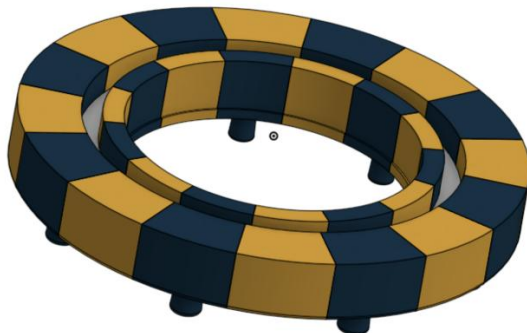

MLXMAGNT-VER-002

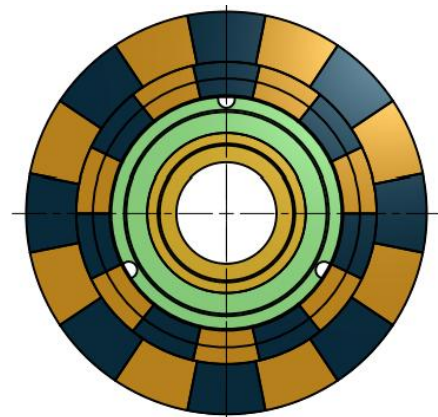

Figure 3. Magnet schematics for MLXMAGNT-VER-001 and MLXMAGNT-VER-002

The left picture shows a simplified version of magnet **MLXMAGNT-VER-001** allowing for a large inner clearance for this magnet size, whereas the right picture shows the **MLXMAGNT-VER-002** version with overmolding and an inner brass bushing for press-fit mounting on a $\varnothing 6$ mm shaft.

Due to their difference in pole-pair count, the Master and Nonius magnets **MLXMAGNT-VER-001** and **MLXMAGNT-VER-002** are manufactured separately and then assembled to form the Vernier magnet for the MLX90384 encoder system. The magnet **MLXMAGNT-VER-001** is delivered in a transport holder to keep the two Master and Nonius in place.

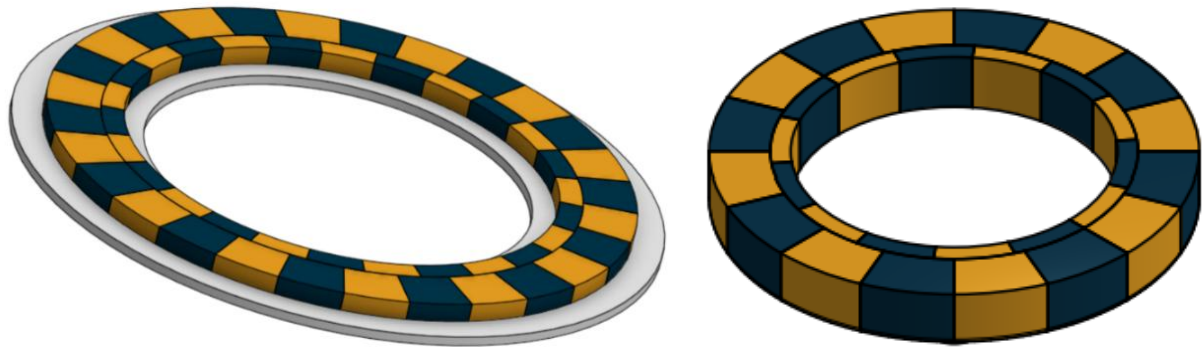

Figure 4. *Magnet schematics for MLXMAGNT-VER-003 and MLXMAGNT-VER-004*

The figure shows on the left side the **MLXMAGNT-VER-003** with the Master and the Nonius track made as one piece on top of a metal base. The 25 mm diameter inner hole allows easy pass-through of cables with connectors.

On the right side the picture shows **MLXMAGNT-VER-004**, which is the improved version of **MLXMAGNT-VER-001**. This updated design provides 2 mm more space on its inner diameter while keeping the same outer diameter. The **MLXMAGNT-VER-004** is also 1 mm thinner than its predecessor, with a single-piece design that simplifies handling and installation.

3.3 Magnet Dimensions

The dimensions of the magnets as well as the number of pole pairs Npp are presented in the table below. For comprehensive details, including manufacturing tolerances, please refer to the detailed mechanical drawings provided in subsequent sections.

Magnet #	Inner diameter ID [mm]*	Outer diameter OD [mm]*	Thickness [mm]*	Npp Master track	Npp Nonius track
MLXMAGNT-VER-001	14	24	4.5**	8	7
MLXMAGNT-VER-002	6	24	6	8	7
MLXMAGNT-VER-003	25	42	1.8	14	13
MLXMAGNT-VER-004	16	24	3.5	8	7

Table 4 - Magnet dimensions

* for tolerances, see detailed mechanical drawings

** without transport holder

3.4 Detailed mechanical drawing of MLXMAGNT-VER-001

This magnet is delivered as a 2-part ring set. For clip-mounting the magnet into a holder, inverse conical pillars that are opposite to the magnetized surface and can be used. By designing a custom holder, the user has the highest flexibility for his own encoder design. For shipping/transport the magnet is mounted on a simple support plate. For instructions how to assemble the magnet with the sensor chip, please refer to section 4.2.1.

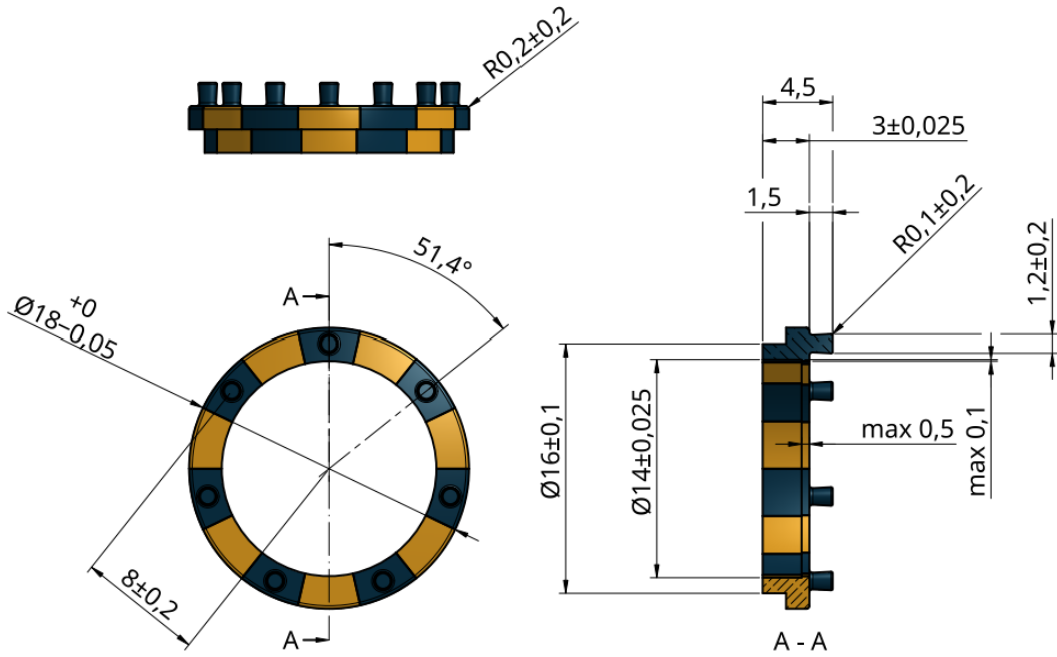

Figure 5. *Dimensions of MLXMAGNT-VER-001 Nonius. Unless specified otherwise, dimensions are millimetres.*

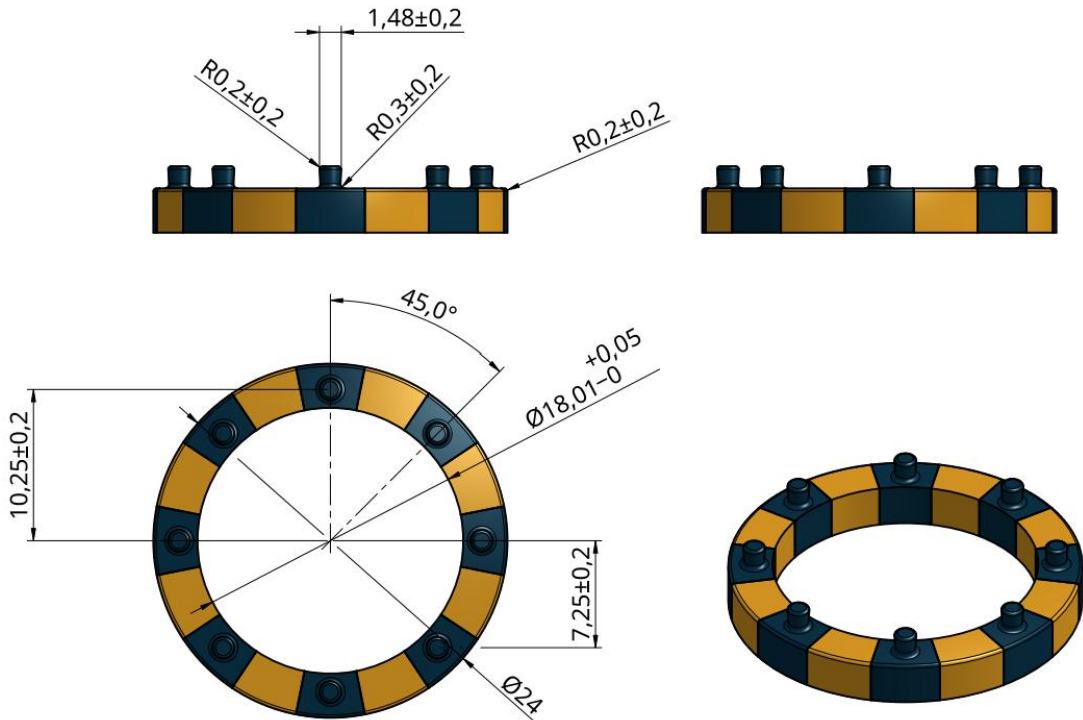

Figure 6. *Dimensions of MLXMAGNT-VER-001 Master. Unless specified otherwise, dimensions are millimetres.*

3.5 Detailed mechanical drawing of MLXMAGNT-VER-002

This magnet configuration contains a brass bushing in the center and is designed for press-fit mounting on a 6 mm shaft.

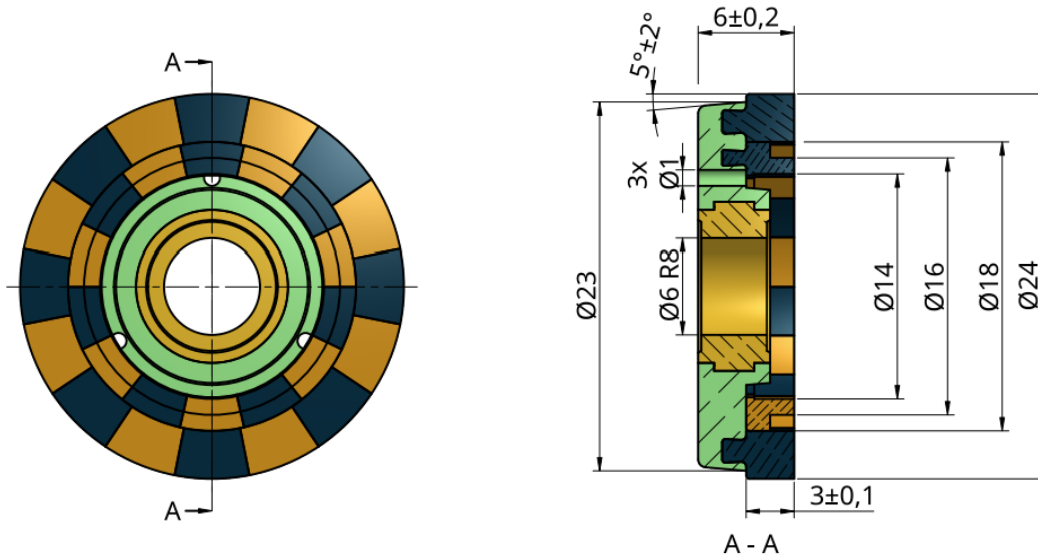

Figure 7. *Dimensions of MLXMAGNT-VER-002. Unless specified otherwise, dimensions are millimetres.*

3.6 Detailed mechanical drawing of MLXMAGNT-VER-003

This magnet is made as one piece without separation between the tracks. The inner hole of 25mm diameter allows easy pass through of cables with connectors.

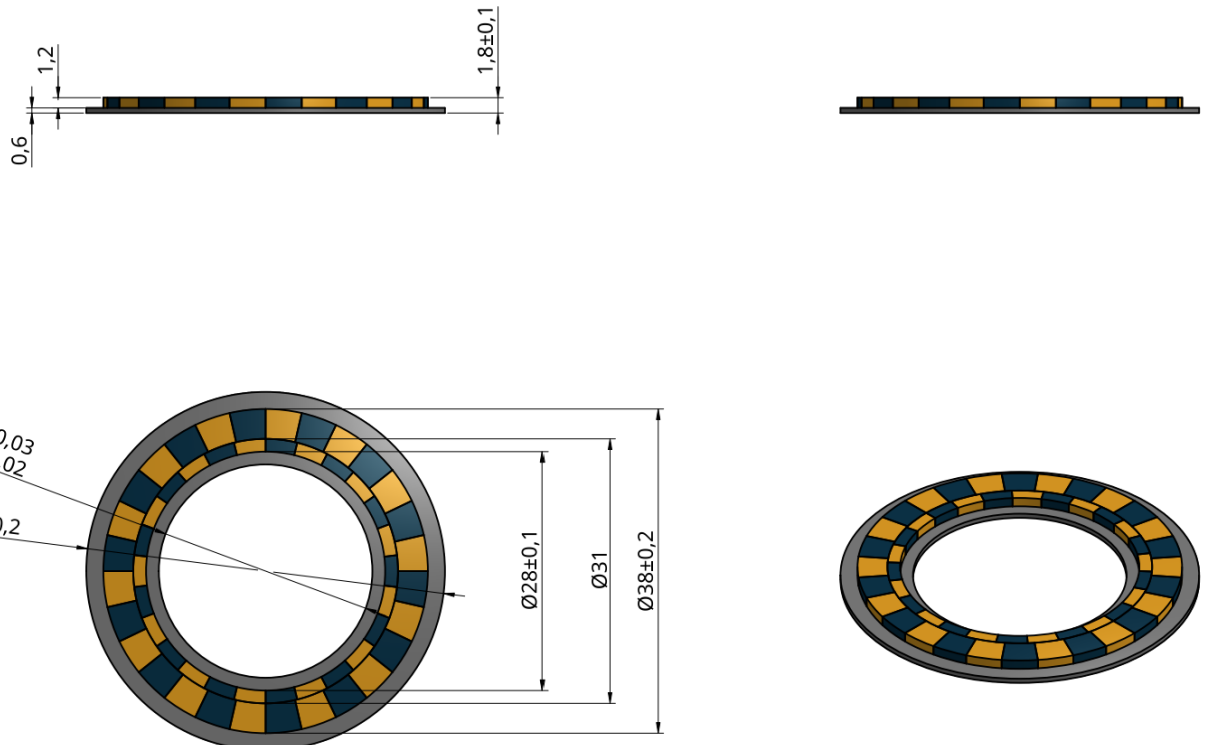

Figure 8. *Dimensions of MLXMAGNT-VER-003. Unless specified otherwise, dimensions are millimetres.*

3.7 Detailed mechanical drawing of MLXMAGNT-VER-004

MLXMAGNT-VER-004 is the improved version of **MLXMAGNT-VER-001**. This updated design is made as one piece without separation between the tracks and provides 2 mm more space on its inner diameter while keeping the same outer diameter. The **MLXMAGNT-VER-004** is also 1 mm thinner than its predecessor.

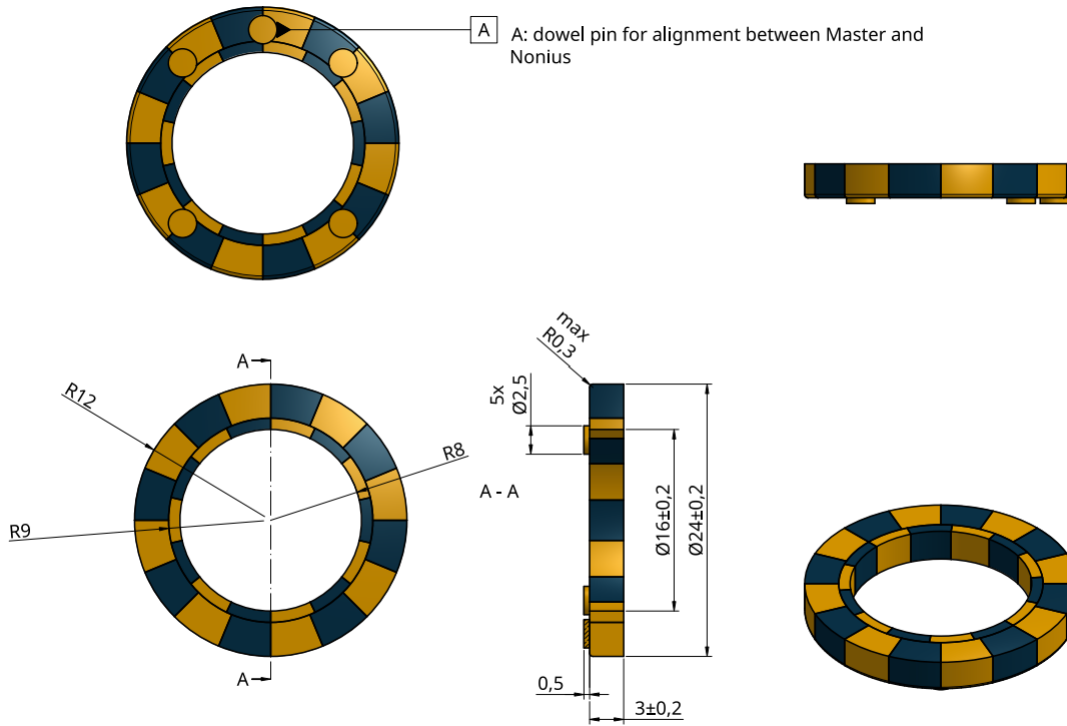

Figure 9. *Dimensions of MLXMAGNT-VER-004. Unless specified otherwise, dimensions are millimetres.*

3.8 Magnetic Field Specification

The tables below list the typical field amplitudes seen by the two sensing spots in nominal position (see Table 13) and 25°C with respect to the full magnet.

3.8.1 MLXMAGNT-VER-001 and MLXMAGNT-VER-002

	Master Sensing Spot	Nonius Sensing Spot
Axial Field Amplitude Bz	40 mT	16 mT
Tangential Field Amplitude Bx	33 mT	25 mT
Amplitude drift 35°C to -20°C	+10%	
Amplitude drift 35°C to +85°C	-10%	

Table 5 - Magnetic flux density at sensor for nominal assembly position MLXMAGNT-VER-001/-002

3.8.2 MLXMAGNT-VER-003

	Master Sensing Spot	Nonius Sensing Spot
Axial Field Amplitude Bz	27 mT	15 mT
Tangential Field Amplitude Bx	27 mT	15 mT
Amplitude drift 35°C to -20°C	+10%	
Amplitude drift 35°C to +85°C	-10%	

Table 6 - Magnetic flux density at sensor for nominal assembly position for MLXMAGNT-VER-003

3.8.3 MLXMAGNT-VER-004

	Master Sensing Spot	Nonius Sensing Spot
Axial Field Amplitude Bz	41 mT	21 mT
Tangential Field Amplitude Bx	34 mT	16 mT
Amplitude drift 35°C to -20°C	+10%	
Amplitude drift 35°C to +85°C	-10%	

Table 7 - Magnetic flux density at sensor for nominal assembly position for MLXMAGNT-VER-004

4 MLX90384 Sensor Chip

The MLX90384 sensor chip is a high-speed magnetic position sensor composed of two silicon circuits, each with a two-axis sensing spots for measuring axial and tangential field components representing the Sine and a Cosine signals of a two-track Vernier magnet.

As shown in the block diagram Figure 7, each of the sensing channels has its own Triaxis Hall sensor frontend, amplification chain, ADC and output stages.

4.1 Functional Block Diagram

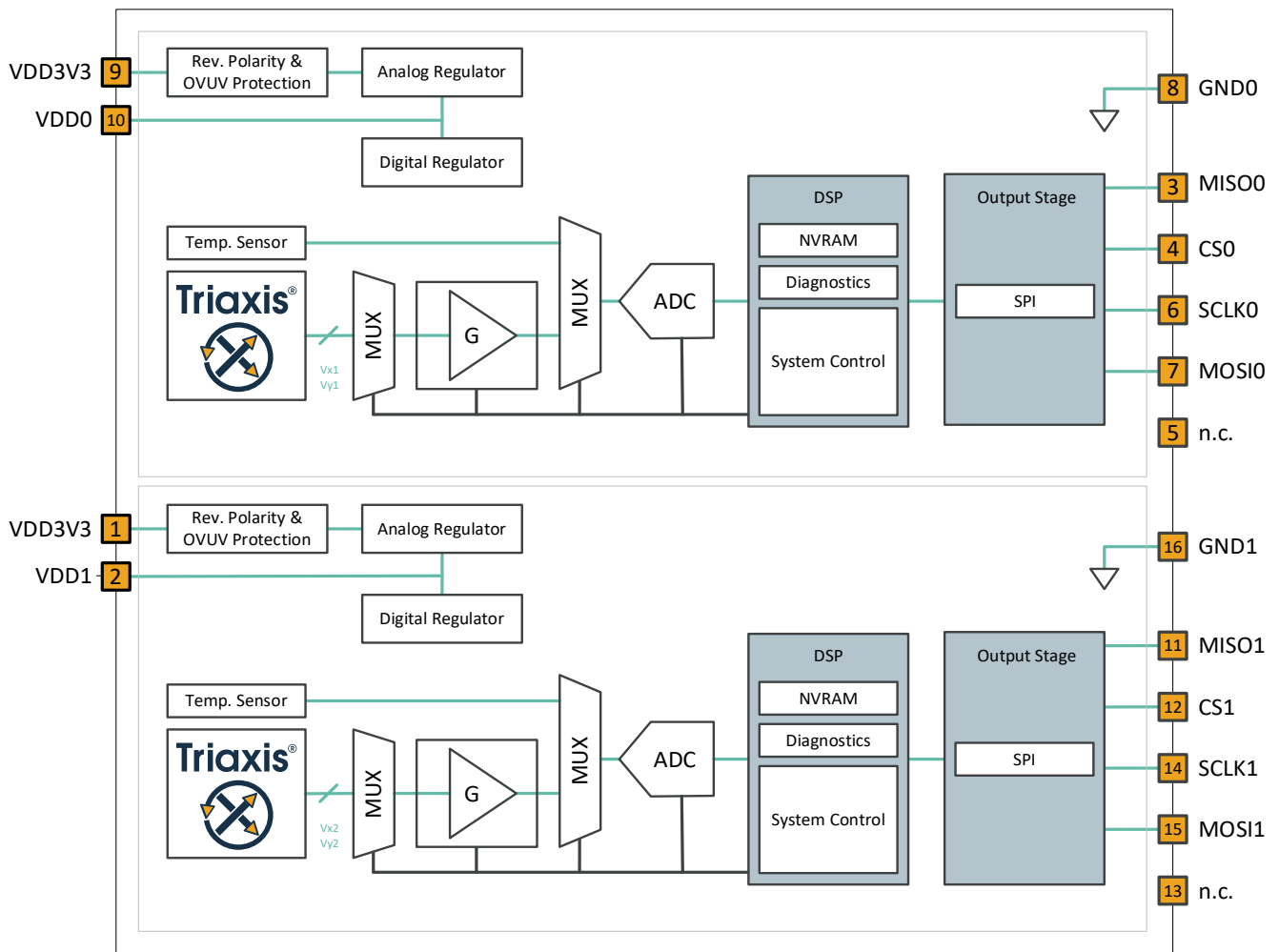

Figure 10. *TSSOP-16 Dual die block diagram*

The distance of the two sensing spots inside the package is 1.9 mm so that for nominal position, the master sensor is positioned above the center of the master track and the nonius sensor right between master and nonius track.

4.2 TSSOP-16 package with sensing spots

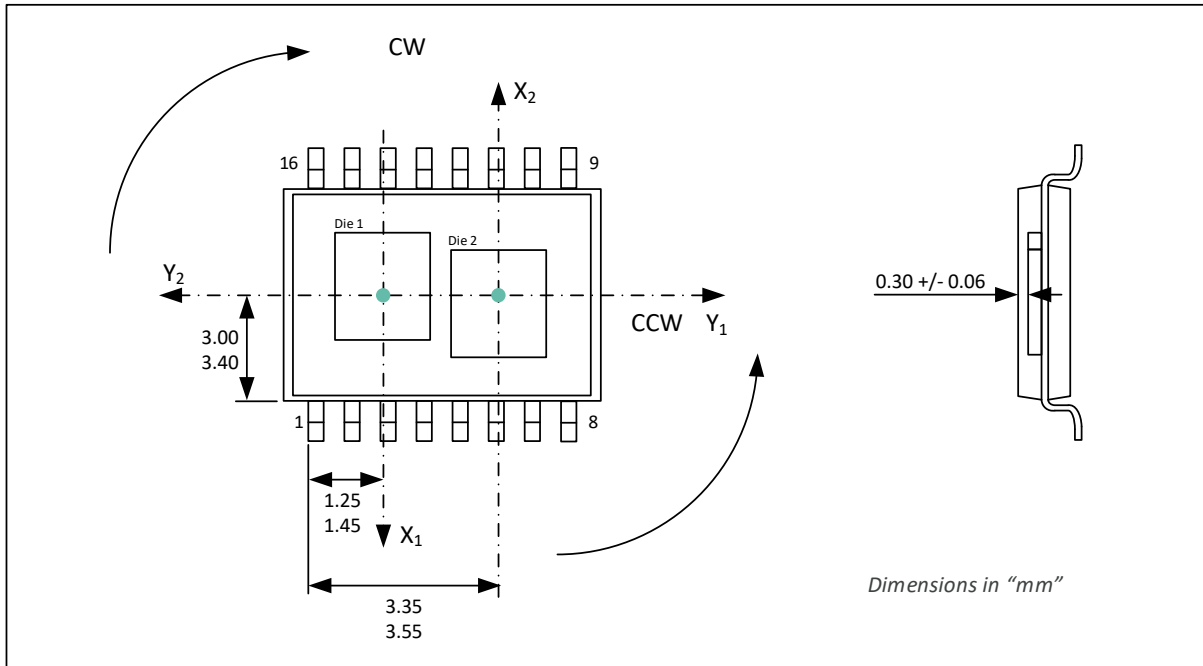
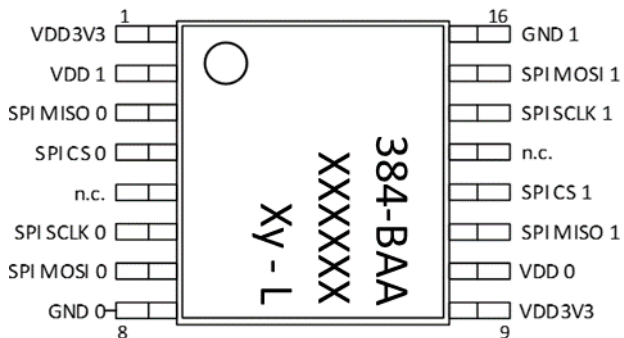

Figure 11. Indication of the locations of the two sensitivity spots for nonius track (die 1) and master track (die 2)

To build an encoder with the MLX90384 magnet and the MLX90384 sensor, additional components including a microcontroller with embedded software (delivered by Melexis) are required. The Microcontroller is communicating via the two high-speed SPI interfaces with the two sensing channels. The complete reference design is provided by the MLX90384 reference design document, separately provided by MyMelexis.

4.3 Pin description for TSSOP-16 package

For optimal EMC and ESD behavior, connect the unused pins to 'Gnd'. This interface for communication between the sensor chip and microcontroller is implemented with SPI protocol. Communication between the microcontroller and a host system is possible with SPI and SSI, for details see Application note.



Pin #	Designation	Pin#	Designation
1	VDD3V3	16	GND1
2	VDD1	15	SPI MOSI1
3	SPI MISO0	14	SPI SCLK1
4	SPI CS0	13	not connected
5	not connected	12	SPI CS1
6	SPI SCLK0	11	SPI MISO1
7	SPI MOSI0	10	VDD0
8	GND0	9	VDD3V3

Table 8 - TSSOP-16 package pinout for SPI communication

4.4 Absolute Maximum Ratings

Exceeding the absolute maximum ratings may cause permanent damage. Exposure to absolute maximum-rated conditions may affect the device reliability.

Parameter	Symbol	Min.	Max.	Unit	Condition
Supply Voltage at VDD Pin	V_{DD}	-0.3	6.0	V	
Supply Voltage at VDD3V3 Pin	V_{DD}	-0.3	4.0	V	
I/O Pin Voltage	V_{PIN}	-0.3	$V_{DD}+0.3$	V	
ESD CDM Robustness	V_{CDM}	-500	500	V	All pins, according to AEC-Q100-011
		-750	750	V	Package corner pins
ESD HBM Robustness	V_{HBM}	-2.0	2.0	kV	
Operating Temperature	T_{AMB}	-40.0	150.0	°C	
Junction Temperature	T_J		+175	°C	
Storage Temperature	T_{st}	-55	+170	°C	
Magnetic Flux Density	B_{max}	-1	1	T	

Table 9 - Absolute Maximum Ratings

Exceeding the absolute maximum ratings may cause permanent damage. Exposure to absolute maximum-rated conditions for extended periods may affect the device reliability.

4.5 Electrical operating conditions & specifications

Unless otherwise specified, the electrical specifications of the MLX90384 sensor chip are valid for a temperature range of [-20, 85] °C and specified nominal supply voltage ranges.

Parameter	Symbol	Min.	Typ.	Max.	Unit	Condition
Supply Voltage	V_{DD}	3	3.3	3.6	V	Pins VDD3V3 & VDD0/VDD1 shorted
Supply tolerance	ΔV_{DD}	-5		+5	% V_{DD}	
Supply Current*	I_{DD}			20.0	mA	excluding output I/F

Table 10 - Electrical operating conditions in 3.3 V operating mode

*the supply current is for the MLX90384 sensor chip without the additional microcontroller required for the encoder system

4.5.1 Input channel specification

The specification for the input channels of the MLX90384 sensor chip are as follows:

Parameter	Symbol	Min.	Typ.	Max.	Unit	Condition
Input Low Voltage Detection Level		25.0	35.0	42.0	% V_{DD}	
Input High Voltage Detection Level		52.0	60.0	75.0	% V_{DD}	
Input Hysteresis Level		18.0	25.0	42.0	% V_{DD}	
Input Voltage Range		0		100	% V_{DD}	

Table 11 - Input channel specifications

4.5.2 Output channel specification

The output driver for the MISO output pin is configured by default in push/pull mode with the specifications described below. Each output pin voltage ranges from 0 V to VDD external supply. The rise and fall time specifications are listed in the following table.

Parameter	Symbol	Min.	Typ.	Max.	Unit	Condition
Rise/Fall Time Push-Pull Mode	$T_{\text{rise_fall_pp}}$	3.3		15.0	ns	LH or HL from 75 % VDD to 25 % VDD for 50 pF load in 5 V mode
		4.0		18.0	ns	LH or HL from 75 % VDD to 25 % VDD for 50 pF load in 3.3 V mode

Table 12 - Interface output timing specifications for 50pF load

4.5.3 SPI Clock Frequency Specifications

This section is describing the SPI clock frequency used between the STM32 microcontroller and the MLX90384 sensor chip. The nominal value is the frequency used by the software of the STM32 microcontroller.

This communication is handled by the STM32 micro controller indicated in the reference design.

The capacitance C_L refers to the max. load on the signal wire.

Parameter	Symbol	Min.	Typ.	Max.	Unit	Condition
SPI Clock Frequency	f_{SCLK}		6.3		MHz	$C_L \leq 50 \text{ pF}, f_{ac} \geq 2f_{\text{SCLK}}$

Table 13 - SPI Timing Specification

5 Package, IC handling and assembly

5.1 Package information for TSSOP-16 package

5.1.1 Package dimensions

The following drawing indicates the dimensions of the MLX90384 Sensor package

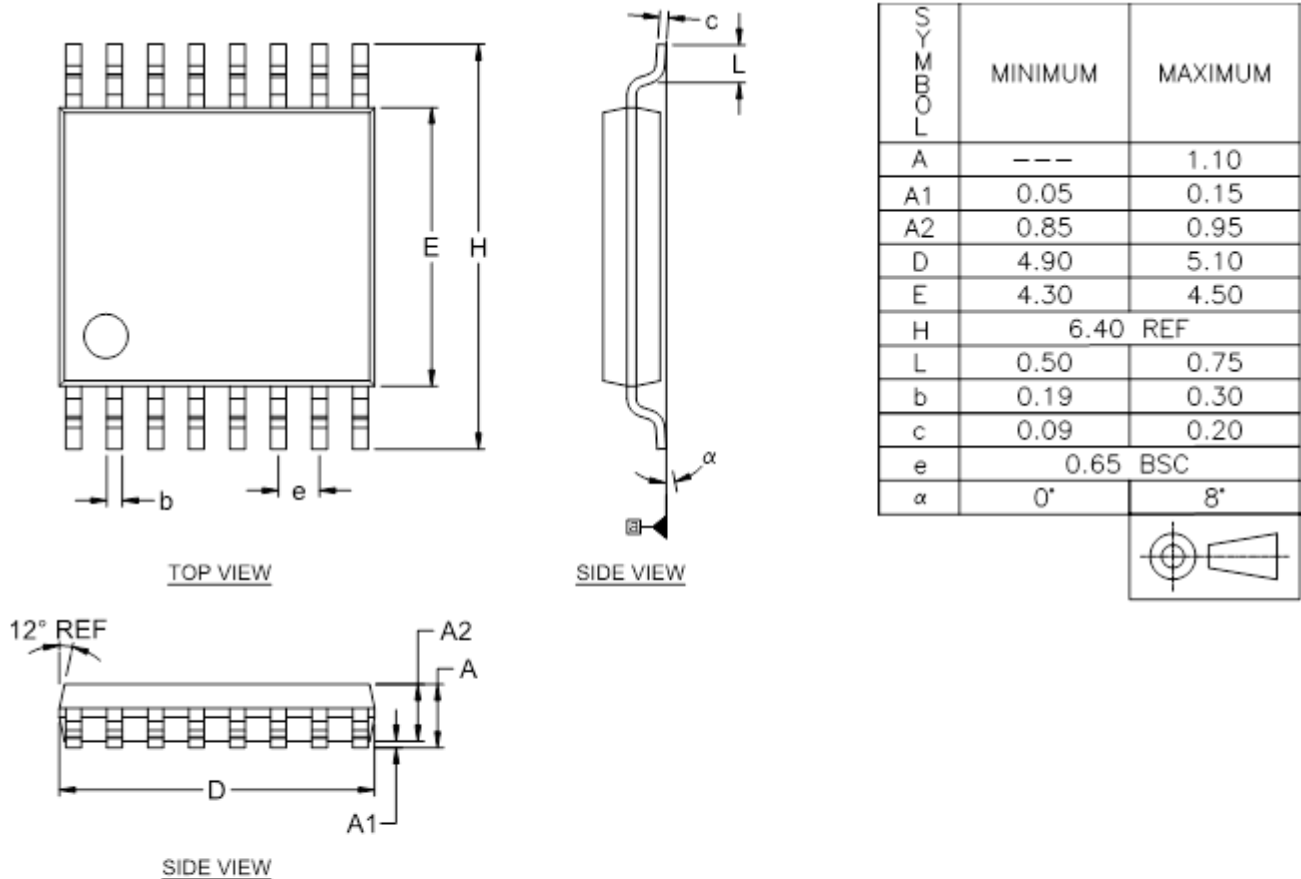

NOTE :

1. ALL DIMENSIONS IN MILLIMETERS (mm) UNLESS OTHERWISE STATED.
2. DIMENSION D DOES NOT INCLUDE MOLD FLASH, PROTRUSIONS OR GATE BURRS OF MAX 0.15 mm PER SIDE.
3. DIMENSION E DOES NOT INCLUDE INTERLEADS FLASH OR PROTRUSIONS OF MAX 0.25 mm PER SIDE.
4. DIMENSION b DOES NOT INCLUDE DAMBAR PROTRUSION OF MAX 0.08 mm.
5. LEAD TO LEAD COPLANARITY MAX 0.100 MILLIMETERS (mm) WITH RESPECT TO SEATING PLANE α .

Figure 12. MLX90384 TSSOP-16 package dimensions

5.1.2 TSSOP-16 package pinout and package marking

The drawing below shows the package pinout and marking.

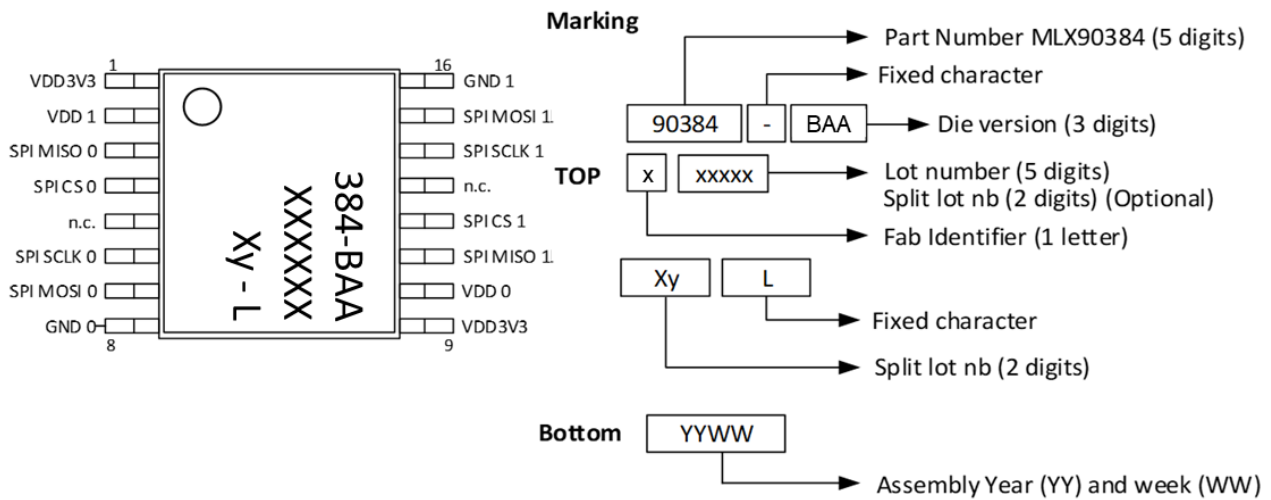

Figure 13. *The package indicates the part and lot # for full traceability and identification*

5.2 Storage and handling of plastic encapsulated ICs

Plastic encapsulated ICs shall be stored and handled according to their MSL categorization level (specified in the packing label) as per J-STD-033. Electronic semiconductor products are sensitive to Electro Static Discharge (ESD). The component assembly shall be handled in EPA (Electrostatic Protected Area) as per ANSI S20.20 For more information refer to Melexis [Guidelines for storage and handling of plastic encapsulated ICs](#) ^(a)

5.3 Assembly of encapsulated ICs

For Surface Mounted Devices (SMD, as defined according to JEDEC norms), the only applicable soldering method is reflow.

For Through Hole Devices (THD), the applicable soldering methods are reflow, wave, selective wave and robot point-to-point. THD lead pre-forming (cutting and/or bending) is applicable under strict compliance with Melexis [Guidelines for lead forming of SIP Hall Sensors](#) ⁽²⁾.

Melexis products soldering on PCB should be conducted according to the requirements of IPC/JEDEC and J-STD-001. Solder quality acceptance should follow the requirements of IPC-A-610.

For PCB-less assembly refer to the relevant application notes ⁽²⁾ or contact Melexis.

Electrical resistance welding or laser welding can be applied to Melexis products in THD and specific PCB-less packages following the [Guidelines for welding of PCB-less devices](#) ⁽²⁾.

^a www.melexis.com/ic-handling-and-assembly

MLX90384

Arcminaxis® Magnetic Encoder System
Datasheet



Environmental protection of customer assembly with Melexis products for harsh media application, is applicable by means of coating, potting or overmolding considering restrictions listed in the relevant application notes ⁽²⁾

For other specific process, contact Melexis via www.melexis.com/technical-inquiry

5.4 Environment and sustainability

Melexis is contributing to global environmental conservation by promoting non-hazardous solutions. For more information on our environmental policy and declarations (RoHS, REACH...) visit www.melexis.com/environmental-forms-and-declarations

6 Standard Information

Our products are classified and qualified regarding soldering technology, solderability and moisture sensitivity level according to standards in place in Semiconductor industry.

For further details about test method references and for compliance verification of selected soldering method for product integration, Melexis recommends reviewing on our web site the General Guidelines soldering recommendation. For all soldering technologies deviating from the one mentioned in above document (regarding peak temperature, temperature gradient, temperature profile, etc.), additional classification and qualification tests have to be agreed upon with Melexis.

For package technology embedding trim and form post-delivery capability, Melexis recommends to consult the dedicated trim & form recommendation application note: lead trimming and forming recommendations.

7 MLX90384 Encoder System

The MLX90384 magnet and sensor chip are key components to realize a high accuracy/resolution encoder rpm system with a nominal 1.5 mm airgap between sensor and magnet for a temperature range from -20 °C to 85 °C. This section illustrates such a possible system by the Melexis reference design.

7.1 System Reference Design

The encoder reference design shown in Figure 13 uses the three elements delivered by Melexis: The magnet, the sensor chip and the software for the microcontroller. All other components must be provided by the customer. A detailed description of the reference design including full PCB schematics and component list is provided by the MLX90384 Reference design document distributed separately by MyMelexis.

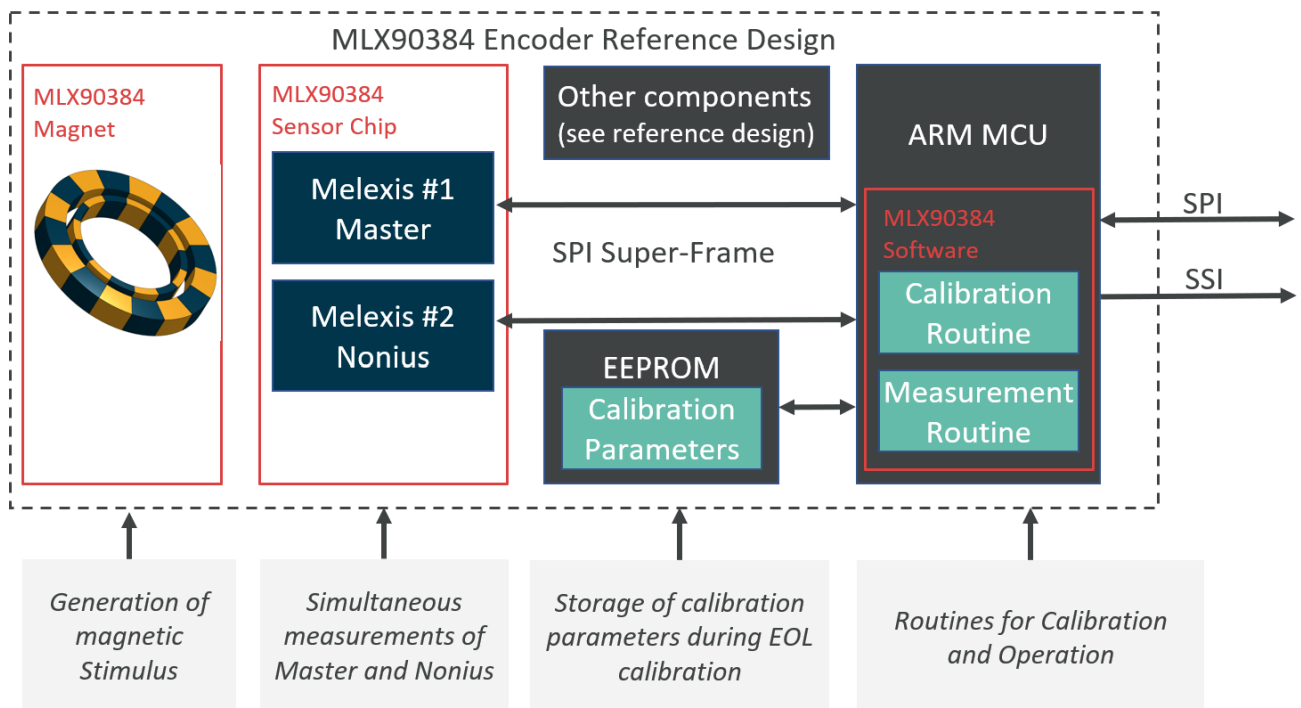

Figure 14. *Encoder Reference Design with red marked items delivered by Melexis as product MLX90384*

Besides the accuracy of the encoder system, which depends substantially on the calibration process performed in the application and which is typically 0.1 degrees or smaller*, many applications also require very high angular resolution.

Following the reference design, a resolution of up to 18 bits with a maximum rotation speed for the magnet of 5000 rpm can be reached.

The MLX90384 sensor module supports both SPI and differential SSI interfaces. SPI is used for both communication and output, enabling configuration and data retrieval. SSI, on the other hand, provides data output, offering a robust method for transmitting measured values. Refer to the Application Note for detailed implementation.

*The accuracy can also be influenced by stray fields as well as temperature changes and dynamic wear out effects of the overall system.

7.2 System Specification according to Reference Design

7.2.1 Assembly Specification

The installation of the encoder system is done by mounting the magnet on a rotating shaft, mounting the sensor module (readhead) at the right position with respect to the magnet and connecting it to the SPI host controller.

Due to the Melexis Triaxis technology, the requirements for the initial position of the sensor module versus the magnet are substantially relaxed compared with most other magnetic encoder systems on the market.

The picture below shows the three orthogonal dimensions to be respected when placing the sensor chip with respect to the magnet: the radial position x_s , the tangential position t_s and the airgap z_s .



Figure 15. *Assembly position of magnet and sensor chip. The chip is mounted with Pins #1 and 16 towards the ring center.*

For each of those dimensions a tolerance of +/-0.5mm must be respected, as indicated in the table below.

Parameter	Description	Min.	Nom.	Max.	Unit
Sensor radial position (x_s)	The position of the center of the sensor chip as distance from the magnet center.	9.0	9.5	10.0	mm
Sensor tangential position (t_s)	The position of the center of the sensor as distance from the ideal tangential position.	-0.5	0	0.5	mm
Air gap (z_s)	Distance between the top of the package and the magnet.	1.0	1.5	2.0	mm

Table 14 - *Assembly Position and Tolerances for MLXMAGNT-VER-001/-002/-004*

Parameter	Description	Min.	Nom.	Max.	Unit
Sensor radial position (x_s)	The position of the center of the sensor chip as distance from the magnet center.	16	16.5	17	mm
Sensor tangential position (t_s)	The position of the center of the sensor as distance from the ideal tangential position.	-0.5	0	0.5	mm
Air gap (z_s)	Distance between the top of the package and the magnet.	1.0	1.5	2.0	mm

Table 15 - *Assembly Position and Tolerances for MLXMAGNT-VER-003*

The assembly specifications given in this table guarantee

- a) the magnetic operating range for the sensor chip over the full temperature range from -20degC to +85degC.
- b) the system calibration with the software package running on the microcontroller

7.2.2 System Angular Speed

The encoder system works at angular speed between standstill and 5000 rpm.

The system update rate and intrinsic delay by the integrated signal and data processing are as follows

Parameter	Symbol	Min.	Typ.	Max.	Unit	Condition
Angle update interval	t_{update}		45		μs	without window filtering
Signal and data processing time	$t_{process}$		55		μs	Magnetic angle to SPI output

Table 16 - System Speed Specifications valid for all magnets

When the window average filter is used, the update interval remains the same, but due to the averaging, the history of the magnetic angle increases linearly with the number of averaged samples.

7.2.3 System Angular Resolution

The following graph compares the typically measured angular resolution versus the theoretical one. The values are given in bit RMS versus the programmed sample integration at room temperature and for nominal airgap. For each doubling of the averaged samples, the resolution increases by half a bit.

With an integration step of $15 \mu s$ and the number of integrated samples n_{int} the integration time t_{int} is calculated by $t_{int} = n_{int} * 15 \mu s$. For very fast readings without any sample integration the resolution is about 15 bit whereas for about 1.5 ms integration time a resolution of 18 bits is reached.

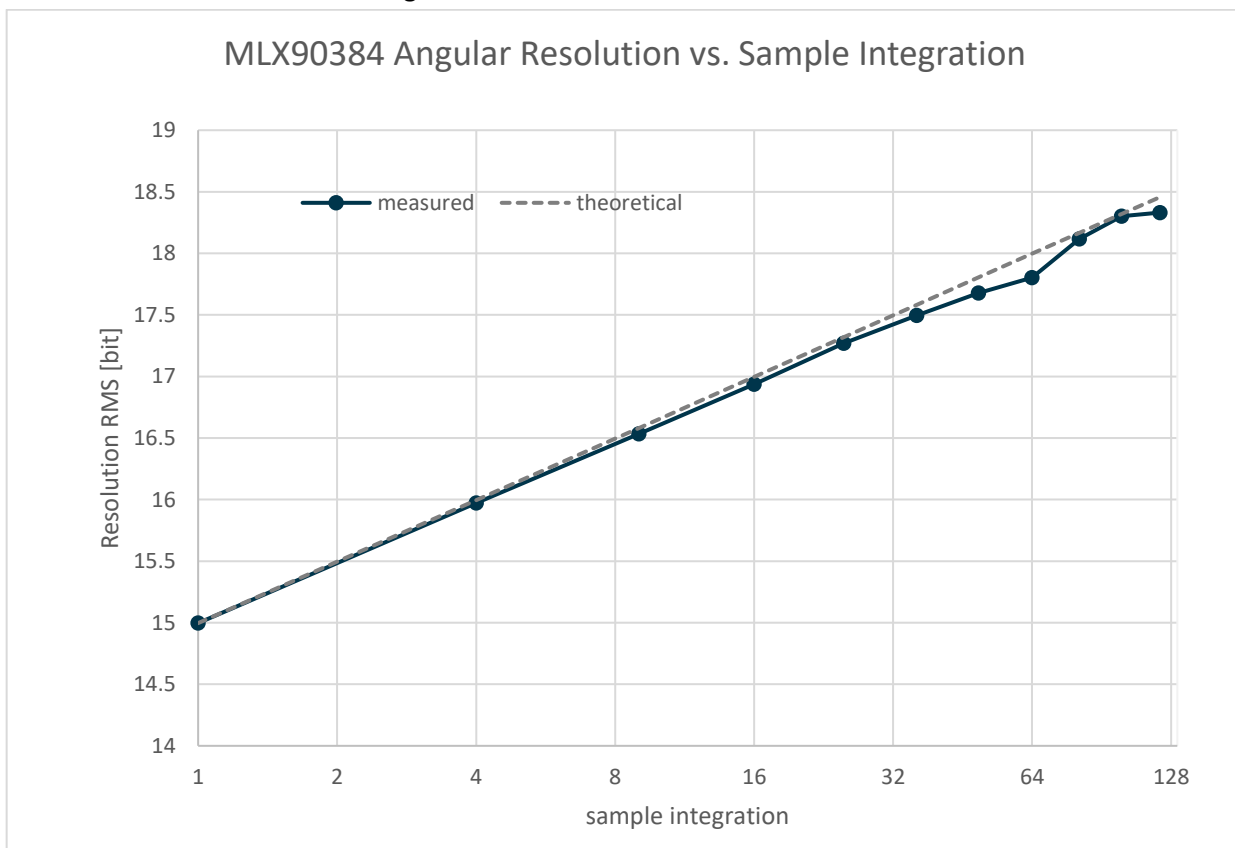

Figure 16. Angular Resolution vs. Integration time (programmable) for the MLX90384 encoder system

7.3 Encoder System Calibration

To deliver accurate angle and speed information, the encoder system must be calibrated by the customer after assembly.

Please refer to **MLX90384 Application Note** for details about the calibration.

8 Glossary of terms & references

8.1 Glossary

Term	Description
NC	Not Connected
ID/OD	Inner Diameter/Outer Diameter

Table 17 - Glossary

8.2 List of tables

Table 1 - MLX90384 Order Codes2

Table 2 - Ordering Codes Information2

Table 3 - MLX90384 Magnet type4

Table 4 - Magnet dimensions5

Table 5 - Magnetic flux density at sensor for nominal assembly position MLXMAGNT-VER-001/-0029

Table 6 - Magnetic flux density at sensor for nominal assembly position for MLXMAGNT-VER-0039

Table 7 - Magnetic flux density at sensor for nominal assembly position for MLXMAGNT-VER-0049

Table 8 - TSSOP-16 package pinout for SPI communication 11

Table 9 - Absolute Maximum Ratings 12

Table 10 - Electrical operating conditions in 3.3 V operating mode 12

Table 11 - Input channel specifications 12

Table 12 - Interface output timing specifications for 50pF load 13

Table 13 - SPI Timing Specification 13

Table 14 - Assembly Position and Tolerances for MLXMAGNT-VER-001/-002/-004 19

Table 15 - Assembly Position and Tolerances for MLXMAGNT-VER-003 19

Table 16 - System Speed Specifications valid for all magnets 20

Table 17 - Glossary 21

Table 18 - Revision history 22

9 Revision history

Revision	Date	Change history
1.0	18-Oct-2024	Initial Version
2.0	26-Nov-2025	SSI interface, magnet 3 and 4 added, magnet drawings updated, switch from OAA to BAA samples, Chapter order adjusted

Table 18 - Revision history

10 Disclaimer

The content of this document is believed to be correct and accurate. However, the content of this document is furnished "as is" for informational use only and no representation, nor warranty is provided by Melexis about its accuracy, nor about the results of its implementation. Melexis assumes no responsibility or liability for any errors or inaccuracies that may appear in this document. Customer will follow the practices contained in this document under its sole responsibility. This documentation is in fact provided without warranty, term, or condition of any kind, either implied or expressed, including but not limited to warranties of merchantability, satisfactory quality, non-infringement, and fitness for purpose. Melexis, its employees and agents and its affiliates' and their employees and agents will not be responsible for any loss, however arising, from the use of, or reliance on this document. Notwithstanding the foregoing, contractual obligations expressly undertaken in writing by Melexis prevail over this disclaimer.

This document is subject to change without notice, and should not be construed as a commitment by Melexis. Therefore, before placing orders or prior to designing the product into a system, users or any third party should obtain the latest version of the relevant information.

Users or any third party must determine the suitability of the product described in this document for its application, including the level of reliability required and determine whether it is fit for a particular purpose.

This document as well as the product here described may be subject to export control regulations. Be aware that export might require a prior authorization from competent authorities. The product is not designed, authorized or warranted to be suitable in applications requiring extended temperature range and/or unusual environmental requirements. High reliability applications, such as medical life-support or life-sustaining equipment or avionics application are specifically excluded by Melexis. The product may not be used for the following applications subject to export control regulations: the development, production, processing, operation, maintenance, storage, recognition or proliferation of:

- 1. chemical, biological or nuclear weapons, or for the development, production, maintenance or storage of missiles for such weapons;*
- 2. civil firearms, including spare parts or ammunition for such arms;*
- 3. defense related products, or other material for military use or for law enforcement;*
- 4. any applications that, alone or in combination with other goods, substances or organisms could cause serious harm to persons or goods and that can be used as a means of violence in an armed conflict or any similar violent situation.*

No license nor any other right or interest is granted to any of Melexis' or third party's intellectual property rights.

If this document is marked "restricted" or with similar words, or if in any case the content of this document is to be reasonably understood as being confidential, the recipient of this document shall not communicate, nor disclose to any third party, any part of the document without Melexis' express written consent. The recipient shall take all necessary measures to apply and preserve the confidential character of the document. In particular, the recipient shall (i) hold document in confidence with at least the same degree of care by which it maintains the confidentiality of its own proprietary and confidential information, but no less than reasonable care; (ii) restrict the disclosure of the document solely to its employees for the purpose for which this document was received, on a strictly need to know basis and providing that such persons to whom the document is disclosed are bound by confidentiality terms substantially similar to those in this disclaimer; (iii) use the document only in connection with the purpose for which this document was received, and reproduce document only to the extent necessary for such purposes; (iv) not use the document for commercial purposes or to the detriment of Melexis or its customers. The confidentiality obligations set forth in this disclaimer will have indefinite duration and in any case, they will be effective for no less than 10 years from the receipt of this document.

This disclaimer will be governed by and construed in accordance with Belgian law and any disputes relating to this disclaimer will be subject to the exclusive jurisdiction of the courts of Brussels, Belgium.

The invalidity or ineffectiveness of any of the provisions of this disclaimer does not affect the validity or effectiveness of the other provisions.

The previous versions of this document are repealed.

*Melexis © - No part of this document may be reproduced without the prior written consent of Melexis. (2025)
IATF 16949 and ISO 14001 Certified*

Happy to help you! www.melexis.com/contact