

Time-of-flight basics

Contents

1. Introduction	2
2. Glossary of Terms	3
3. Recovering phase from cross-correlation	4
4. Time-of-flight operating principle: the lock-in amplifier	6
5. The time-of-flight sensor pixel	6
6. Time-of-flight performance parameters	8
7. Time-of-flight optical parameters	9
8. Unambiguous range and aliasing	10
9. Distance offset.....	11
10. Performance comparison between time-of-flight, stereo vision and structured light.....	13
11. Melexis ToF Evaluation Kits	14

1. Introduction

The development of automation in all the fields of industry and also on the consumer market is related to the development of technologies to make a machine aware of its environment and its position in that environment. This three dimensional environment awareness is achieved by using what is called 3D vision technologies. A number of different technologies are available today for 3D vision and we can distinguish mainly three operating principles: structured light, stereovision and time of flight.

Structured light works by projecting a known pattern onto a scene, then observing the way this pattern is deformed, giving us information to determine distance. However this technology has limitations especially in bright sunlight conditions or when high resolution is needed as it requires some really expensive and bulky projectors and a lot of computation afterwards to get the distance data.

Stereo vision is based on the use of two cameras which need to be accurately positioned relative to each other. When correlating the two images it is possible to generate a depth-map. The main advantage of this technology for 3D vision is the relatively low cost of the sensors and a good resolution but it depends a lot on the lighting conditions of the observed scene. Unfortunately it requires a high processing cost, which results in strong heat dissipation. Secondly it requires significant space in a module due to the distance between the two sensors and the two lenses.

Indirect Time of flight technology works by illuminating a scene using modulated light and measuring the phase delay of the returning light after it has been reflected by the objects in the scene. The phase delay is then measured and converted to distance using a quadrature sampling technique. The advantages of this technology are high frame rate due to low computation required, a small footprint and a relatively low cost.

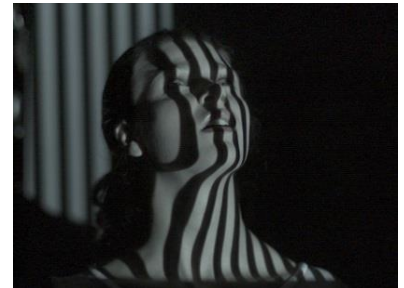

Figure 1 : Structured light illustration (USC Institute for Creative Technologies)

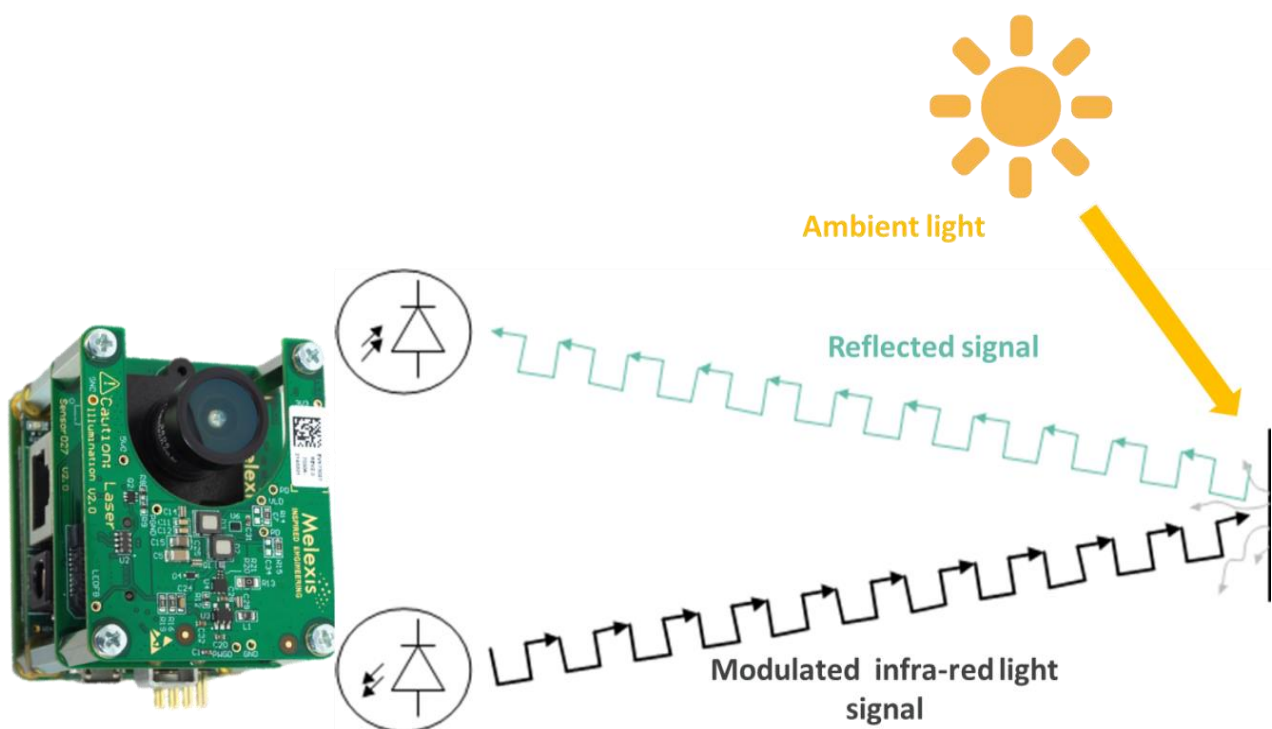

Figure 2 : Time-of-flight principle illustrated with a Melexis' EVK75027-110-940-2

2. Glossary of Terms

Term	Definition
Dark noise	Variation of the number of electrons collected at the pixel taps, independent of ambient light or active illumination
Demodulation contrast	Ratio of the differential and total charge collected on taps A and B of a pixel. Ideally 100% but in reality it decreases with modulation frequency.
Full well capacity	Defines the amount of charges a pixel can hold before being saturated. Important for sunlight robustness.
Integration time	The duration of the photo-charge collection by the sensor and also the duration of the time when the modulated light is sent with the illumination. Also called “exposure time”.
Modulation frequency	The frequency at which the illumination and the ToF pixels are modulated.
Motion robustness	The ability of a ToF camera to be able to track moving objects with precision and with a high enough framerate to recognize gesture, perform dynamic mapping, etc.
Photon shot noise	Electronic noise coming from the external light and distributed following a Poisson law, related to the particle nature of light.
Quantum efficiency	Ratio between the number of photo-electrons generated in the active area of a detector, and the number of photons impinging on it.
Responsivity	Measure of the electrical current output per unit of optical power input. Closely related to quantum efficiency.
Taps	The two taps of a ToF camera pixel are the two nodes where the photo-charges are collected depending on the demodulation signals on opposite phase DMIX0 and DMIX1.
Aliasing	Repetition of the distances measured with a ToF sensor, related to the unambiguous range. This depends on the modulation frequency used by the light source.

3. Recovering phase from cross-correlation

To recover the phase from the returning modulated signal mathematically, cross-correlation will be used. The cross-correlation of 2 signals $a(t)$ and $b(t)$ is defined as:

$$\begin{aligned}\varphi_{sg}(\tau) &= a(t) \otimes b(t) \\ &= \lim_{T \rightarrow \infty} \frac{1}{T} \int_{-\frac{T}{2}}^{\frac{T}{2}} a(t) * b(t + \tau) dt\end{aligned}$$

To illustrate the measurement procedure to retrieve the phase and amplitude information φ, a out of the reflected signal $r(t)$, we model the reflection as a simple harmonic function and the demodulation signal $d(t)$ by a cosine. Then the cross-correlation function can be reduced to a simple cosine expression with a phase delay:

$$\begin{aligned}r(t) &= 1 + a * \cos(\omega t - \varphi) \\ d(t) &= \cos(\omega t) \\ \varphi_{sg}(\tau) &= \lim_{T \rightarrow \infty} \frac{1}{T} \int_{-\frac{T}{2}}^{\frac{T}{2}} [1 + a \cdot \cos(\omega t - \varphi)] \cdot [\cos(\omega t + \omega \tau)] dt \\ &= \frac{a}{2} \cdot \cos(\varphi + \omega \tau)\end{aligned}$$

Then if we sample the correlation function at equals steps over one period, for example by changing the illumination phase in steps of 90 degrees, this correlation function will yield four different terms:

$$\omega \tau_0 = 0^\circ, \quad \omega \tau_{90} = 90^\circ, \quad \omega \tau_{180} = 180^\circ, \quad \omega \tau_{270} = 270^\circ$$

Cross-correlation terms become:

$$c(\tau_0) = \frac{a}{2} \cos(\varphi), \quad c(\tau_{90}) = \frac{a}{2} \sin(\varphi), \quad c(\tau_{180}) = -\frac{a}{2} \cos(\varphi), \quad c(\tau_{270}) = -\frac{a}{2} \sin(\varphi)$$

All these terms can be combined to calculate phase:

$$\varphi = \tan^{-1} \left(\frac{c(\tau_{270}) - c(\tau_{90})}{c(\tau_0) - c(\tau_{180})} \right)$$

And amplitude or “confidence”:

$$a = \frac{\sqrt{[c(\tau_{270}) - c(\tau_{90})]^2 + [c(\tau_0) - c(\tau_{180})]^2}}{2}$$

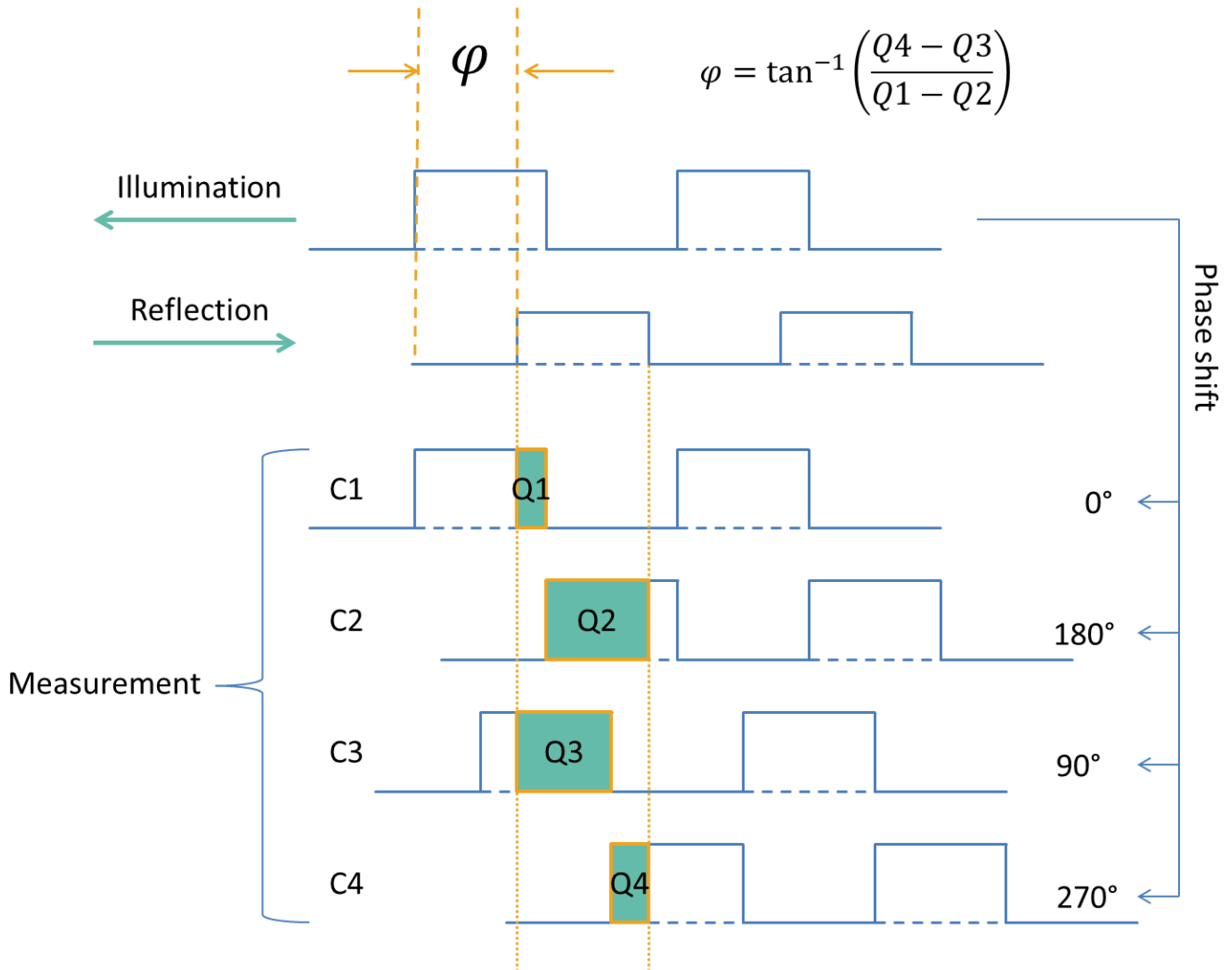

$$Distance = \frac{c}{2f_{mod}} \times \frac{\varphi}{2\pi}$$

$$Amplitude = \sqrt{(Q1 - Q2)^2 + (Q4 - Q3)^2}$$

Figure 3 : By sampling electrical charges accumulated during the measurements and using different phase shifts we can calculate the distance and signal amplitude. Doing that in parallel for all the pixels will give us a depth and confidence image.

4. Time-of-flight operating principle: the lock-in amplifier

The Melexis time-of-flight (ToF) sensor uses “lock-in” detection with active light modulation based on the principle of the lock-in amplifier as shown in Figure 4.

This type of amplifier can extract a signal with a known carrier wave even if it is coming from a noisy environment. In time-of-flight the modulated light used for illumination is the carrier wave and it can be extracted from the noisy reflected signal embedding a lot of ambient light noise.

We can make a parallel between the use of the lock-in amplifier and the cross-correlation calculations, thus using this amplifier will allow us to calculate the 4 different phase-shifted signals to recover the distance data.

Again here, by applying a fixed phase delay of 0, 180, 90 and then 270 degrees between the illumination source and the TOF pixel modulation signal, the correlation function will give four terms that can be combined to find the distance and amplitude information.

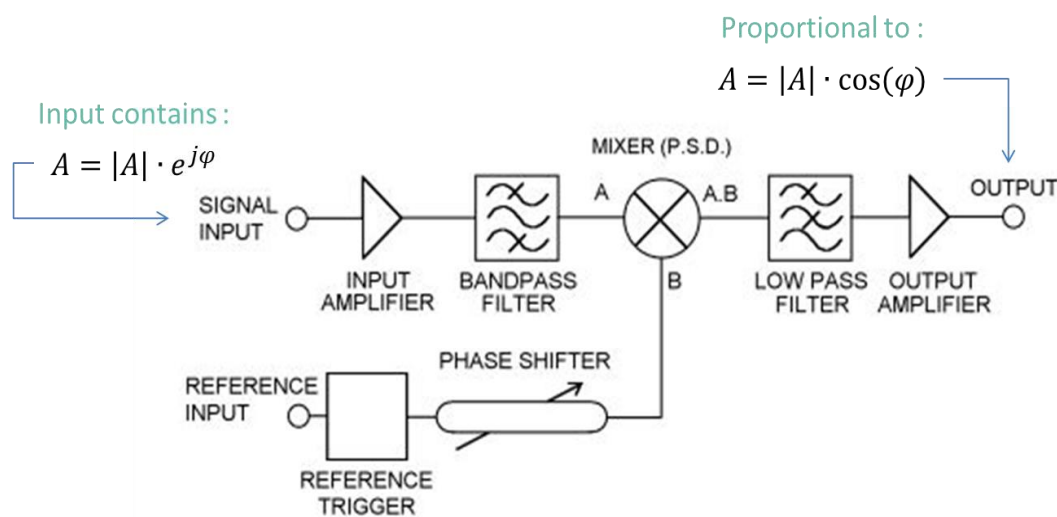

Figure 4 : Lock-in amplifier principle used in the Melexis ToF pixel.

The full system, including the environment, the optics, the illumination phase control and the lock-in detection chain per pixel, therefore looks like Figure 5. The MLX75027 TOF sensor integrates 307200 (640 x 480) of such pixels.

5. The time-of-flight sensor pixel

All the pixels in the ToF sensor are controlled by a demodulation input signal which is synchronized with the modulation of the illumination block. Each pixel can be then approximated following the model on Figure 6. Each measurement is split into different steps:

1. **Reset:** During reset time, the pixels will be reset to a known voltage value.
2. **Integration time:** During integration time, the current from the photodiode will be directed towards one of the two taps: A or B, controlled by the demodulation signal DMIX0 or DMIX1, making the electrical charges being collected respectively at taps A and B.

3. **Readout time:** During this time the demodulation is stopped and the entire array of pixels will be read following a programmed sequence.

In a 4-phase sequence, the measurement procedure has to be repeated 4 times, one for each of the 4 phase shifts in order to calculate a depth frame. This is depicted in Figure 7.

The idle time between two phase measurements, either between the readout of the information and the next integration time or between the cooldown of the illumination and the next integration time (white areas in the timings on Figure 7) should be kept as small as possible to minimize motion artifacts or to maximize framerate. The smaller the idle time is the better will the framerate be.

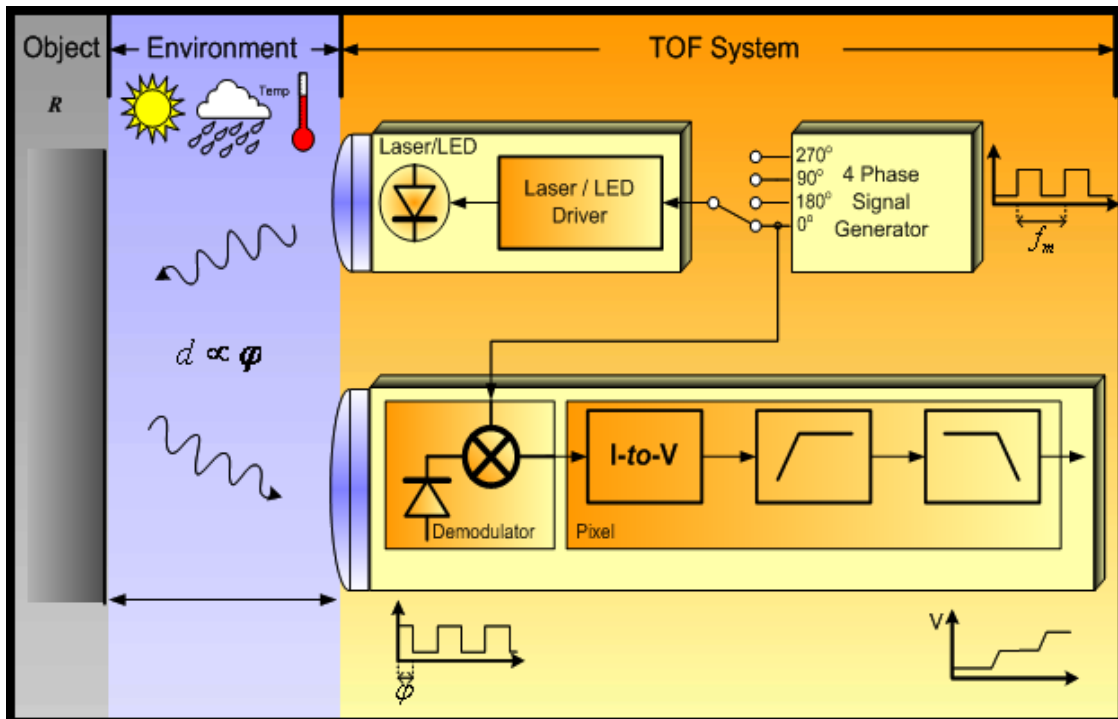

Figure 6 : Overview of the entire ToF system, including the illumination unit and the signal generator with phase shift.

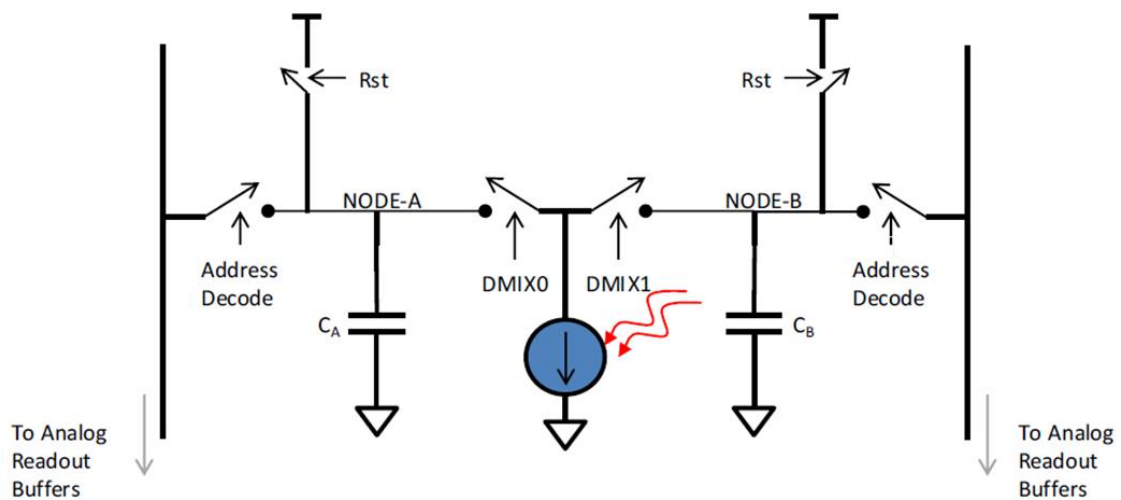

Figure 5: A simplified time-of-flight pixel (halved, so this is tap A or B).

6. Time-of-flight performance parameters

There are multiple parameters influencing the performance of a ToF sensor, some of them are sensor dependent (see also the glossary in Section 2):

- The responsivity of the pixels i.e. the capacity of the pixels to transform light into an electrical signal. The higher the better.
- Their demodulation contrast which is the capacity to measure the phase shift of the incident light with respect to the modulation signal. The closer to 1 the better.
- The integration capacitance (full-well capacity) of the pixel. This defines the amount of charges the pixel can hold before being saturated. The higher it is the more we'll be able to reject sunlight.
- The dark noise level, which is mainly important at low light level. The lower this parameter, the lower the distance noise.

Others are related to the application:

- The amount of optical illumination power during an exposure. The maximum is typically limited by eye-safety constraints, or cost and size of the module.
- The modulation frequency of the illumination, high modulation frequency results in high distance precision but low unambiguous range.
- The optical transmission to the pixels indicating the amount of light getting from the environment to the sensor, the higher the better.

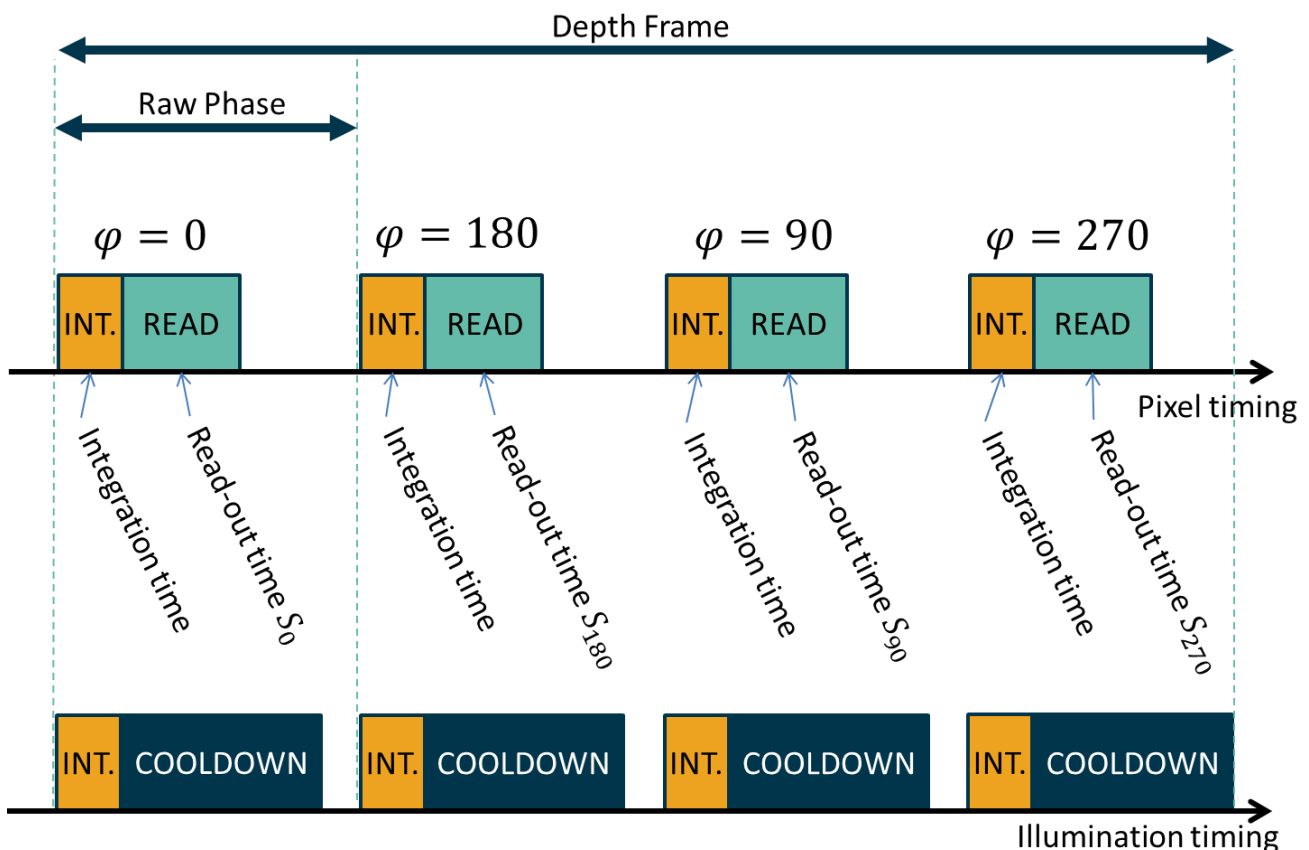

Figure 7: Time-of-flight four phase sequence.

- The integration time. Higher values will get better distance images but at the cost of more power consumption in the sensor and the illumination and lower frame rate.
- The cooldown time relative to the illumination used and the power parameters, impacting the average power emission and consumption
- The readout time depends on the number of pixels on the sensor and the sampling rate of the ADCs, the lower, the faster the image can be processed and the higher the framerate can be.

7. Time-of-flight optical parameters

The illumination to create the modulated light signal required for TOF distance measurements is generally coming from an LED or a VCSEL operating in the near-infrared range, this wavelength range is chosen to make this light invisible to the human eye.

The sensor is also sensitive to the ambient light and not only the reflected light coming from the modulated light source. Any detected light generates photon shot noise, so a high ambient light value will lower the signal to noise ratio (SNR) as the reflected modulated light is the only one to carry distance information.

In order to gather light reflected from the scene that the sensor is facing it's important to have a lens. This will determine the FOV of the sensor and also the amount of modulated light that this lens will gather on the sensor to create the depth image. The "faster" the lens i.e. the larger the aperture of the lens or the lower the f-number ($f/\#$), the better the SNR can be.

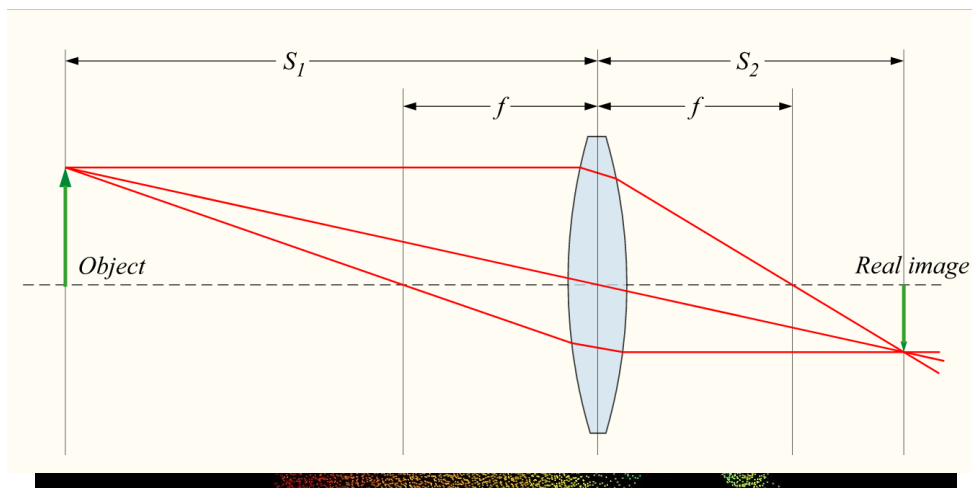

Figure 8 : Optics basic rules. Here, if the diameter of the lens is D , then the F-Number is f/D and determines brightness. (The lower the better)

Because of the imaging lens, every pixel coordinate (x_i, y_i) will correspond to a certain angle in the lens FOV. With this information we will be able to create some 3D point cloud images using the depth images.

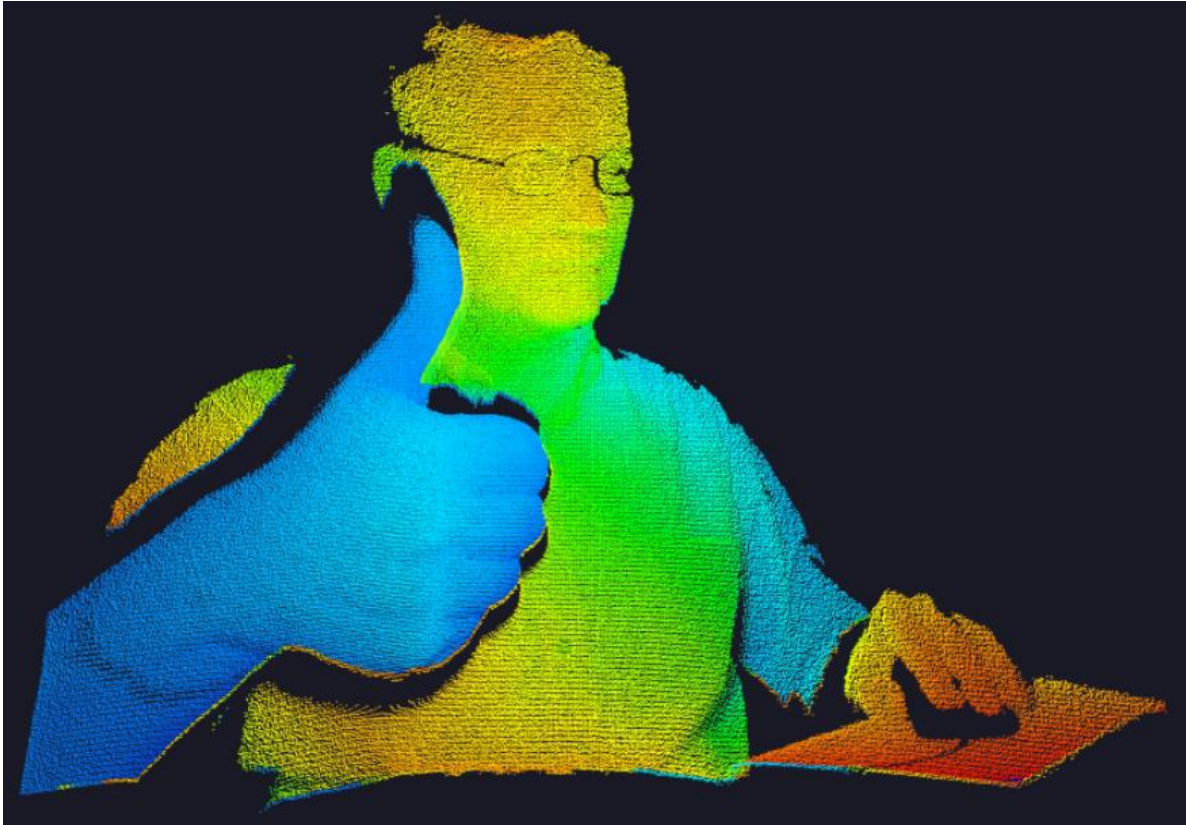

Figure 9 : A 3D point cloud image created using the distance data from an EVK75027 and lens calibration.

8. Unambiguous range and aliasing

Because of the modulated nature of the light used for illuminating the scene when using a ToF system an unambiguous range is defined depending on the modulation frequency used. If the light travels back and forth during a longer period of time than the period of the modulated light, then the distance calculations will be wrong as we won't be able to make a difference between a signal coming back from a far distance and another signal coming back from a close distance with the same phase shift.

The unambiguous range is the one way distance and equals half of the maximum distance the light can reach during a period.

For example, at 20 MHz:

$$distance_{unambiguous} = \frac{\lambda_{mod}}{2} = \frac{c}{2f_{mod}} = 7,5 \text{ m}$$

Where λ_{mod} represents the wavelength of the modulated light signal and c is the speed of light.

This will result in a phenomenon called "aliasing". The distance measurements will be repeated with a period equal to the unambiguous range when the real distance is increasing.

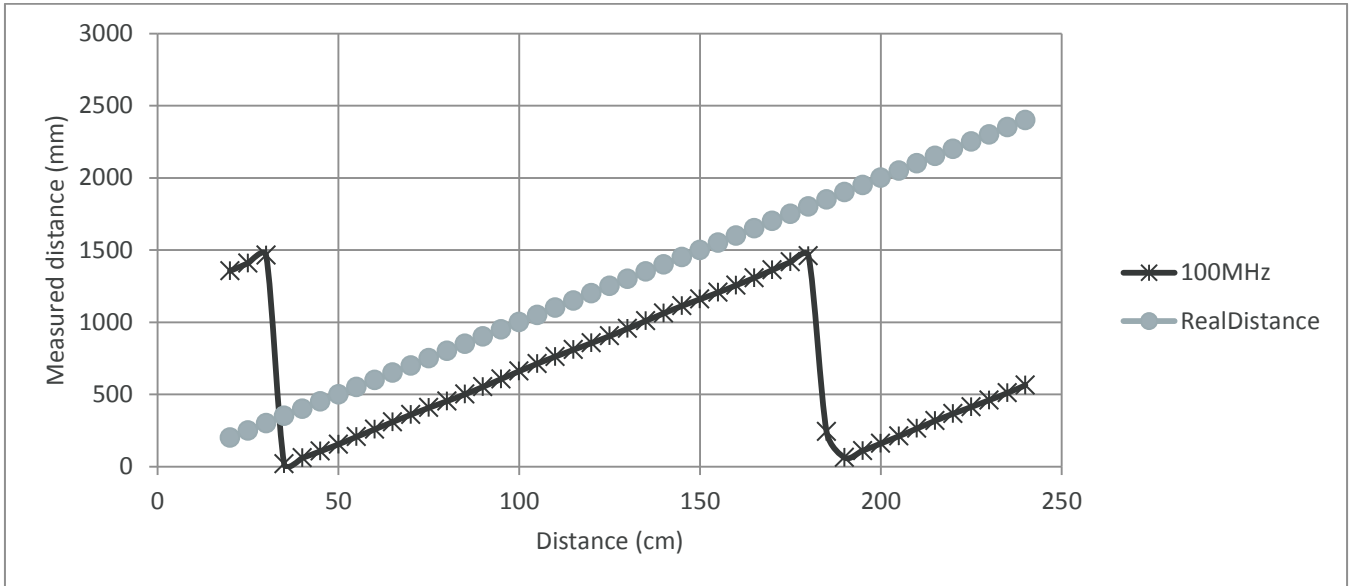

Figure 10: Aliasing effect visible when measuring distances at 100MHz with the EVK75027. We can see the 1.5 meters periodicity of the distance measurements.

9. Distance offset

The distance calculated using a ToF camera will be proportional to the real distance, but often if not calibrated there will be a constant distance offset between the real distance and the measured distance using the camera. That is visible on Figure 10 as the measurements at the origin aren't starting at 0 meters. This distance offset depends on many parameters of the camera and will be different depending on the parameters used. On the EVK75027 for example, for each modulation frequency, the distance offset will be different:

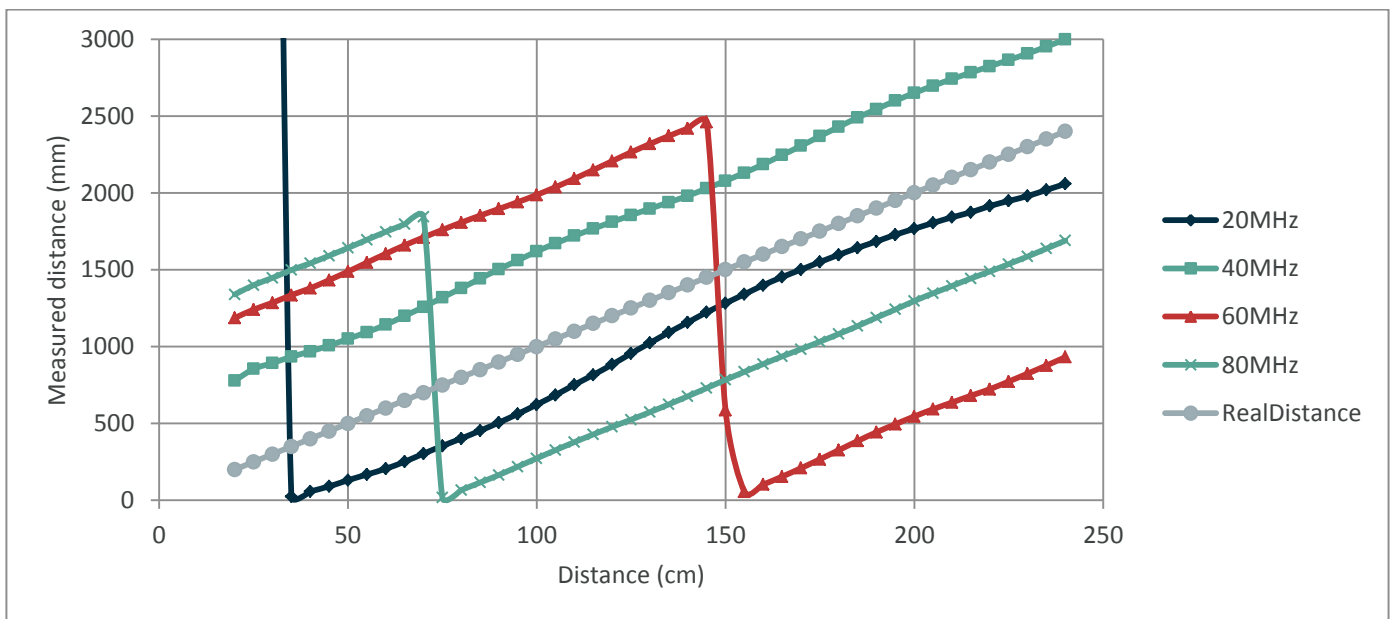

Figure 11: Linearity measurements at different modulation frequencies using the EVK75027. The difference in the distance offsets can be seen here.

In order to remove this offset, add a fixed value to the distance data by setting the correct distance offset value on the EVK75027:

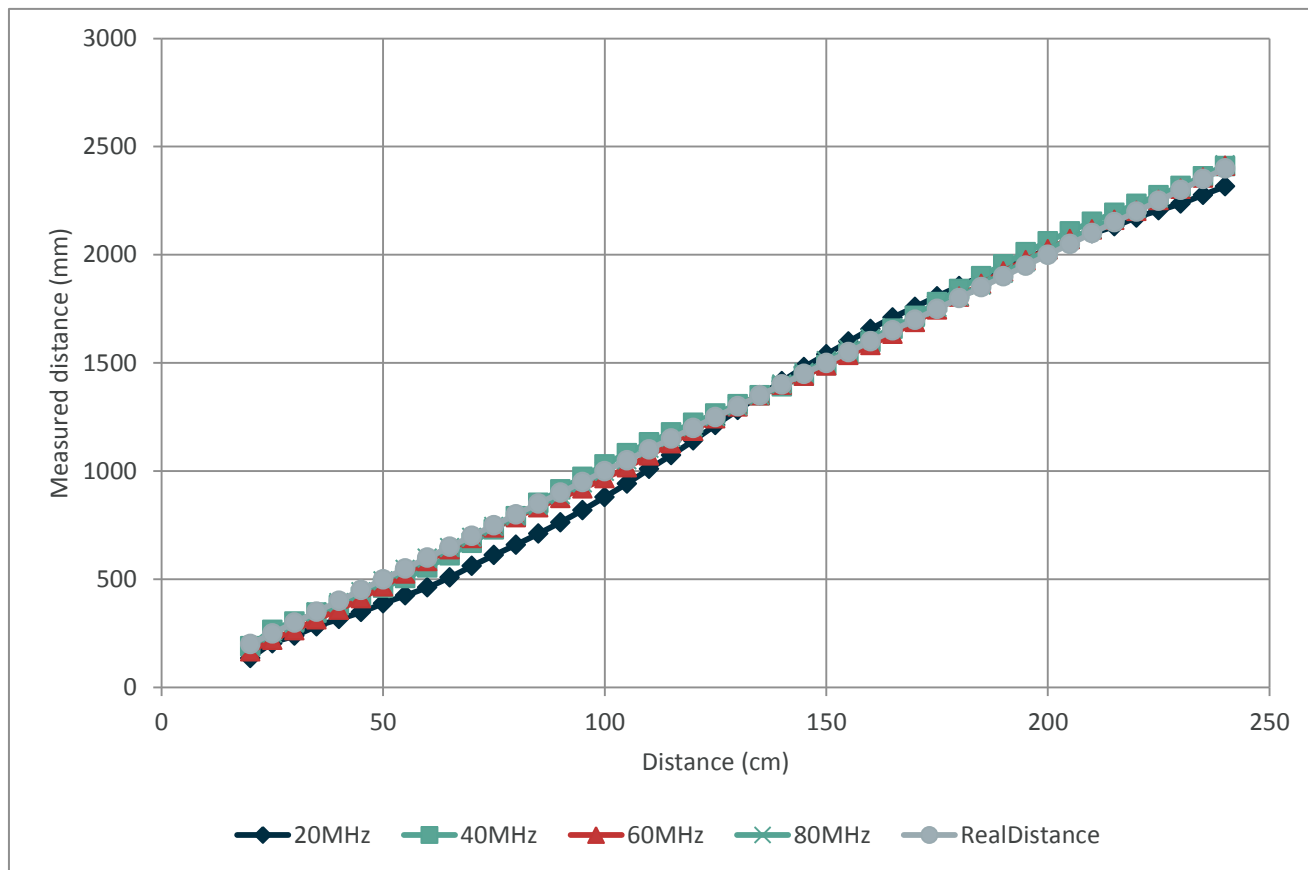

Figure 12: Linearity measurements after offset calibration.

10. Performance comparison between time-of-flight, stereo vision and structured light

Best

Worst

Parameter	Stereo vision	Structured light	Time-of-flight
Range	Limited	Can be adapted	Can be adapted
Cost	Low	High	Medium
Software complexity	High	Medium	Low
Depth accuracy	Low	High	Medium
Low-light performance	Weak	Good	Good
Sunlight robustness	Good	Weak	Good
Size	Increases with range	Increases with range	Compact
Field-of-view	Typ. < 90 deg	Typ. < 90 deg	Can be adapted

*Table 1 : Performance comparison between different 3D sensing technologies.
Inspired from: Larry Li – Time-of-Flight Camera – An Introduction – Texas Instruments*

Each of these 3D imaging technologies have their own technical limitations:

- For stereovision the main limitations are the difficulty to measure 3D coordinates with uniform surfaces and also the cost of processing of the images which requires a lot of fast computation.
- For structured light the problems came from the low sunlight robustness or the low spatial resolution as the performance is closely related to the performance of the illumination pattern projected and high resolution and important sunlight robustness requires high power.
- Eventually for time of flight the limitations will be related to the range and especially for the unambiguous distance and also the optical power required which can be really important depending on the required distance precision.

11. Melexis ToF Evaluation Kits

Melexis Evaluation Kits (EVK) are a complete ToF camera and can be directly connected to a PC for visualization and recording of depth map data while allowing direct access to many configuration settings.

Feature	EVK Part number	FOV (Horizontal)	Wavelength	Illumination
Gen3 VGA	EVK75027-110-940-2	110°	940 nm	2 VCSELs – Automotive
Gen3 QVGA	EVK75026-110-940-2	110°	940 nm	2 VCSELs – Automotive

EVK Customer Documentation Package will include:

- Webviz visualizer using any web browser.
- CAPI, Matlab & Python SDK (+ example codes)
- Modular architecture (incl. 3D .step files)
- HW description (schematics & layout)
- Manuals
- Eye-safety certificate



Figure 13: EVK75027-110-940-2